

Sinexcel Ultra Static Var Generator (SVG) **--USER MANUAL**

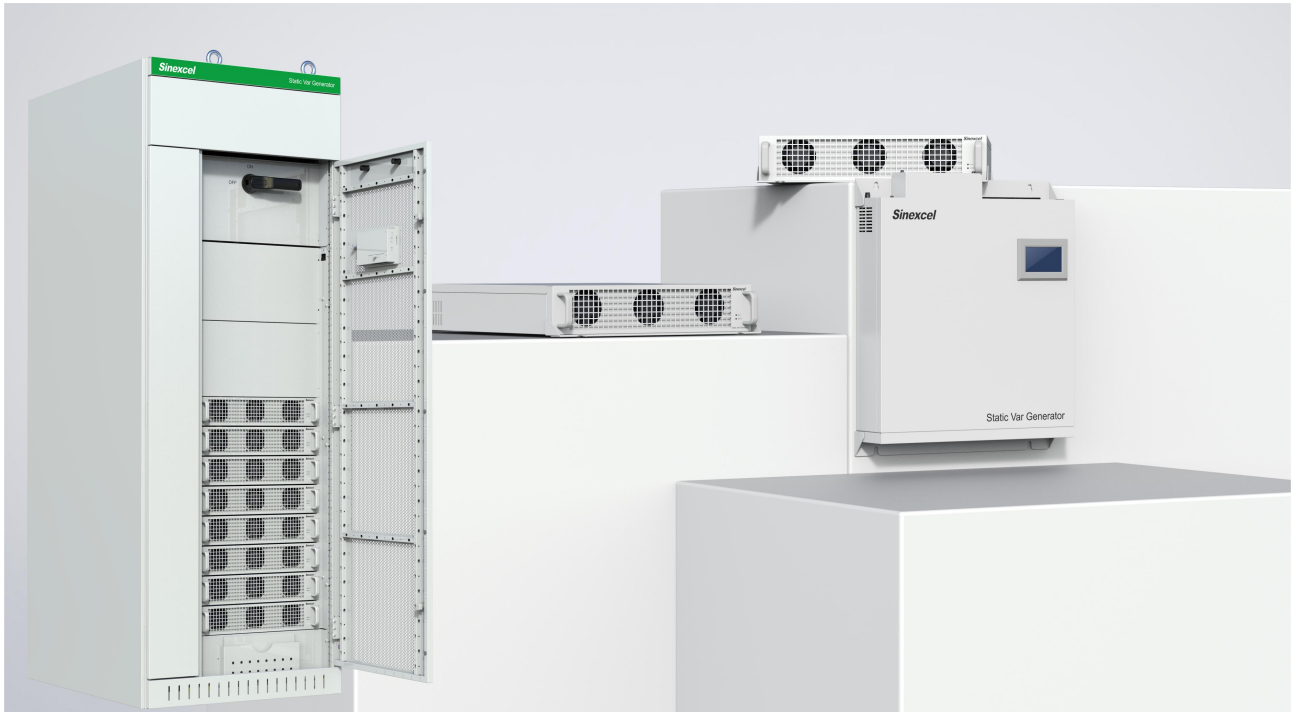



Sinexcel Electric Co., Ltd





SAFETY INSTRUCTIONS



Thank you for choosing Sinexcel Ultra Static Var Generator (SVG) module. Please read the safety instructions carefully before using and ensure that the unit is operated according to the instructions in this manual. The safety instructions contain important information, which ensure that you can safely and properly use the product and prevent personal injury or property damage. Please keep this manual accessible near the unit so that users can easily reference this information.

This manual uses the following illustrations and symbols to highlight important safety information. Please ensure that you are very familiar with these procedures and follow these instructions carefully.



	<p>DANGER</p> <p>Failure to comply with the instructions or improper operation may cause serious electric injury and can be fatal.</p>
	<p>WARNING</p> <p>Failure to comply with the instructions or improper operation may cause wound.</p>
	<p>CAUTION</p> <p>Failure to comply with the instructions or improper operation may cause personal injury and damage to the equipment.</p>

SAFETY PRECAUTIONS

	<p>DANGER</p> <p>Do not expose it to where rain or moisture is heavy, and keep it away from combustible liquid, gas or explosive.</p>
	<p>DANGER</p> <p>To avoid high voltage risks, the discharge time of DC capacitors should be above 15 minutes. Make sure the operation is performed after full discharge.</p>
	<p>WARNING</p> <p>Installation must be done by well-trained and qualified personnel in a controllable environment.</p>
	<p>WARNING</p> <p>Any maintenance work must be carried out by qualified technical personnel; all power must be cut off before maintenance.</p>





	CAUTION Reserve enough space around the equipment, so as to maintain good ventilation and easy maintenance access and operation.
	CAUTION Read the user manual carefully before connecting the power, and keep it easily accessible for future reference.

WIRING PRECAUTIONS





	WARNING This equipment has a leakage current from 3.5mA to 1000mA. Before connecting the power supply, the user must make sure the equipment is properly grounded. When choosing RCCB or RCD equipment, the leakage current of the module should be considered. The RCCB chosen should not be sensitive to the unidirectional DC pulse (Class A) and the transient pulse. Please note that the leakage current of the load will also flow through RCCB or RCD; the grounding of the device must meet the local electrical regulations
	WARNING Compensation capacity and current-carrying capacity must be taken into full consideration for wiring.
	CAUTION The cables connected to the power terminals must be connected to a circuit breaker or other protective devices and the capacity of protective devices should match the capacity of Static Var Generator.







PRECAUTIONS FOR USE

	CAUTION The SVG is used to improve power factor. The capacity of SVG should be selected in accordance with reactive power.
---	--

	<p>CAUTION</p> <p>The SVG must be used with external current transformers.</p>
	<p>CAUTION</p> <p>To ensure SVG has good reliability and to avoid overheating, do not block or cover the air inlet/outlet.</p>
	<p>CAUTION</p> <p>No corrosive gas and conductive dust is allowed in the working environment.</p>
	<p>CAUTION</p> <p>The working temperature should be -10°C and 40°C. SVG may derate if beyond this range;</p>

STORAGE PRECAUTIONS

	<p>CAUTION</p> <p>Seal SVG with its original packing materials in case of damage caused by rat invasion.</p>
	<p>CAUTION</p> <p>If immediate installation is not required, make sure to store the equipment in dry and well-ventilated indoor environment, the storage temperature should be $-40^{\circ}\text{C}\sim 70^{\circ}\text{C}$, and relative humidity should be 5%~95%.</p>
	<p>CAUTION</p> <p>Improper storage conditions, such as humidity, will cause moisture and mildew on PCB and other components; halogen gas will corrode electrolytic capacitors; sulfur-containing gas will corrode copper and other semiconductors and resistance components;</p>
	<p>CAUTION</p> <p>If the module is not used for a long time (> 3 months), it should not be opened (sealed bag), or should be resealed with a sealed bag after opening; the temperature for long-term storage should not exceed 40 degrees.</p>

	<p>CAUTION</p> <p>After 1-3 years of storage in a sealed environment with a temperature not exceeding 40 degrees, the first time you turn on the power without turning it on, keep it for more than 1 hour to activate the internal electrolytic capacitor.</p>
	<p>CAUTION</p> <p>If the module is not sealed, depending on the harsh environment (humidity, temperature, halogen, sulfur, ammonia, salt spray), basically more than 3 to 6 months, the internal components of the module have been corroded or mildewed or damp, the module is powered on. The risk of frying the machine is very high;</p> <p><u><i>Note: the module itself cannot work in halogen, sulfur, ammonia, and heavy salt spray environments, such as seaside, chemical plants, conductive dust, and etc..</i></u></p>
	<p>CAUTION</p> <p>Normal temperature (such as normal indoor environment, temperature < 40 degrees, humidity < 70%), more than 6 months to 1 year, according to the first power-on method;</p>
	<p>CAUTION</p> <p>High temperature, humidity is not too high (40~70 degrees, such as arid desert areas), PCB is not moldy, etc. After more than 3 months, it will be handled as if it is powered on for the first time and not turned on;</p>
	<p>CAUTION</p> <p>The humidity is high for a short period of time (1~2 weeks), check that there is no mildew, and it can be dried.</p>
	<p>CAUTION</p> <p>In other cases, the risk of bombing in unsealed storage is high, and there are currently no remedial measures.</p>

PRODUCT IDENTIFICATION

When users receive Sinexcel products, which can obtain basic information about the product through the nameplate. The nameplate is a label that is affixed to the product and contains important information such as the model number, serial number, and manufacturing date. This information can be used to identify the product and track its testing and package history. In addition, the nameplate also include information about the product's specifications, such as its voltage, current, and power rating. This information can be useful for customers who need to know the product's capabilities and limitations.

Sinexcel nameplate of module is divided into two parts.

The top part displays the product name, voltage, wiring, capacity, size, weight, protection level, and product serial number. The black mark represents the product shipment selection, and customers can know the production date of the module and the production order of the same batch through the serial number.

The bottom part displays the product certification and company address. The nameplate is the latest shipping nameplate from Sinexcel and will take effect from July 2023.

Sinexcel nameplate of cabinet is divided into two parts.

The top part displays the product name, input, output, voltage, wiring, capacity, size, weight, protection level, and product serial number. The black mark represents the product shipment selection, and customers can know the production date of the module and the production order of the same batch through the serial number.

The bottom part displays the product certification and company address. The nameplate is the latest shipping nameplate.

Sinexcel	CE
Name: Ultra Static Var Generator Model: ■SVG 100 Ultra 44L/HL Voltage: 400Vac 50/60Hz Wiring System: ■3P4W □3P3W Capacity: □30K □50K ■100K Dimension: D100*W500*H520mm Weight: 31kg IP Class: IP20 SN: SH0P20025611YYMMDD000X	
Manufacturer: Sinexcel Electric CO., Ltd Address: 6th Building, 2nd District, Baiwengxin High-tech Industry Park, Songbai Road, Nanshan District, Shenzhen	
	

Figure 1 The Nameplate of Module

Sinexcel	CE
Model: SVG 400V/400k FM Input: 400Vac 0~600A 50/60Hz 3P4W Output: 400Vac 0~600A 50/60Hz 3P4W Parc,r: 0~400kvar Size,Weight: W600×D1000×H2200, 400kg IP Class: IP20 SN: SH0P20025611YYMMDD000X	
Shenzhen Sinexcel Electric Co.,Ltd	
	

Figure 2 The Nameplate of Cabinet

Note: The Serial Number (SN) is the ID of the module. The serial number reveals the part number and the manufacturing date. The last 4 numbers it indicate the number of the module produced.

For example: The number "0010" indicates that this is the 10th module which has this same part number produced on that day.

For the module with other type certification that the nameplate will show it in the top right-hand corner indicating the certification.

Sinexcel reserves the right to update nameplates. This means that Sinexcel has the authority to make changes to the nameplates on their products, which may include updating information such as the model number, serial number, or other identifying information.

Sinexcel has launched a simplified product naming system to streamline the ordering process for customers due to the wide variety of products they offer.

For example: Sinexcel SVG Ultra 100K 4L HL represents the Sinexcel Ultra SVG series, with a module capacity of 100K. It is suitable for use in 400V three-phase four-wire low-voltage systems. The module is a wall-mounted type with a 4.3-inch Human-Machine Interface screen.

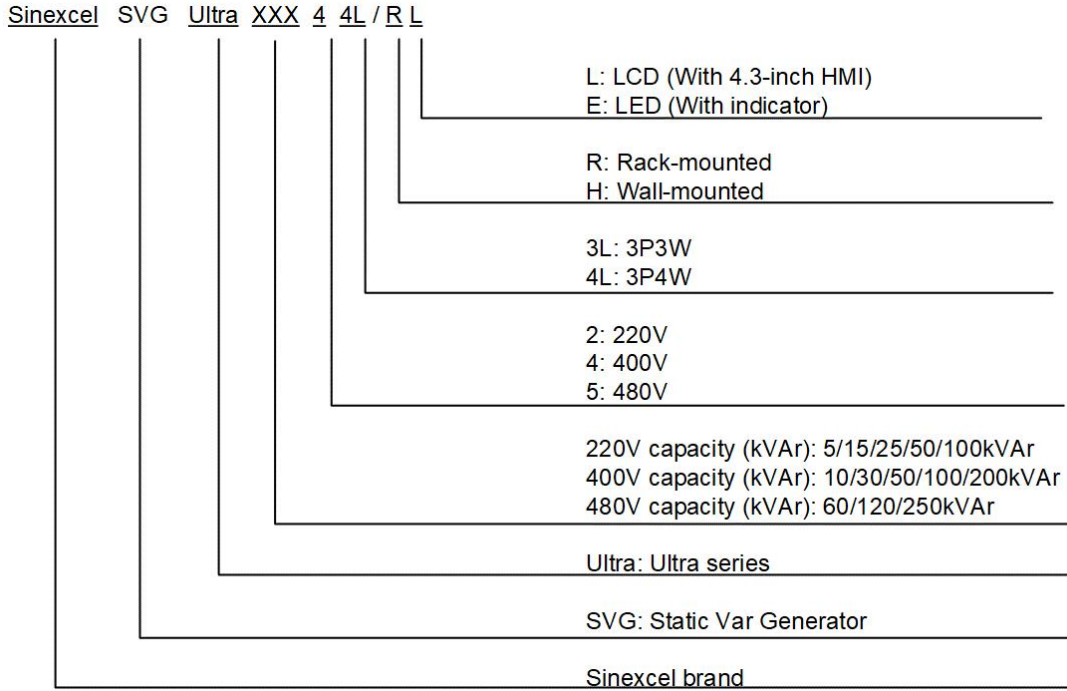

Figure 3 Product Naming Introduction

The detailed Sinexcel available product list please check the table below:

Table 1 Available Sinexcel Ultra SVG

	System Wiring	Installation Type	Nominal Voltage	Certification
15kVAr	3P3W / 3P4W	Wall mounted with LCD	220V	CE
25kVAr				
50kVAr		Rack mounted with LED		
100kVAr				

30kVAr	3P3W / 3P4W	Wall mounted with LCD Rack mounted with LED	400V	CE
50kVAr				
100kVAr				
200kVAr				

Note: The table is showed the Sinexcel standard SVG module, which customer can order from March 2023.

DOCUMENT REVISION

Revision	Date	Revised Content
V1	2023/09/06	Integrate user manual information
V2	2023/11/01	Revised detailed information
V2.1	2024/01/10	Revised detailed information
V2.2	2024/01/12	Revised cabinet ventilation calculation
V2.3	2024/05/23	Revised the power cable selection
V2.4	2024/06/20	Revised the IP54 cabinet build

Sinexcel reserves the right to make modification to the device or the unit specifications set out in the user manual without prior notice.

CONTENT

SAFETY INSTRUCTIONS	II
SAFETY PRECAUTIONS	II
WIRING PRECAUTIONS	III
PRECAUTIONS FOR USE	III
STORAGE PRECAUTIONS	IV
PRODUCT IDENTIFICATION	VI
DOCUMENT REVISION	VIII
CHAPER I PRODUCT DESCRIPTION	1
<i>1.1 PRODUCT INTRODUCTION</i>	<i>1</i>
<i>1.2 PRODUCT FEATURES</i>	<i>1</i>
<i>1.3 WORKING PRINCIPLE</i>	<i>1</i>
<i>1.4 PRODUCT DETAILS</i>	<i>2</i>
<i>1.4.1 PRODUCT DRAWINGS_ 220V CE SVG MODULE</i>	<i>2</i>
<i>1.4.1 PRODUCT DRAWINGS_ 400V CE SVG MODULE</i>	<i>4</i>
<i>1.4.3 WIRING TERMINAL</i>	<i>6</i>
<i>1.4.3 CABINET SOLUTION</i>	<i>8</i>
CHAPTER II INSTALLATION AND WIRING	14
<i>2.1 PRE-INSTALLATION NOTICE</i>	<i>14</i>
<i>2.2 ENVIRONMENT REQUIREMENTS</i>	<i>14</i>
<i>2.3 INSTALLATION</i>	<i>16</i>
<i>2.3.1 WALL-MOUNTED</i>	<i>17</i>
<i>2.3.2 RACK-MOUNTED</i>	<i>18</i>
<i>2.3.3 CABINET</i>	<i>19</i>
<i>2.3.4 TOP-VENT CABINE</i>	<i>20</i>
<i>2.3.5 IP54 CABINET</i>	<i>21</i>
<i>2.4 CONNECTION</i>	<i>22</i>
<i>2.4.1 SINGLE WALL MOUNTED</i>	<i>22</i>
<i>2.4.2 MULTIPLE WALL MOUNTED</i>	<i>23</i>
<i>2.4.3 SINGLE RACK MOUNTED</i>	<i>25</i>
<i>2.4.4 MULTIPLE RACK MOUNTED</i>	<i>26</i>
<i>2.4.5 CABINET</i>	<i>28</i>

2.5 CABLE	30
2.5.1 POWER CABLE	30
2.5.2 COMMUNICATION CONNECTION	35
2.5.3 485 COMMUNICATION CABLE	35
2.5.4 CAN COMMUNICATION CABLE	36
2.5.5 DIP SWITCH	36
CHAPTER III COMMISSIONING	38
3.1 4.3-INCH HMI INTRODUCTION	38
3.1.1 DATA INTERFACE	39
3.1.2 PARAMETER SETTING INTRODUCTION	43
3.1.3 RECORD INTRODUCTIONS	46
3.2 Commissioning step with 4.3-inch HMI	47
3.2.1 DC BUS VOLTAGE CHECK INTRODUCTION	47
3.2.2 CHECK WHETHER THE DATA IN THE HMI IS MATCHING EXTERNAL METER.	48
3.2.3 PARAMETER SETTING	49
3.2 7-INCH HMI INTRODUCTION	50
3.2.1 'INFO' ILLUSTRATE	51
3.2.2 RECORD INTRODUCTION	53
3.2.3 PARAMETER SETTING INTRODUCTION	54
3.2.4 PARAMETER SETTING	58
3.2.5 HELP	59
3.2.6 ABOUT	59
APPENDIX I SINEXCEL ULTRA SVG SPECIFICATION	60
APPENDIX II HUMAN-MACHINE INTERFACE	61
7-INCH INTERFACE & DIMENSIONS	61
SINEXCEL 7-INCH HMI RECORDING AND DOWNLOAD FUNCTION	62
SINEXCEL HMI HOLIDAY FUNCTION	67
SINEXCEL 7-INCH HMI HIGHER LEVEL PASSWORD PARAMETER INTRODUCTION	68
SINEXCEL 4.3-INCH HMI HIGHER LEVEL PASSWORD PARAMETER INTRODUCTION	73
SINEXCEL 7-INCH HMI SOFTWARE UPGRADE INSTRUCTION	77
SINEXCEL 4.3-INCH HMI SOFTWARE UPGRADE INSTRUCTION	81
SINEXCEL FACTORY CALIBRATION FOR SVG MODULE	89
APPENDIX III DRY CONTACT BOARD INTRODUCTION	95
INTERFACE & DIMENSIONS	95
RJ45 ETHERNET PORT	96

OUTPUT DRY CONTACT 2	96
OUTPUT DRY CONTACT 1	97
INPUT DRY CONTACT	98
DRY CONTACT BOARD INSTALL POSITION	99
DRY CONTACT BOARD CONNECTION GUIDANCE	100
CONNECT TO SINGLE LCD MODULE	100
CONNECT TO 7-INCH HMI	101
APPENDIX IV MODBUS	102
<i>MODBUS PROTOCOL OUTLINE</i>	<i>102</i>
<i>DATA TYPE</i>	<i>102</i>
<i>COMMUNICATION</i>	<i>103</i>
<i>APPLICATION LAYER PACKET/FRAME FORMAT DEFINITION</i>	<i>103</i>
<i>REQUEST/RESPONSE INFORMATION DETAILS</i>	<i>105</i>
<i>ACQUIRE STATUS INFORMATION AND ALARMING INFORMATION OF THE DEVICE</i>	<i>105</i>
<i>ACQUIRE ANALOG DATA</i>	<i>107</i>
<i>READ THE WAVEFORM DATA OF THE DEVICE(WAVEFORM)</i>	<i>109</i>
<i>READ THE WAVEFORM DATA OF THE DEVICE (HISTOGRAM)</i>	<i>109</i>
<i>ACQUIRE INFORMATION OF MANUFACTURER</i>	<i>110</i>
<i>READ INFORMATION OF MONITOR MANUFACTURER</i>	<i>110</i>
<i>ACQUIRE PARAMETERS OF DEVICE (GENERAL SETTINGS)</i>	<i>111</i>
<i>ACQUIRE PARAMETERS OF DEVICE (PARAMETER OF PHASE ANGLE OFFSET)</i>	<i>113</i>
<i>ACQUIRE PARAMETERS OF DEVICE (HARMONIC COMPENSATION PARAMETERS)</i>	<i>116</i>
<i>ACQUIRE PARAMETERS OF DEVICE (NO INITIALIZATION)</i>	<i>118</i>
<i>READ THE PARAMETERS OF THE DEVICE (EACH HARMONIC COMPENSATION MODE)</i>	<i>118</i>
<i>SETTING PARAMETERS OF DEVICE</i>	<i>118</i>
<i>ACQUIRE FAULT RECORD</i>	<i>119</i>
<i>SINEXCEL MODBUS APPLICATION</i>	<i>120</i>
<i>MODBUS TCP/IP</i>	<i>120</i>
<i>MODBUS RTU</i>	<i>121</i>
APPENDIX IV ICMS-P2 INTERGRATED CONTROL MONITORING SYSTEM	123
INTERFACE & DIMENSIONS	123
ICMS-P2 INTRODUCTION	124
SERVICE ENVIRONMENT	124
ICMS-P2 DEFINITION	125
ICMS-P2 FUNCTION	125
ICMS-P2 TECHNICAL PARAMETERS	127
BASIC PARAMETERS	127
MEASUREMENT ACCURACY	127
CONTROL AND PROTECTION PARAMETER RANGE	128

<i>EXTERNAL COMMUNICATION INTERFACE</i>	128
APPENDIX VII CABINET DESIGNING INSTRUCTIONS	129
CABINET COMPONENT LIST	129
CABINET VENTILATION DESIGN	129
APPENDIX VIII CURRENT TRANSFORMER	132
<i>CT TYPE</i>	132
<i>CT CABLE</i>	132
<i>CT CONNECTION ON SECONDARY SIDE</i>	132
<i>CT SIZING</i>	132
<i>CT VA Burden</i>	133
<i>INSTRUCTION</i>	133
<i>MECHANICAL STRUCTURE</i>	133
<i>CT RATIO</i>	133
<i>CT BURDEN</i>	133
<i>CT CABLE</i>	133
<i>CONCLUSION</i>	134
<i>CALCULATION</i>	134
<i>THE VA BURDEN OF OUR SVG MODULE</i>	134
<i>CT SPECIAL APPLICATION INSTALLATION</i>	134
APPENDIX VIII CABLE SIZING	135
APPENDIX IX System power on and shutdown	136
<i>POWER ON STEPS</i>	136
<i>POWER OFF STEPS</i>	136
<i>AUTO POWER ON</i>	136
<i>EMERGENCY STOP</i>	136
APPENDIX XI Sinexcel COMMON FAULT DIAGNOSIS	137

CHAPTER I PRODUCT DESCRIPTION

1.1 PRODUCT INTRODUCTION

Sinexcel Ultra SVG supports to compensating reactive power, and three-phase unbalancing.

1.1.1 POWER FACTOR CORRECTION

Static Var Generator with power factor correction function are designed to improve power factor in electrical systems. Power factor is a measure of how efficiently electrical power is being utilized. A low power factor can result in increased energy losses, reduced system efficiency, and addition costs.

Static Var Generator with power factor compensation work by actively detecting the power factor and injecting or absorbing reactive power as needed to bring the power factor closer to unity (1.0). By doing so, they help avoid user avoid the penalty, optimize power usage, reduce energy wastage, and enhance system performance.

1.2 PRODUCT FEATURES

Modular Design: Sinexcel SVG has a modular design, allowing easy installation and future expansion. Additional modules can be added to become a bigger compensation system.

High Adaptability: Suitable for the site with poor and unstable power supply, wide operation voltage range, operation voltage upper limit is up to 456V, and lower limit is 228V (For 400V module).

High Accuracy: Sinexcel SVG Ultra has a high level of accuracy, with a compensation rate of up to 99%,

User-friendly Interface: Sinexcel SVG Ultra features a user-friendly interface that allows users to easily set parameters and monitor the performance of the system.

Compact Size: Sinexcel SVG Ultra's extreme compact size allows for easy installation and saves on valuable space in electrical rooms.

1.3 WORKING PRINCIPLE

Sinexcel Ultra Static Var Generator is a device that is used to eliminate reactive power generated in electrical systems.

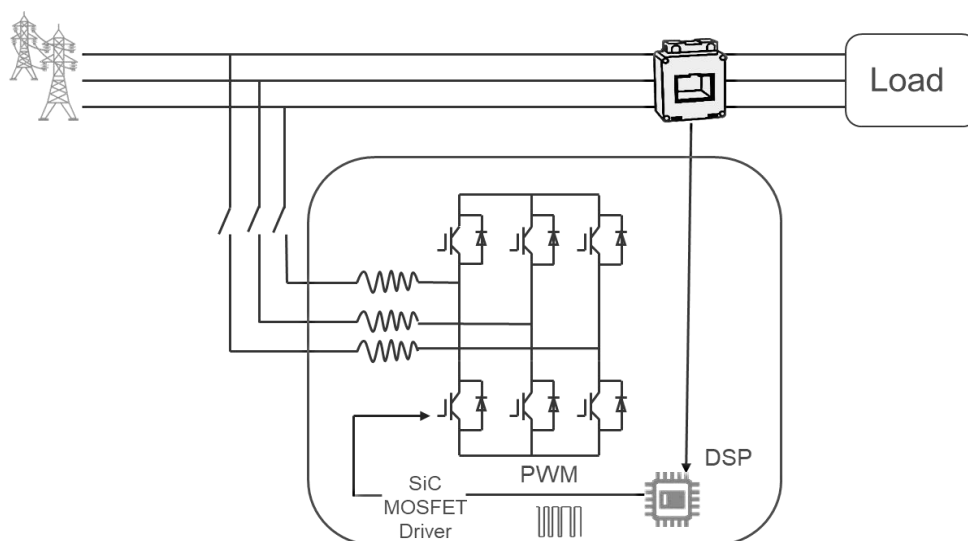

Figure 1- 1 Sinexcel Ultra SVG operation principle

The working principle of Sinexcel Ultra SVG involves the use of an external Current Transformer (CT) to detect the load current. The detected current will be processed by a Digital Signal Processor (DSP), which identifies whether the load current has any reactive power components or not.

If reactive power is detected, the DSP calculates the reactive content and sends a signal to the SiC Mosfet to generate compensating current. The compensating current has the same magnitude as the reactive power current but in the opposite direction, thereby canceling out the reactive power. This process helps to improve the power factor in the system and the efficiency of the electrical system.

Sinexcel Ultra SVG works by using advanced signal processing techniques to identify and eliminate reactive power in electrical systems, which helps to ensure the smooth operation of electrical equipment and improves the overall efficiency of electrical systems.

1.4 PRODUCT DETAILS

1.4.1 PRODUCT DRAWINGS__220V CE SVG MODULE

Sinexcel Static Var Generator is divided into two types according to installation method. One is wall mounted type, which can be hung on the wall. The other is rack mounted type and can be installed in the cabinet. Please consult Sinexcel product engineer for details of cabinet.

Please refer to Fig. 1-2 for the appearance and size of Ultra CE 220V 15kVAR wall-mounted type.

Please refer to Fig. 1-3 for the appearance and size of Ultra CE 220V 15kVAR rack-mounted type.

Please refer to Fig. 1-4 for the appearance and size of Ultra CE 220V 25kVAR wall-mounted type.

Please refer to Fig. 1-5 for the appearance and size of Ultra CE 220V 25kVAR rack-mounted type.

Please refer to Fig. 1-6 for the appearance and size of Ultra CE 220V 50kVAR wall-mounted type.

Please refer to Fig. 1-7 for the appearance and size of Ultra CE 220V 50kVAR rack-mounted type.

Please refer to Fig. 1-8 for the appearance and size of Ultra CE 220V 100kVAR wall-mounted type.

Please refer to Fig. 1-9 for the appearance and size of Ultra CE 220V 100kVAR rack-mounted type.

Note: Sinexcel Ultra series, the standard wall mounted is with LCD, the standard rack mounted is with LED. If needs other type module, please discuss with Sinexcel's engineer.

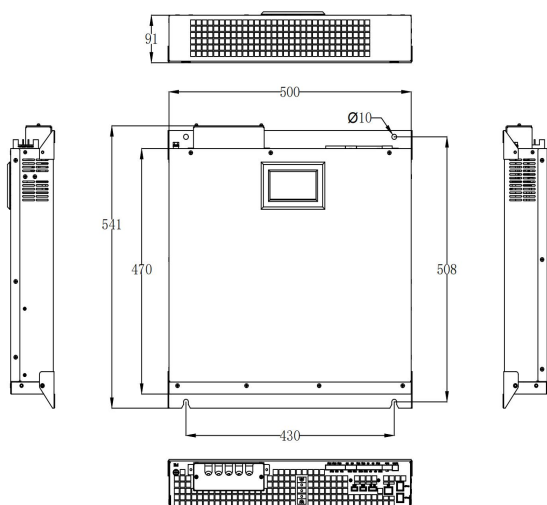

Figure 1- 2 Sinexcel Ultra CE 220V 15kVAR wall-mounted

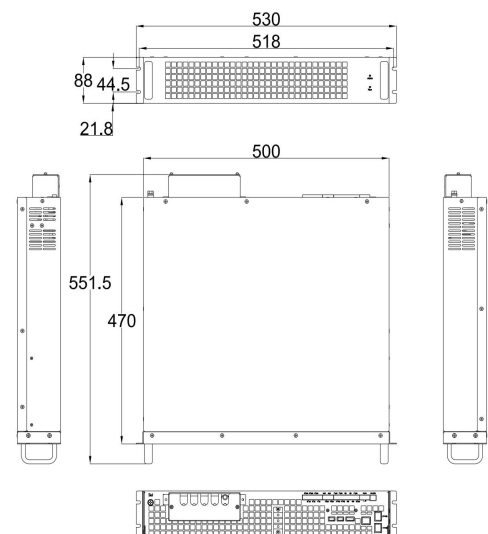

Figure 1- 3 Sinexcel Ultra CE 220V 15kVAR rack-mounted

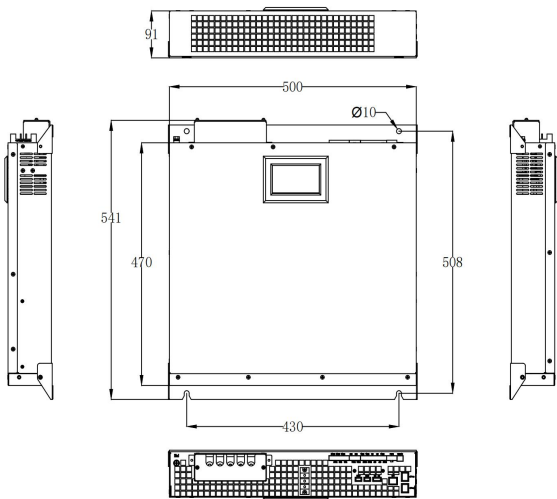

Figure 1- 4 Sinexcel Ultra CE 220V 25kVAr wall-mounted

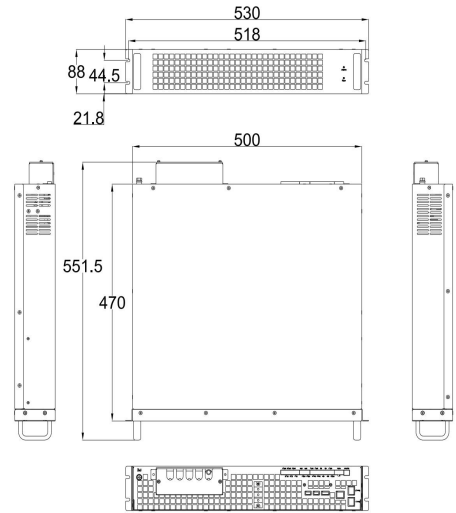

Figure 1- 5 Sinexcel Ultra CE 220V 25kVAr rack-mounted

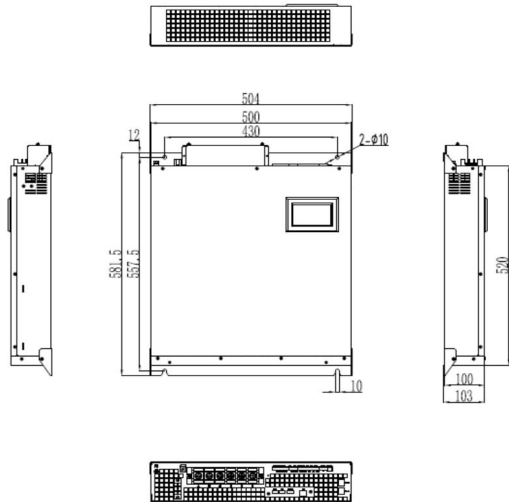

Figure 1- 6 Sinexcel Ultra 50kVAr SVG wall-mounted

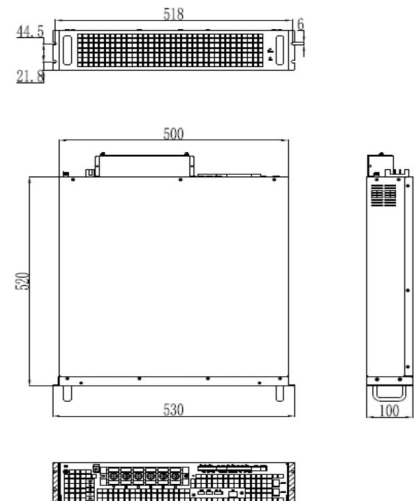

Figure 1- 7 Sinexcel Ultra 50kVAr SVG rack-mounted

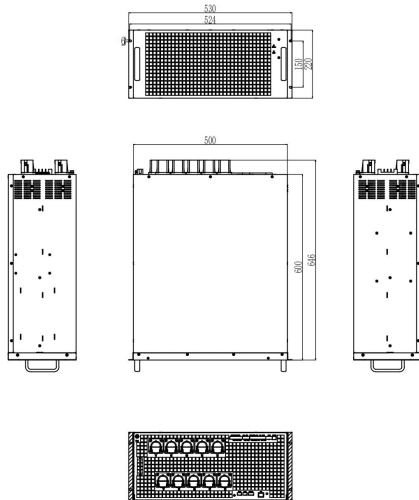

Figure 1- 8 Sinexcel Ultra CE 220V 100kVAr wall-mounted

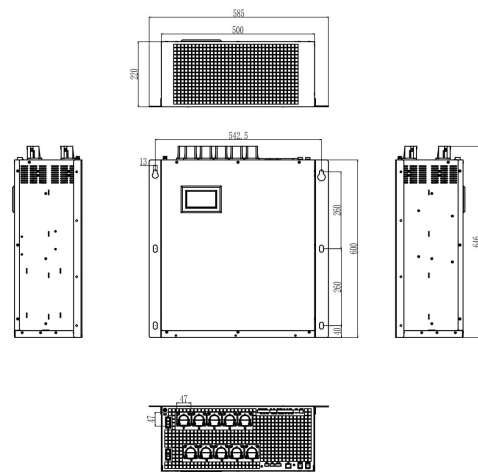

Figure 1- 9 Sinexcel Ultra CE 220V 100kVAr rack-mounted

1.4.1 PRODUCT DRAWINGS __ 400V CE SVG MODULE

Please refer to Fig. 1-10 for the appearance and size of Ultra CE 400V 30kVAr wall-mounted type.
 Please refer to Fig. 1-11 for the appearance and size of Ultra CE 400V 30kVAr rack-mounted type.
 Please refer to Fig. 1-12 for the appearance and size of Ultra CE 400V 50kVAr wall-mounted type.
 Please refer to Fig. 1-13 for the appearance and size of Ultra CE 400V 50kVAr rack-mounted type.
 Please refer to Fig. 1-14 for the appearance and size of Ultra CE 400V 100kVAr wall-mounted type.
 Please refer to Fig. 1-15 for the appearance and size of Ultra CE 400V 100kVAr rack-mounted type.
 Please refer to Fig. 1-16 for the appearance and size of Ultra CE 400V 200kVAr wall-mounted type.
 Please refer to Fig. 1-17 for the appearance and size of Ultra CE 400V 200kVAr rack-mounted type.

Note: Sinexcel Ultra series, the standard wall mounted is with LCD, the standard rack mounted is with LED. If needs other type module, please discuss with Sinexcel's engineer.

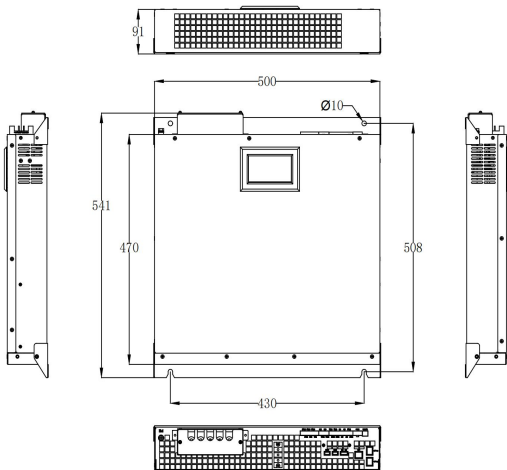

Figure 1- 10 Sinexcel Ultra CE 400V 30kVAr wall-mounted

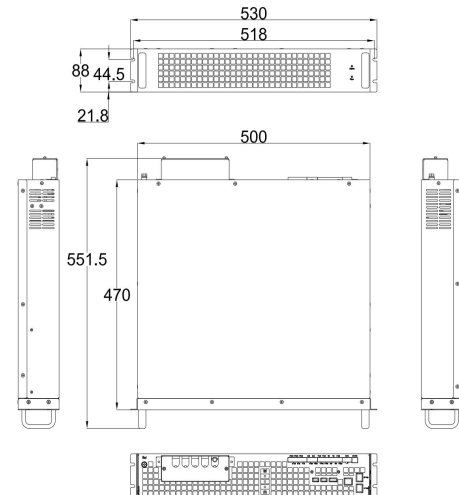

Figure 1- 11 Sinexcel Ultra CE 400V 30kVAr rack-mounted

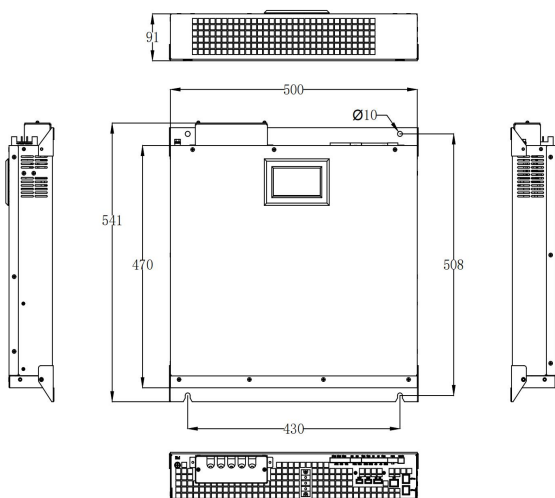

Figure 1- 12 Sinexcel Ultra CE 400V 50kVAr wall-mounted

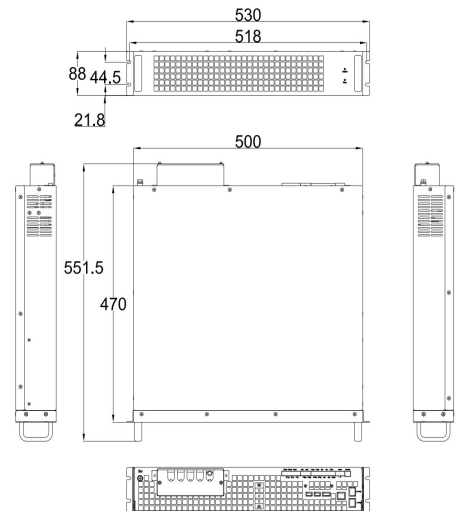

Figure 1- 13 Sinexcel Ultra CE 400V 50kVAr rack-mounted

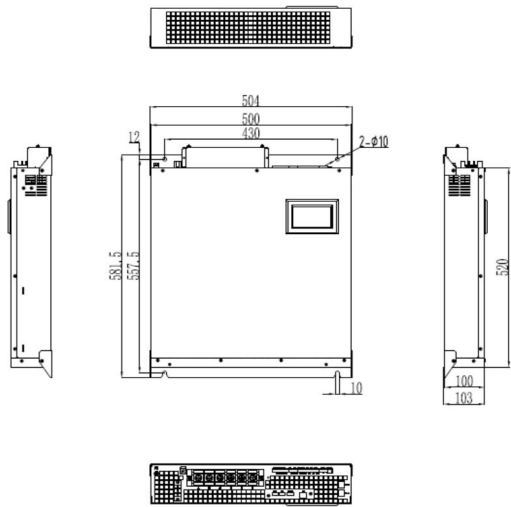

Figure 1- 14 Sinexcel Ultra CE 400V 100kVAr wall-mounted

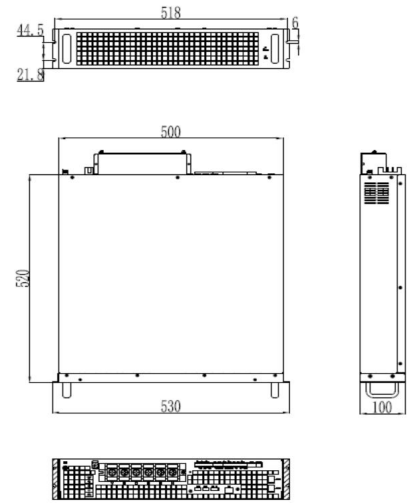

Figure 1- 15 Sinexcel Ultra CE 400V 100kVAr rack-mounted

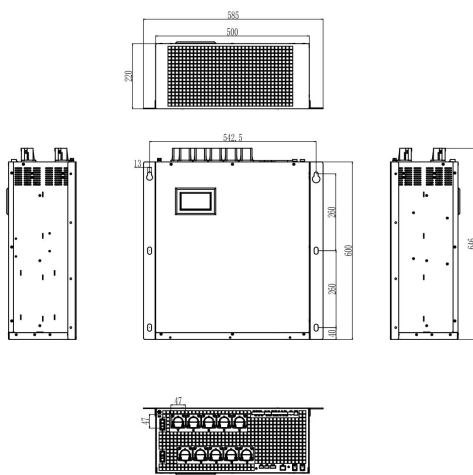

Figure 1- 16 Sinexcel Ultra CE 400V 200kVAr wall-mounted

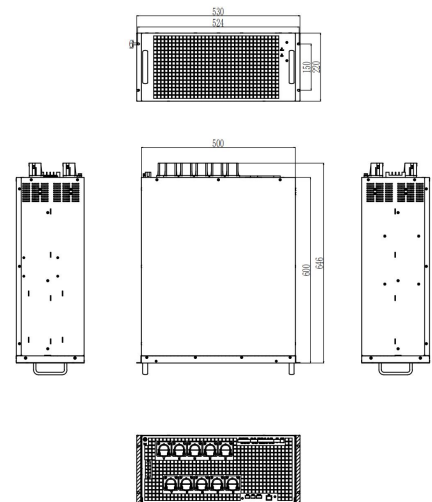

Figure 1- 17 Sinexcel Ultra CE 400V 200kVAr rack-mounted

1.4.3 WIRING TERMINAL

The wiring terminal is located at the rear side of the module, including power terminal, CT terminal and communication terminal.

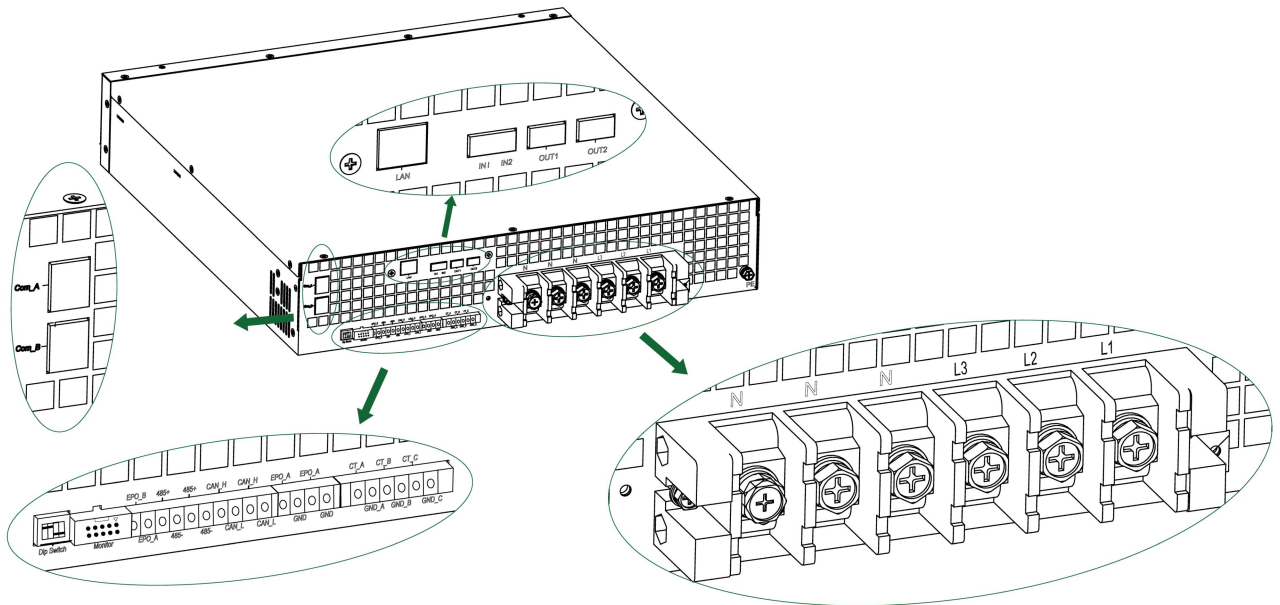

Figure 1- 18 Sinexcel Ultra SVG Terminal

Table 1- 1 Sinexcel Ultra SVG Terminal Definition

Signal terminal	COM_A	422 communication port used for multiple module parallel
	COM_B	422 communication port used for multiple module parallel
	Dip Switch	Communication address setting
	Monitor	7-inch HMI connecting port
	EPO_B	EPO button connecting port
	EPO_A	EPO button connecting port
	485+	485 communication port used for communication between module and 7-inch HMI
	485-	
	485+	
	485-	
	CAN_H	CAN communication port used when SVGD or 422 communication is needed
	CAN_L	
CAN_H		
CAN_L		

	EPO_A	To parallel the EPO signal of each module
	GND	To parallel the EPO signal of each module
	EPO_A	To parallel the EPO signal of each module
	GND	To parallel the EPO signal of each module
	CT_A	Connected to S1 of phase L1 CT
	GND_A	Connected to S2 of phase L1 CT
	CT_B	Connected to S1 of phase L2 CT
	GND_B	Connected to S2 of phase L2 CT
	CT_C	Connected to S1 of phase L3 CT
	GND_C	Connected to S2 of phase L3 CT
	LAN (optional)	Dry contact board terminals (optional), including 1 Ethernet port, 2 input dry contact and 2 output dry contacts, the detailed introduction please refer to Appendix III.
	IN1 (optional)	
	IN2 (optional)	
	OUT1 (optional)	
	OUT2 (optional)	
Power terminal	N	Power cable connection
	N	
	L3	
	L2	
	L1	
	PE	The grounding terminal of a device is an important component that ensures electrical safety.

1.4.3 CABINET SOLUTION

Sinexcel not only provides the modular solution but also cabinet solution, which offers a large capacity, high power density, high integration harmonic compensation system.

The cabinet solution is designed to meet the needs of various industries, including data centers, telecommunications, and industrial applications. It is a reliable and efficient solution that helps customers manage their power systems and ensure their equipment runs smoothly

Table 1- 2 Sinexcel Cabinet Solution

Type	Dimension (W*D*H mm)	Module Inside	Breaker/Isolater	Cable entry	IP grade	Airflow
Flexi Cabinet 1	600*1000*2200	30~100K, 6units in max	Breaker/Isolater Rated current based on modules installed	Top/Bottom cable entry	IP20	Front to Rear
Flexi Cabinet 2	800*800*2200	30~100K, 8units in max				
Flexi Cabinet 3	800*1000*2200	30~100K, 8units in max				
Flexi Cabinet 4	1000*1000*2200	30~100K, 8units in max				
Top vent-W800	800*600*2200	30~100K, 4units in max		Bottom cable entry		Front to Top
Top vent-W1000	1000*600*2200	30~100K, 5units in max				
Top vent-W1200	1200*600*2200	30~100K, 6units in max				
IP54 Cabinet- 1800H	700*900*1800	30~100K, 5units in max		Bottom cable entry	IP54	Front to Rear
IP54 Cabinet- 2200H	1000*1000*2200	30~100K, 6units in max				

The Sinexcel Flexi Cabinet 1-4 series cabinets are designed to host Sinexcel rack-mounted modules within the cabinet.

The Sinexcel Top-vent series cabinets can be installed directly against the wall. The cabinets are designed to host Sinexcel wall-mounted modules.

The size Sinexcel provided for Flexi Cabinet and Top-Vent cabinet in the table, which not including the structure of the door.

Note: The table only list the Sinexcel Ultra module solution, if need other type module cabinet solution, please contact the Sinexcel's engineer;

1.4.3.1 FLEXIBLE CABINET

Four sizes optional: The Sinexcel Flexible Cabinet offers customers the flexibility to choose from four different size options. This allows customers to select the size that best fits their specific needs and requirements. By offering multiple size options, Sinexcel ensures that customers can find the right cabinet for their specific application.

Multiple capacities can choose: In addition to the four size options, the Sinexcel Flexible Cabinet also offers customers multiple capacity configurations to choose from, Sinexcel support to install 100~800K SVG capacity inside of the cabinet.

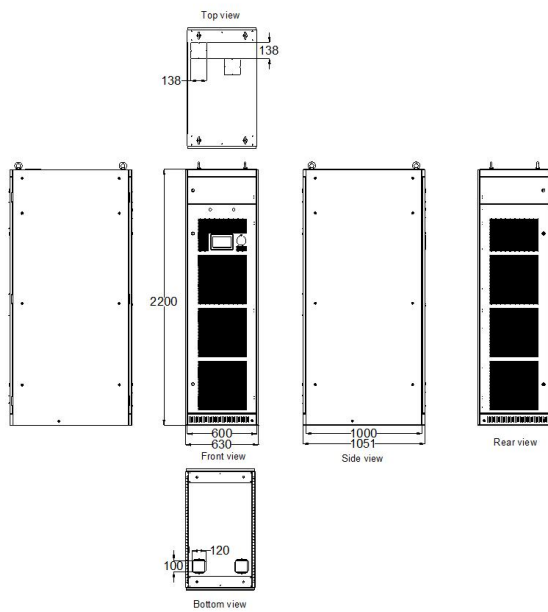

Figure 1- 19 Standard Cabinet 600*1000*2200

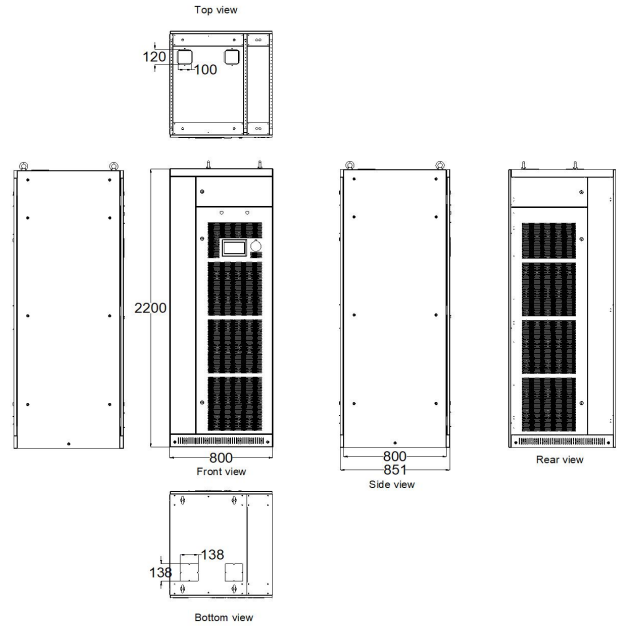

Figure 1- 20 Standard Cabinet 800*800*2200

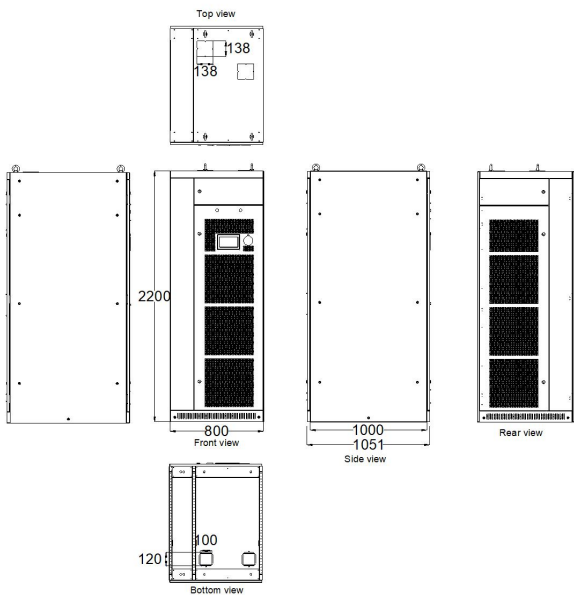

Figure 1- 21 Standard Cabinet 800*1000*2200

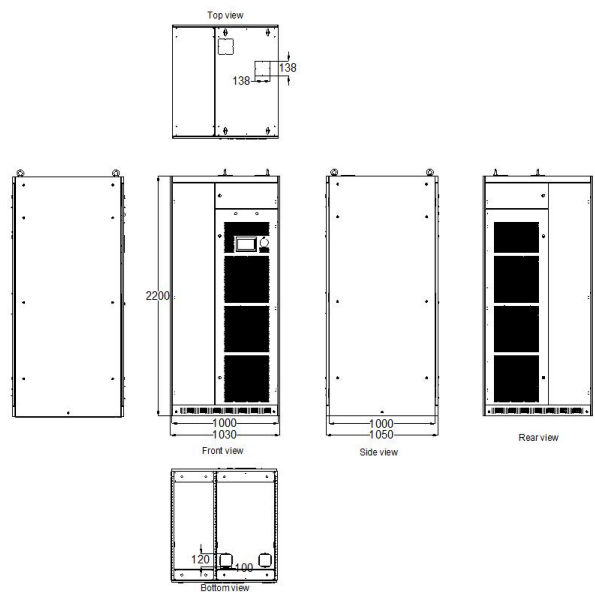

Figure 1- 22 Standard Cabinet 1000*1000*2200

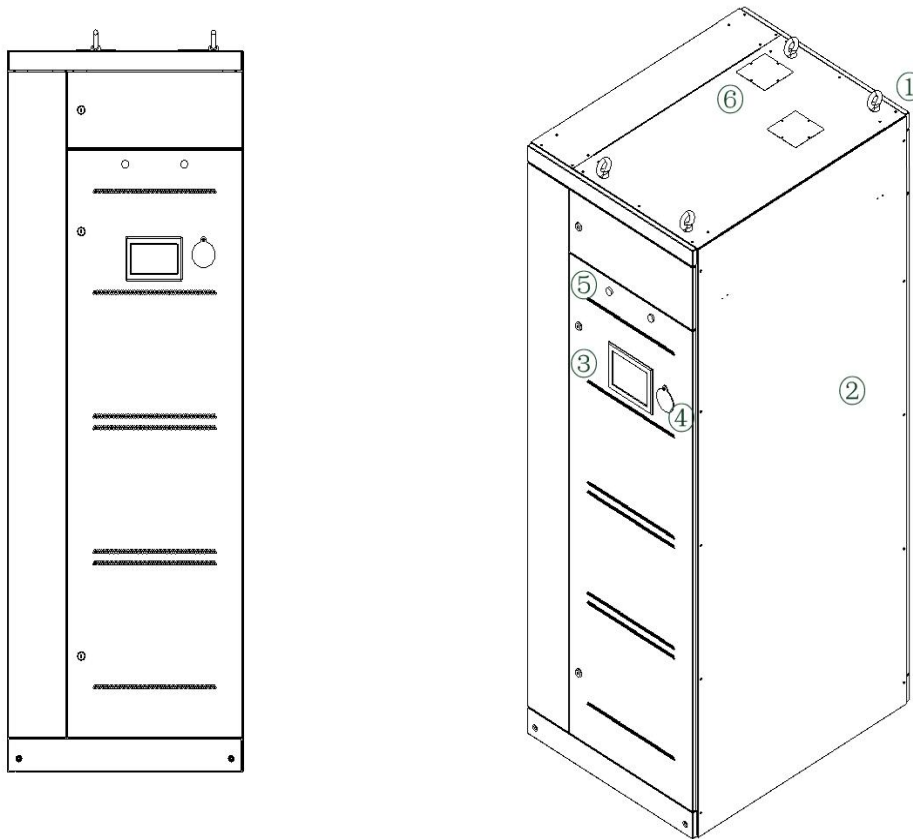

Figure 1- 23 Structure of Sinexcel Flexi Cabinet

Table 1- 3 The definition of Sinexcel Flexi Cabinet structure

No.	Name	Number	Description
①	Lifting ring	4	The top of the cabinet frame is provided with a hole for the ring bolt, allowing the lifting mechanism and the ring bolt to lift the cabinet for movement and placement.
②	Panel	6	Front panel, back panel, right panel, left panel, top panel and bottom panel, which are made by Aluminum Zinc.
③	HMI	1	7-inch human-machine interface, which support to see data convenient for customer, like voltage, current and PF. Full touch screen color screen operation.
④	EPO button	1	Emergency Power Off, when an emergency occurs, which press the button to stop the cabinet system from working immediately.
⑤	Indicator	2	The red indicator and green indicator. When system is standby/running, the green indicator is lights on. When system is in the status of alarm, the red indicator is light on.
⑥	Cable entry	2	Used for the incoming cables, no restrict for incoming cables position.

Note: Sinexcel Flexi Cabinet 1 (600*1000*2200mm), the copper low is the back position of the cabinet; The other 3 types of cabinets, the copper low are in the side cabinet.

1.4.3.2 TOP-VENT CABINET

Sinexcel's top-vent cabinet is a versatile and space-saving solution that can be directly installed against the wall. The cabinet is available in two different sizes, providing customers with 2 options to choose according on their specific needs and requirements.

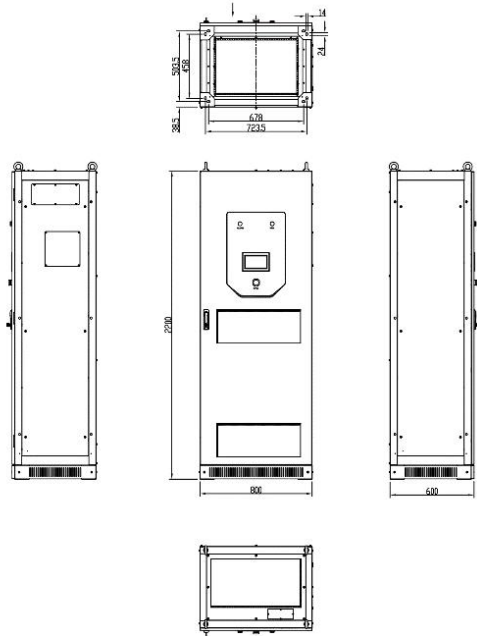

Figure 1- 24 Top vent W800 Cabinet 800*600*2200

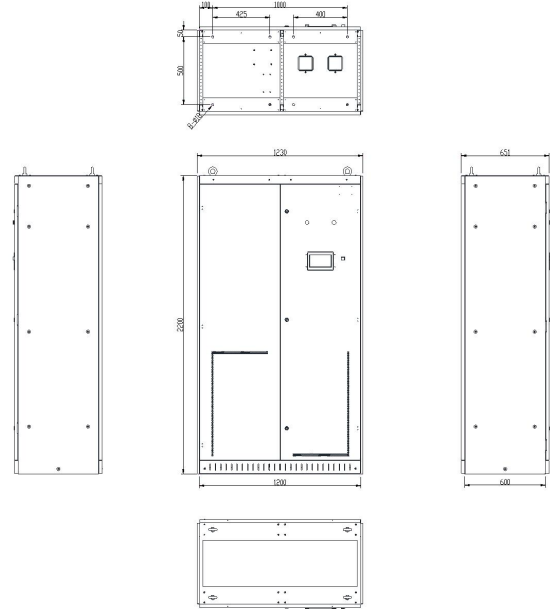

Figure 1- 25 Top vent W1200 Cabinet 1200*600*2200

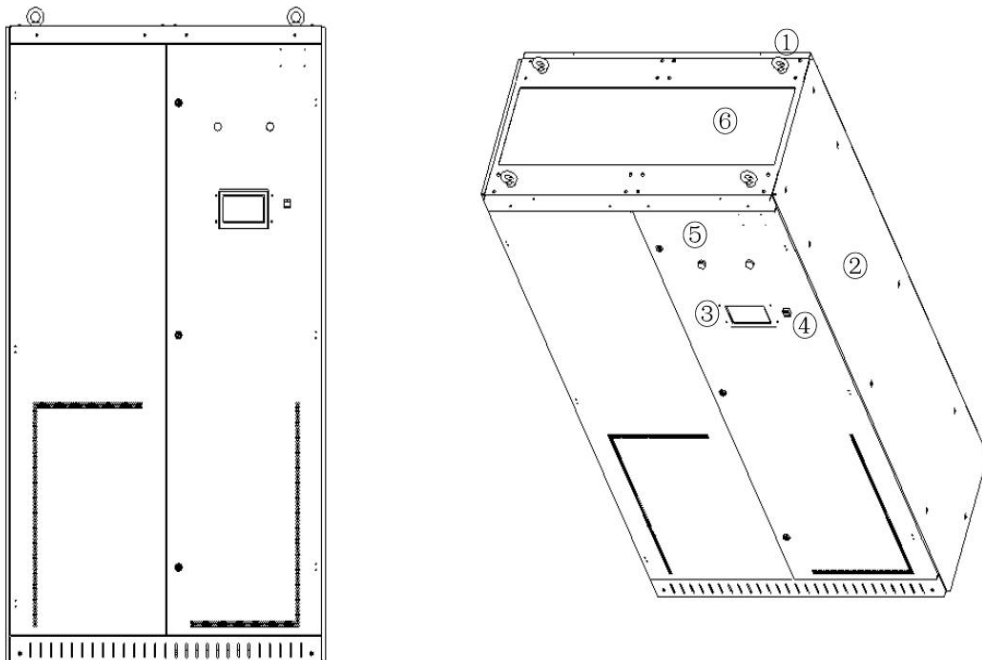

Figure 1- 26 Structure of Sinexcel Top-Vent Cabinet

Table 1- 4 The definition of Sinexcel Top-Vent Cabinet structure

No.	Name	Number	Description
①	Lifting ring	4	The top of the cabinet frame is provided with a hole for the ring bolt, allowing the lifting mechanism and the ring bolt to lift the cabinet for movement and placement.
②	Panel	6	Front panel, back panel, right panel, left panel, top panel and bottom panel, which are made by Aluminum Zinc.
③	HMI	1	7-inch human-machine interface, which support to see data convenient for customer, like voltage, current and PF. Full touch screen color screen operation.
④	EPO button	1	Emergency Power Off, when an emergency occurs, which press the button to stop the cabinet system from working immediately.
⑤	Indicator	2	The red indicator and green indicator. When system is standby/running, the green indicator is lights on. When system is in the status of alarm, the red indicator is light on.
⑥	Cable entry	1	Used for the incoming cables.

1.4.3.3 IP54 CABINET

Sinexcel's IP54 cabinet is a high-protection level solution that is designed to provide superior protection against dust and water. This makes it ideal for harsh environments and outdoor applications. The cabinet is available in two different sizes, providing customers with 2 options to choose according to their specific needs and requirements.

The two different sizes of IP54 cabinets offered by Sinexcel provide customers with flexibility in choosing the right cabinet for their specific application. The smaller size is ideal for applications with limited space, while the larger size is suitable for applications that require bigger capacity solution.

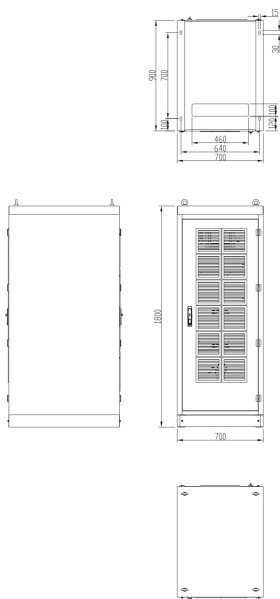

Figure 1- 27 IP54 Cabinet 700*900*1800

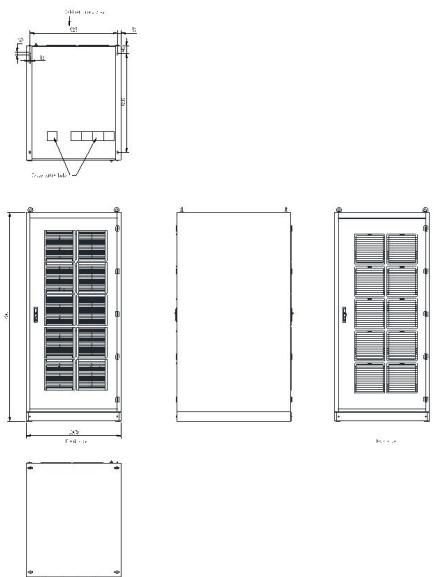

Figure 1- 28 IP54 Cabinet 1000*1200*2200

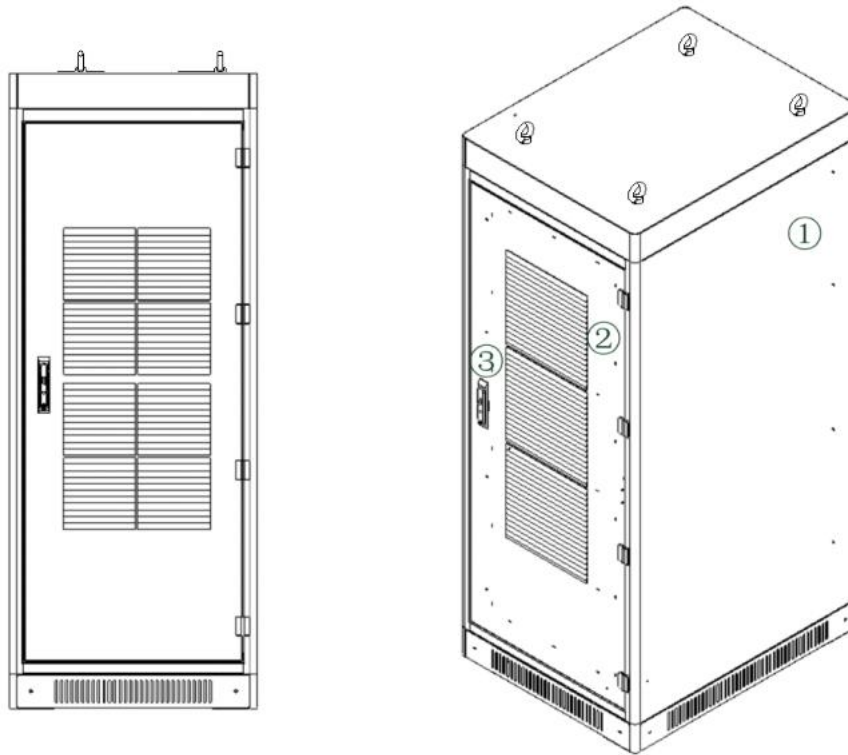

Figure 1-29 Structure of Sinexcel IP54 Cabinet

Table 1-5 The definition of Sinexcel IP54 Cabinet structure





No.	Name	Number	Description
①	Panel	6	Front panel, back panel, right panel, left panel, top panel and bottom panel, which are made by hot-dip galvanized / cold-rolled steel sheets / aluminum-zinc coated sheets.
②	Blinds	3	Better for ventilation and heat dissipation
③	Handle	1	Zinc alloy base, the lock cylinder is rotated 180° to open, press the button, the handle will pop up automatically, driving the transmission shell assembly to realize opening or locking.

Note:

- If the cabinet is protected by spraying with hot-dip galvanized sheet;
- If the cabinet is protected without spraying or electroplating is used with cold-rolled steel sheet;
- The internal structural parts are made of aluminum-zinc coated sheet;
- The thickness of the sheet is more than 3mm, a hot-rolled steel sheet is used.

CHAPTER II INSTALLATION AND WIRING







2.1 PRE-INSTALLATION NOTICE

	<p>CAUTION</p> <p>The installation, assembly and power on of the module must be operated by qualified personnel or supervised by qualified personnel on-site.</p>
	<p>CAUTION</p> <p>Before wiring or connecting terminals, make sure that the input of the SVG has been turned off so as to avoid accidents.</p>
	<p>CAUTION</p> <p>This equipment has the leakage current from 3.5mA to 1000mA. Before connecting power supply, the user must make sure the equipment is properly grounded.</p> <p>When choosing RCCB or RCD equipment, the leakage current of the module should be considered.</p> <p>The RCCB chosen should not be sensitive to the unidirectional DC pulse (Class A) and the transient pulse.</p> <p>Please note that the leakage current of the load will also flow through RCCB or RCD; the grounding of the device must meet the local electrical regulations</p>
	<p>CAUTION</p> <p>Sinexcel Ultra SVG should be installed in a clean, well-ventilated indoor environment.</p>

2.2 ENVIRONMENT REQUIREMENTS

	<p>ATTENTION</p> <p>The cold air enters SVG through the front grid of the module and hot air is discharged through the rear grid of the module. Do not block the ventilation holes on either side and clean the front grid every 3 months to prevent blockage by dust.</p>
---	---

Before proceeding, it is important to take note of the preconditions required for the environment.

	<p>ATTENTION</p> <p>The ambient temperature at the time of installation must be -10°C ~40°C.</p>
	<p>ATTENTION</p> <p>Ensure that there is no dust (can be conductive) or corrosive/explosive gases in the installation environment.</p>
	<p>ATTENTION</p> <p>The SVG MUST NOT be installed in an environment with strong magnetic fields, nuclear radiation or high-power RF noise.</p>
	<p>ATTENTION</p> <p>The relative humidity in the environment should be lower than 95%. The presence of steam or condensation may result in permanent damage to the device or endanger personal safety.</p>
	<p>ATTENTION</p> <p>The installation altitude should be lower than 1500m. If it is over 1500m, the equipment must be de-rated 1% per 100m increase in altitude.</p>
	<p>ATTENTION</p> <p>Avoid severe physical shock, violent impact and large angle tilting in the installation process as this may cause damage and operational failure of the unit.</p>
	<p>ATTENTION</p> <p>During installation, leave sufficient operating space for cooling, maintenance and operation.</p>

2.3 INSTALLATION



NOTICE

All the modules have the dust-proof stickers to protect the module from the dust while storing. The dust-proof stickers must be removed before the module is installed at site.

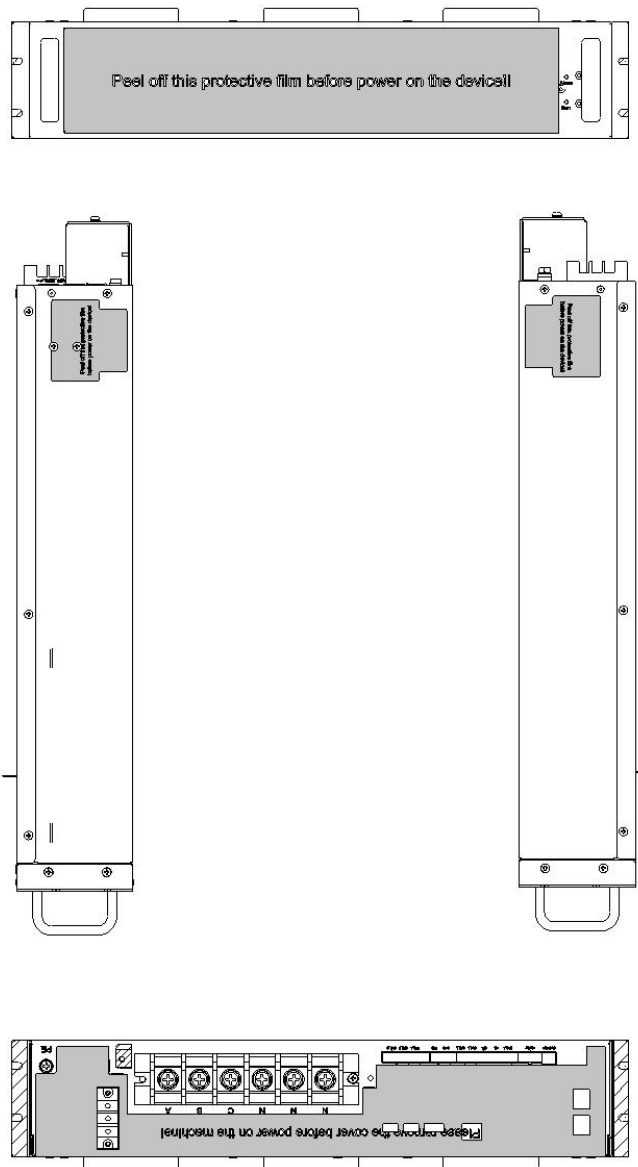



Figure 2- 1 Dust-proof sticker

2.3.1 WALL-MOUNTED

	<p>NOTICE</p> <p>For the wall-mount module, the distance from top side of the unit to the ceiling should be at least 500mm, and the bottom side should be at least 800mm from the floor.</p>
---	---

For wall mount module, the fixing screws are located at the top and bottom of the module. The module must be fixed vertically to a wall or support, using 4 screws with a diameter of 6mm to be suitable for the chosen wall or support.

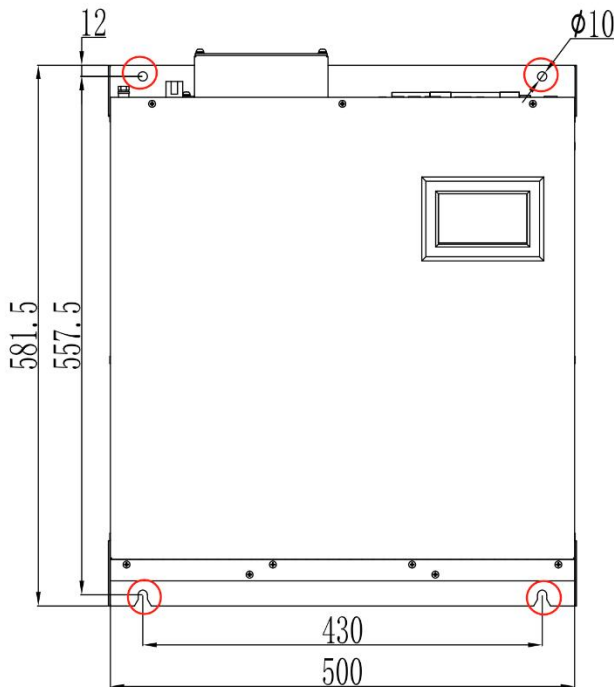

Figure 2- 2 Front Side

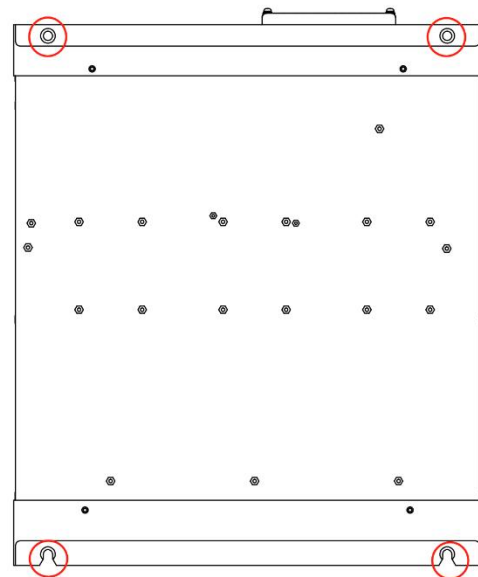



Figure 2- 3 Rear Side

2.3.2 RACK-MOUNTED

	<p>NOTICE</p> <p>For the rack-mount module, the distance from the rear side of the unit to the wall should be at least 500mm, and the front side should be at least 800mm from the wall to allow for module extraction or insertion. Please contact Sinexcel if other occasions.</p>
---	---

There are four screws on the module that need to be installed for fixation, with a diameter of thread with a major diameter of 6 and a pitch of 12 to be suitable for the cabinet, switch gear.

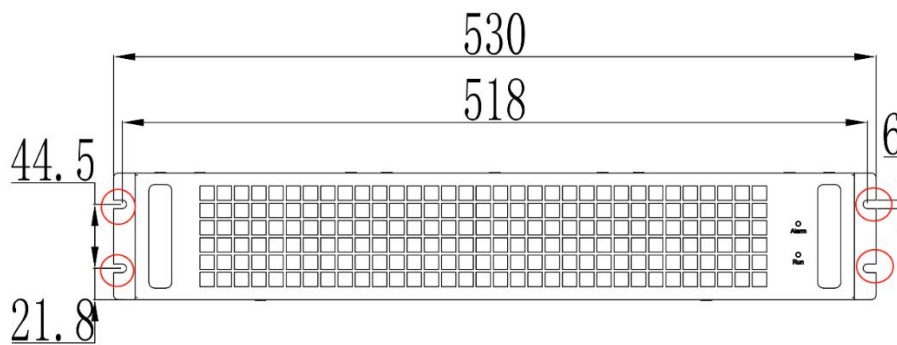

Figure 2- 4 Rack-mounted Rear side

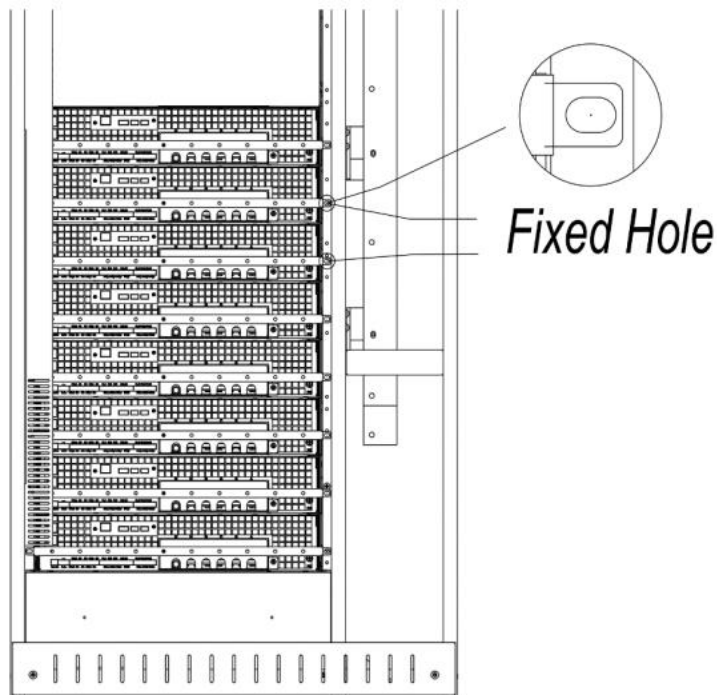

Figure 2- 5 Cabinet Fixed Hole

2.3.3 CABINET

2.3.3.1 FLEXIBLE CABINET

Handling facilities are applied for transport through the 4 hanging rings on the top of the cabinet;

Corresponding handling facilities are applied for transport through the bottom of the cabinet.

Note: When moving the cabinet from the bottom of its front, disassemble the front and rear panel at the bottom. When the cabinet is moved to the designated position, reattach the front and rear.



Figure 2- 6 Cabinet Transportation

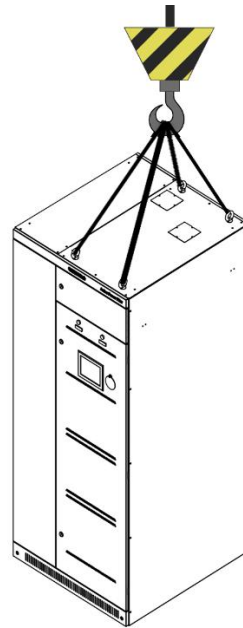



Figure 2- 7 Lifting Cabinet

Sinexcel flexible cabinet is free-standing cabinet with 4 bearing supports on the ground.

	<p>NOTICE</p> <p>For the flexible cabinet, the distance from the rear side of the unit to the wall should be at least 800mm, and the front side should be at least 1000mm from the wall to allow for module extraction or insertion. Please contact Sinexcel if other occasions.</p>
	<p>NOTICE</p> <p>For the flexible cabinet, the distance from the right side of the unit to the wall should be at least 500mm, and the left side should be at least 500mm from the wall to allow for module extraction or insertion. Please contact Sinexcel if other occasions.</p>

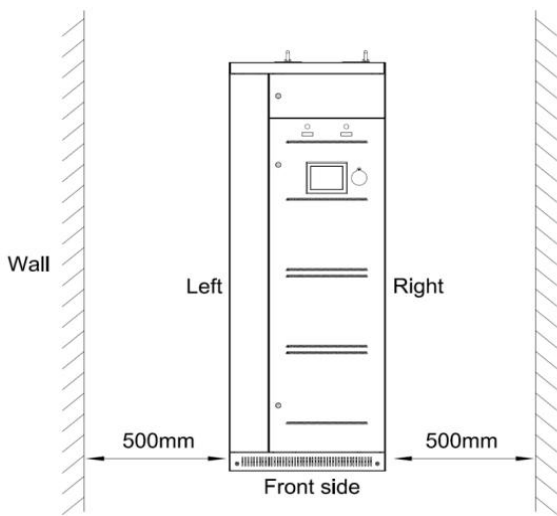

Figure 2- 8 Front side

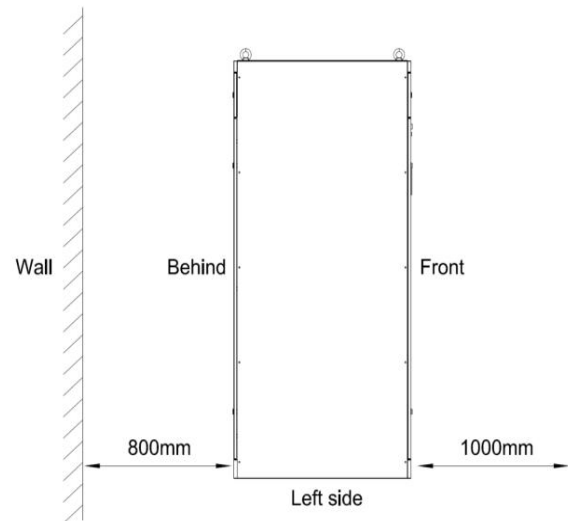

Figure 2- 9 Rear side

2.3.4 TOP-VENT CABINE

Handling facilities are applied for transport through the 4 hanging rings on the top of the cabinet;

Corresponding handling facilities are applied for transport through the bottom of the cabinet.

Note: When moving the cabinet from the bottom of its front, disassemble the front and rear panel at the bottom. When the cabinet is moved to the designated position, reattach the front and rear panel.

Sinexcel top-vent cabinet is free-standing cabinet with 4 bearing supports on the ground.

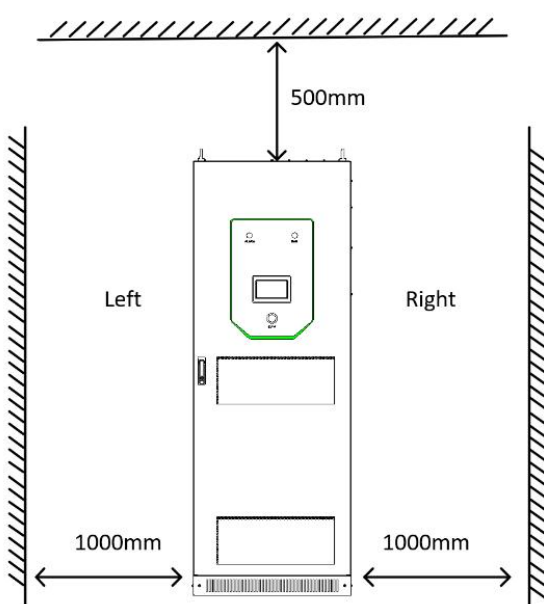

Figure 2- 10 Front side

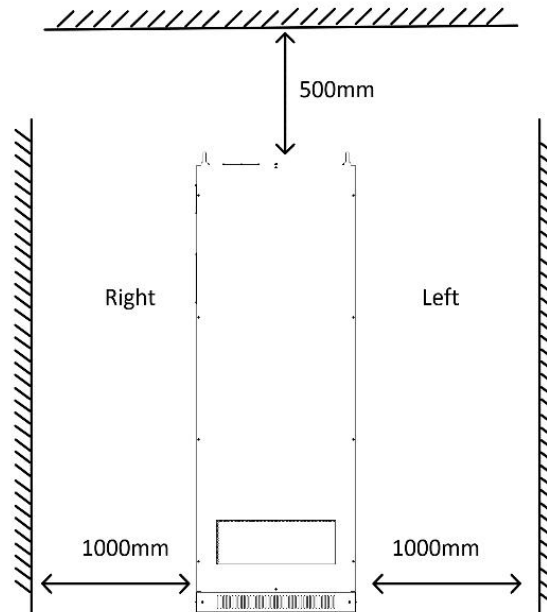





Figure 2- 11 Rear side

	<p>NOTICE</p> <p>For the top-vent cabinet, the distance from the front side of the unit to the wall should be at least 1000mm to allow for module extraction or insertion. Please contact Sinexcel if other occasions.</p>
	<p>NOTICE</p> <p>For the flexible cabinet, the distance from the top side of the unit to the wall should be at least 500mm to allow for module extraction or insertion. Please contact Sinexcel if other occasions.</p>

2.3.5 IP54 CABINET

Corresponding handling facilities are applied for transport through the bottom of the cabinet.

Note: When moving the cabinet from the bottom of its front, disassemble the front and rear panel at the bottom. When the cabinet is moved to the designated position, reattach the front and rear panel.

	<p>NOTICE</p> <p>For the flexible cabinet, the distance from the rear side of the unit to the wall should be at least 800mm, and the front side should be at least 1000mm from the wall to allow for module extraction or insertion. Please contact Sinexcel if other occasions.</p>
---	---

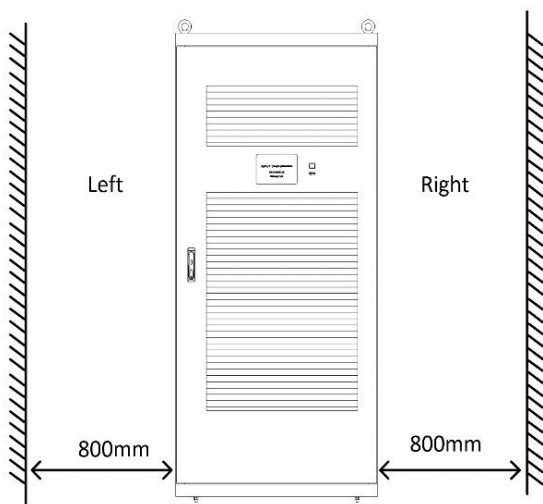

Figure 2- 12 Front side

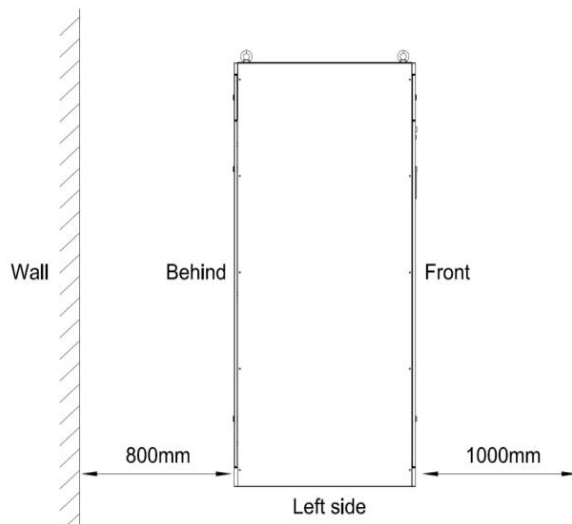

Figure 2- 13 Rear side

2.4 CONNECTION



DANGER

Before connecting the cables or electronics, please be sure to cut off the input power of the SVG device to avoid accidents.

2.4.1 SINGLE WALL MOUNTED

Table 2- 1 Installation Steps of Sinexcel Single Wall-mounted Module

<p>Step One: Power Cables Connection</p>	<p>Step Two: CT Connection</p>
<p>Step Three: 7-Inch HMI Connection</p>	
<p>Note: If user need to use 7-inch Human-machine interface (HMI) to control the module, which need to operate as STEP THREE;</p>	

2.4.2 MULTIPLE WALL MOUNTED

Table 2- 2 Installation Steps of Sinexcel Multiple Wall-mounted Modules

Step One: Power Cables Connection

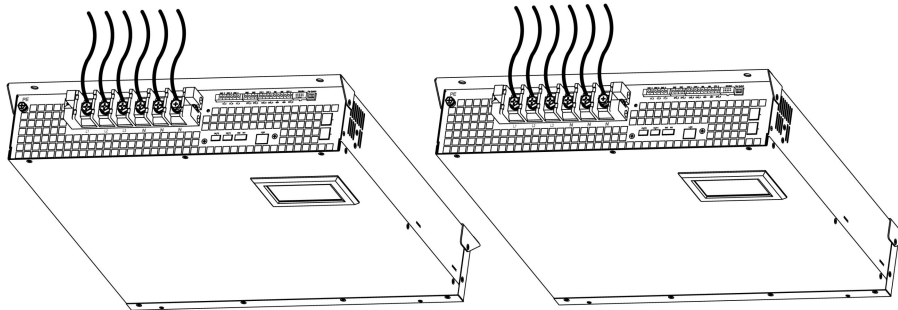

Step Two: L1 Phase CT Connection

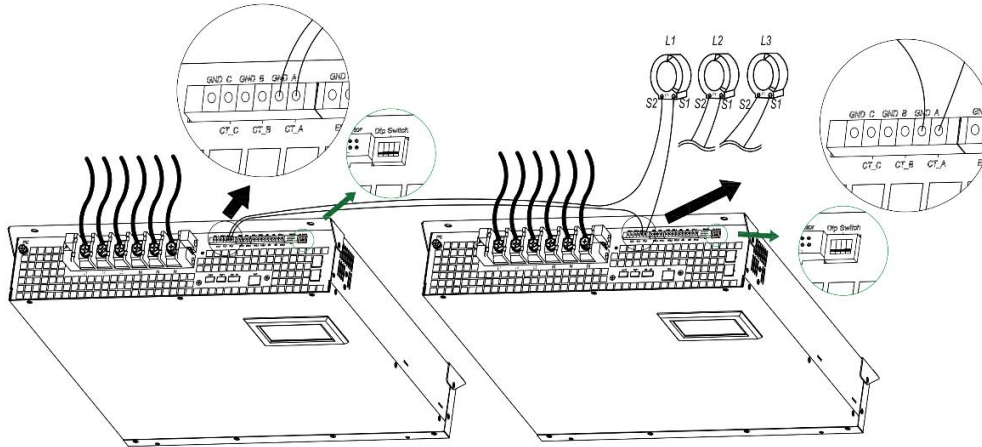

Step Three: L2 Phase CT Connection

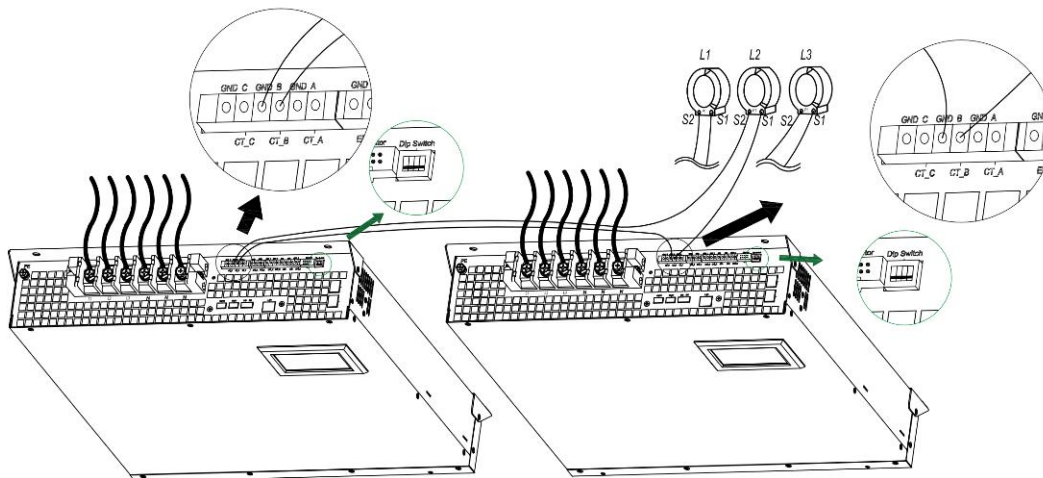

Step Four: L3 Phase CT Connection

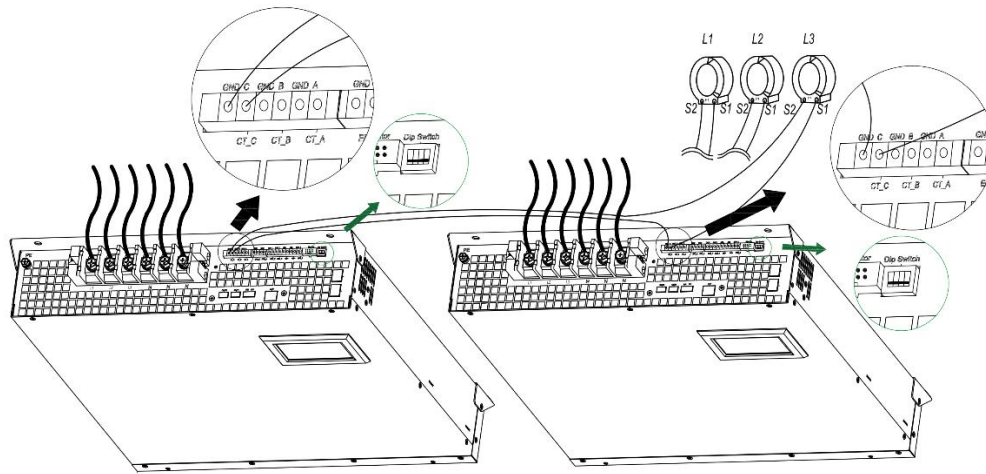

Step Five: 7-Inch HMI Connection

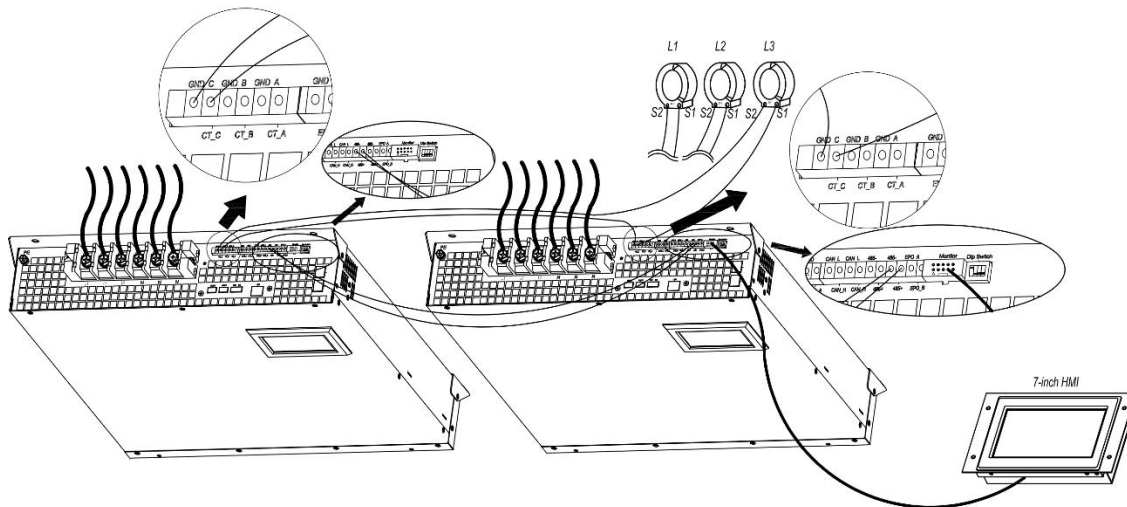

Note: If user need to use 7-inch Human-machine interface (HMI) to control the module, which need to operate as **STEP FIVE**:

2.4.3 SINGLE RACK MOUNTED

Table 2- 3 Installation Steps of Sinexcel Single Rack-mounted Module

Step One: Power Cables Connection

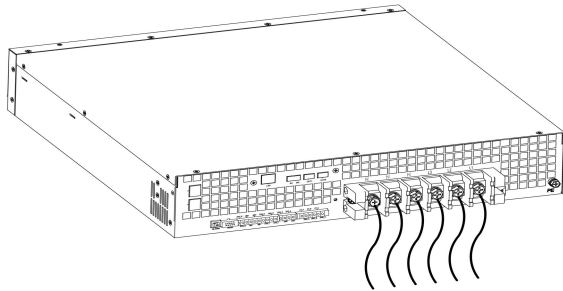

Step Two: CT Connection

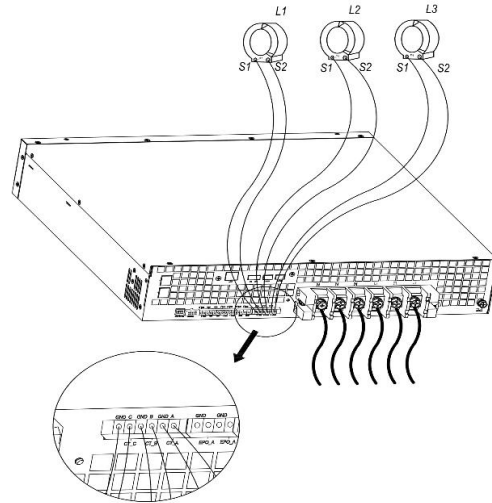

Step Three: 7-Inch HMI Connection

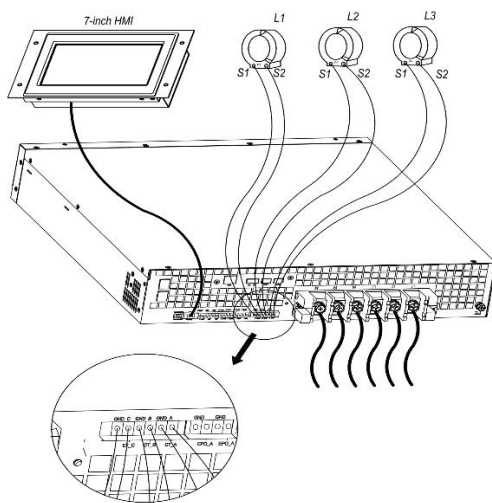

2.4.4 MULTIPLE RACK MOUNTED

Table 2- 4 Installation Steps of Sinexcel Multiple Rack-mounted Modules

Step One: Power Cables Connection

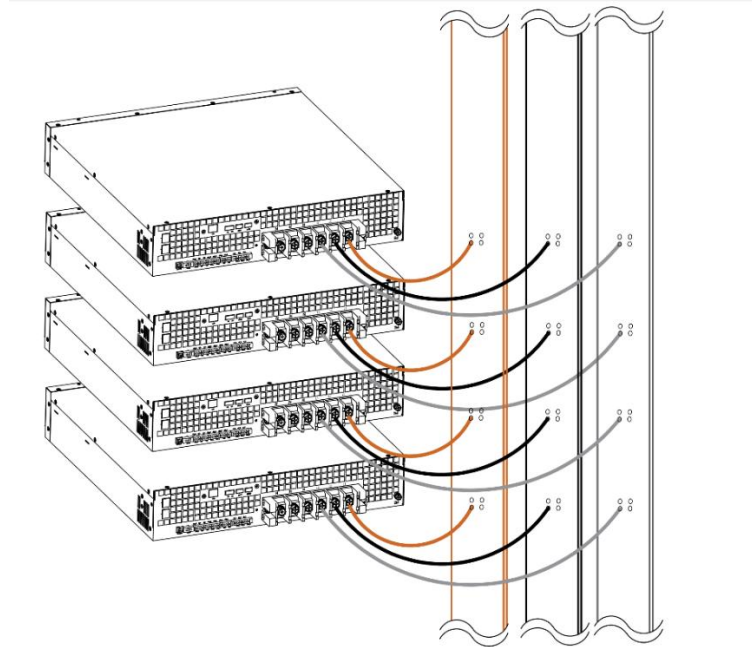

Step Two: L1 Phase CT Connection

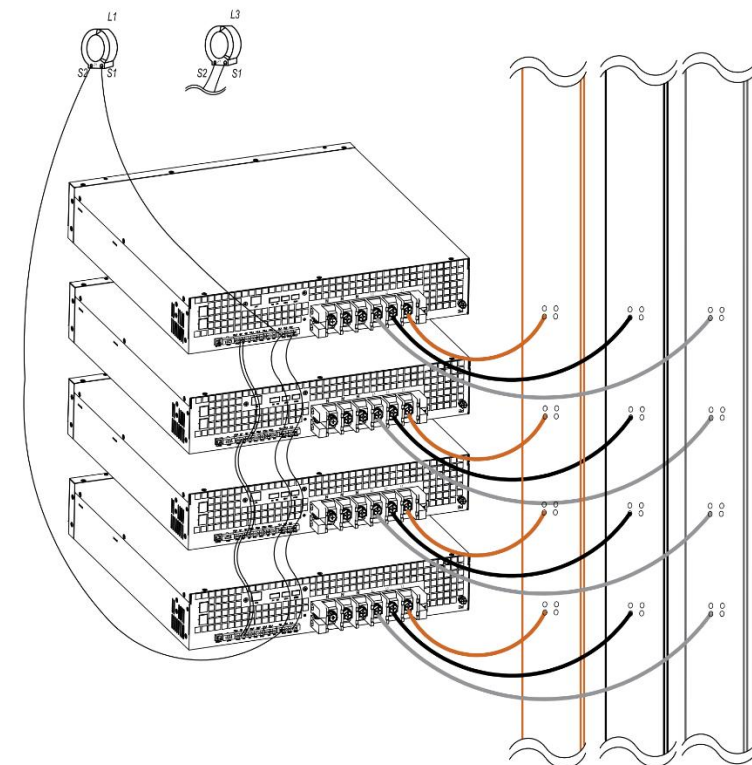

Step Two: L3 Phase CT Connection

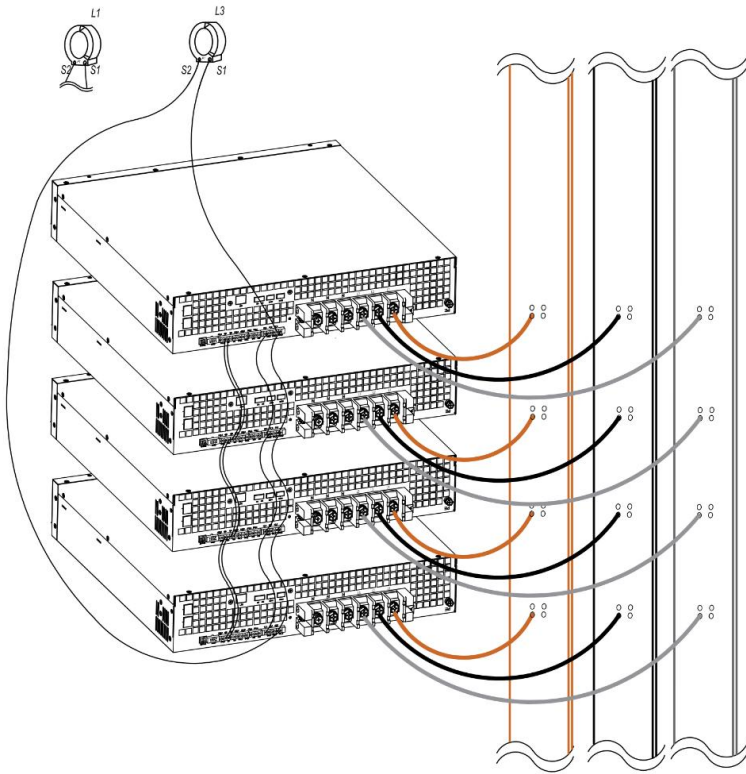

Step Four: 7-Inch HMI Connection

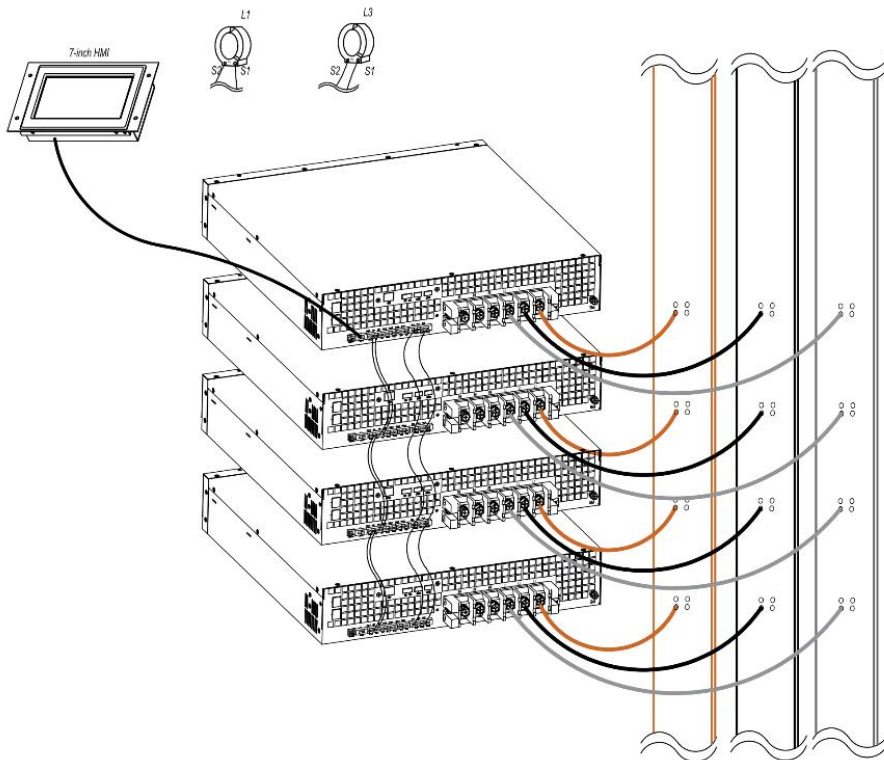

2.4.5 CABINET

Table 2- 5 Installation Steps of Sinexcel Cabinet

Step One: Power Cables Connection

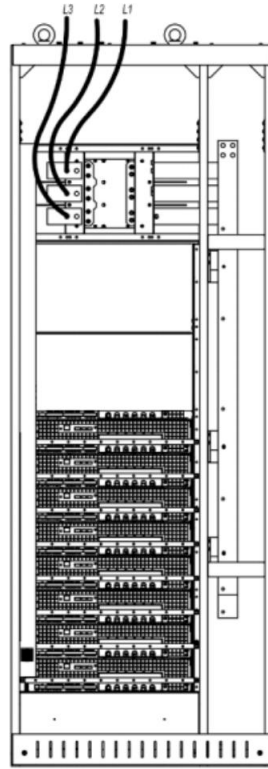

Rear view

Step Two: CT Connection

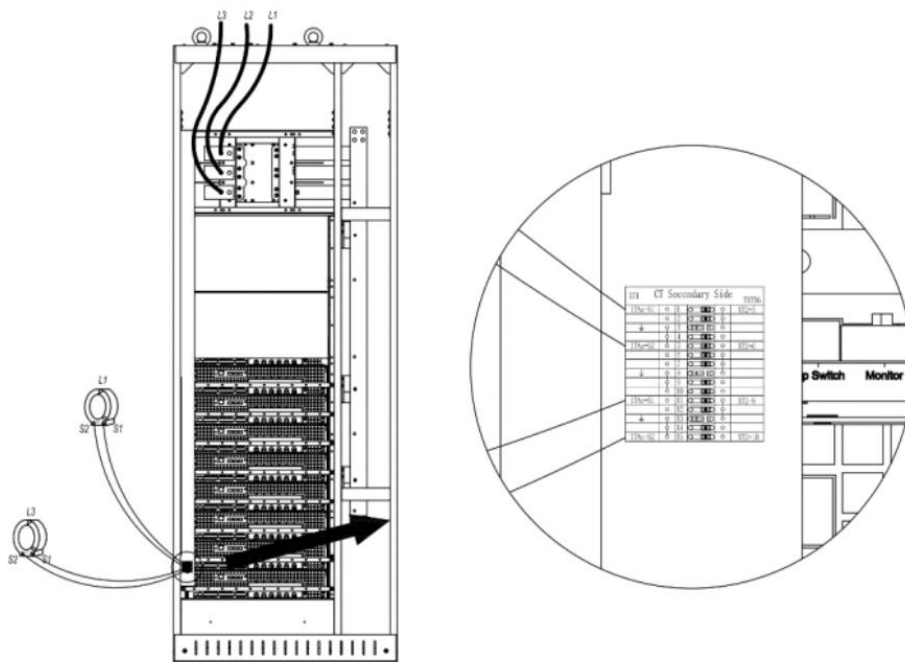

Rear view

Cabinet connection notice:

	<p>WARNING</p> <p>Must be performed by qualified engineers.</p>
	<p>WARNING</p> <p>Before wiring, make sure the switch in distribution room of SVG system input power and city power are in “off” state, and warning label is attached to prevent any other person from handling the switch.</p>
	<p>NOTICE</p> <p>Confirm all input distribution power switches are completely off</p>
	<p>NOTICE</p> <p>Connect protective grounding and other necessary ground cables to earth point PE; all SVG cabinets must be connected to user grounding.</p>
	<p>WARNING</p> <p>Earth wire connection must comply with international relevant standards.</p>
	<p>WARNING</p> <p>Failure to conduct ground installation according to requirement may lead to electromagnetic interference, electric shock and fire.</p>

2.5 CABLE

2.5.1 POWER CABLE



	<p>CAUTION</p> <p>For 3P3W system only needs to connect L1, L2 and L3; For 3P4W system needs to connect L1, L2, L3 and N.</p>
---	--

Power cables are electrical cables that are used to transmit electrical power from a power source to a device or equipment. They are typically made of copper or aluminum conductors and are insulated to prevent electrical shock and short circuits. Power cables come in various sizes and configurations, depending on the amount of power that needs to be transmitted and the distance between the power source and the device or equipment.

2.5.1.1 POWER CABLE SELECTION

If you need a clear power cable selection, please refer to Appendix VII 'CABLE SIZING', where we have recommended the appropriate sizes for you. You can use this as a reference to select the proper power cable for your specific application.

2.5.1.2 CT CABLE CONNECTION

	<p>CAUTION</p> <p>An open circuit of CT secondary polarity is not allowed.</p>
	<p>NOTICE</p> <p>Sinexcel module is support 3P3W and 3P4W at the same time, according to circuit calculation, for 3P3W system only needs two CTs connect to L1 and L3; For 3P4W system needs three CTs connect to L1, L2 and L3.</p>
	<p>NOTICE</p> <p>To ensure current sharing between the modules, such mode of connection requires the same Cable length from S1 and S2 to the two module signal interfaces. Generally, the parallel cable should not be more than 15m in length. If the parallel operation cable with a length of over 30m is required, please see the introduction of Appendix VIII 'CT VA BURDEN'.</p>

2.5.1.3 SINGLE MODULE

CT CONNECTIS ON THE LOAD SIDE

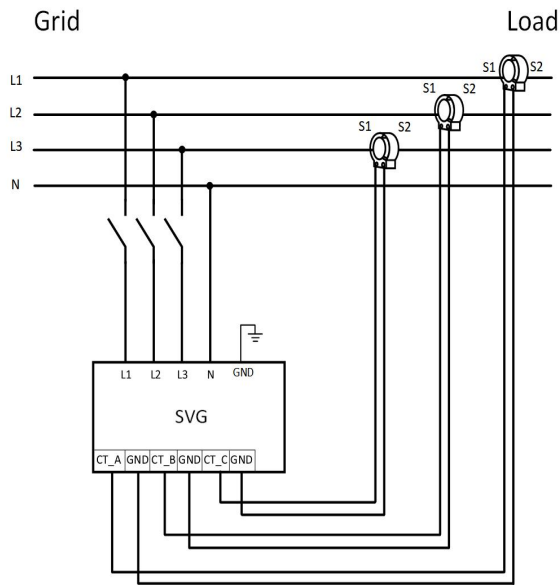

Figure 2- 14 3-Phase 4-Wiring System

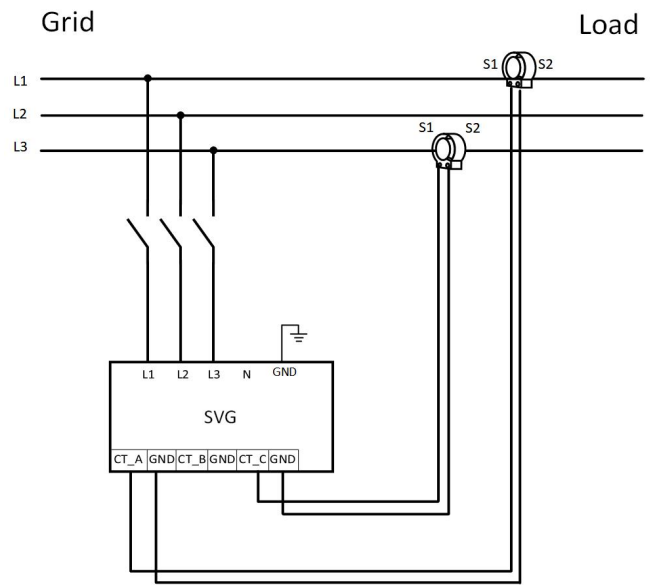

Figure 2- 15 3-Phase 3-Wiring System

CT CONNECTIS ON THE SUPPLY SIDE

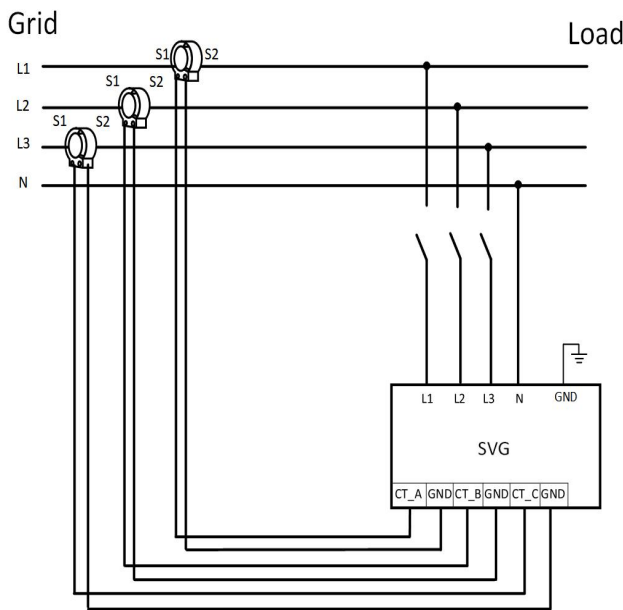

Figure 2- 16 3-Phase 4-Wiring System

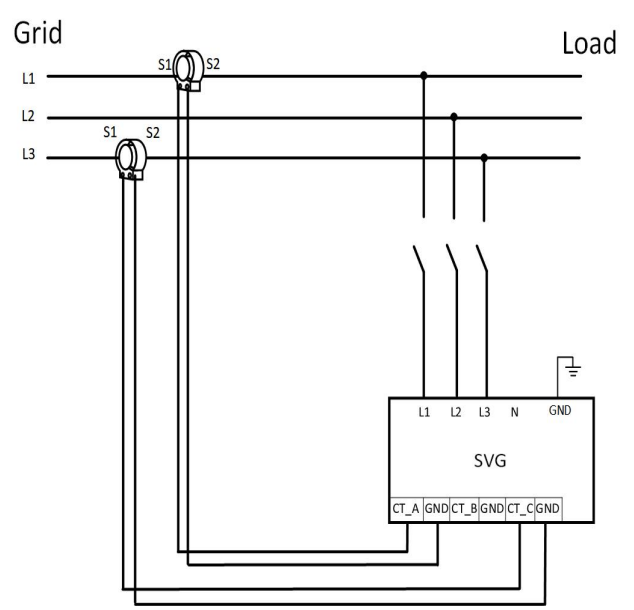

Figure 2- 17 3-Phase 3-Wiring System

2.5.1.4 MULTIPLE MODULES

CT CONNECTIS ON THE LOAD SIDE

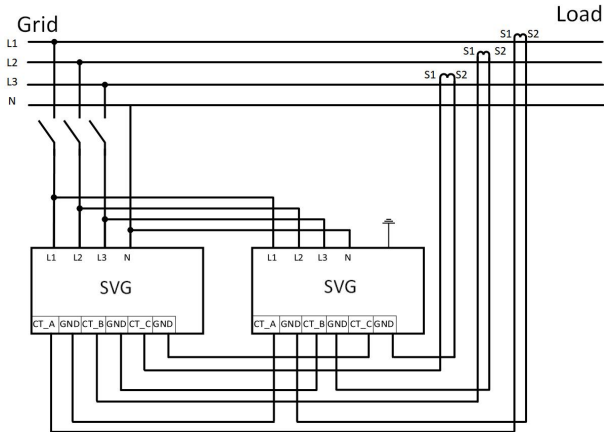

Figure 2- 18 3-Phase 4-Wiring System

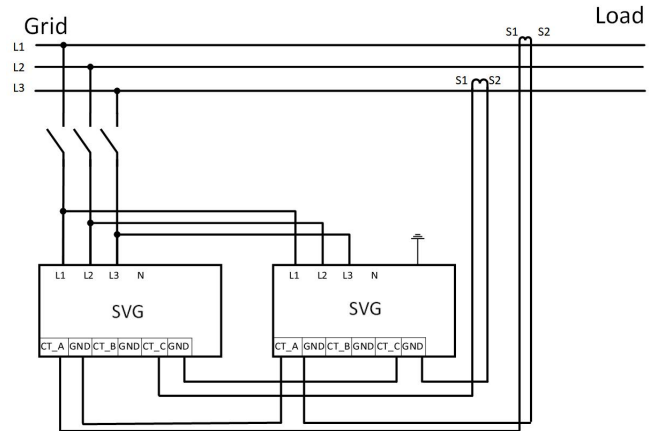

Figure 2- 19 3-Phase 3-Wiring System

CT CONNECTIS ON THE SUPPLY SIDE

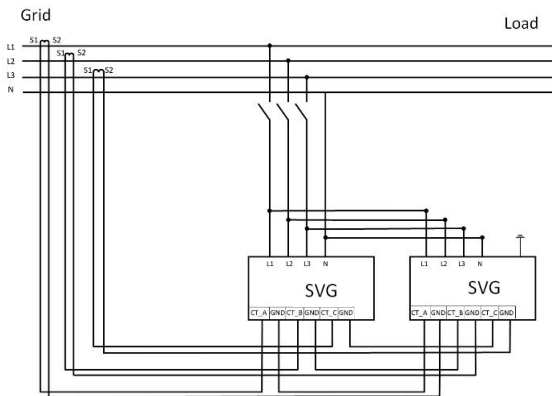

Figure 2- 20 3-Phase 4-Wiring System

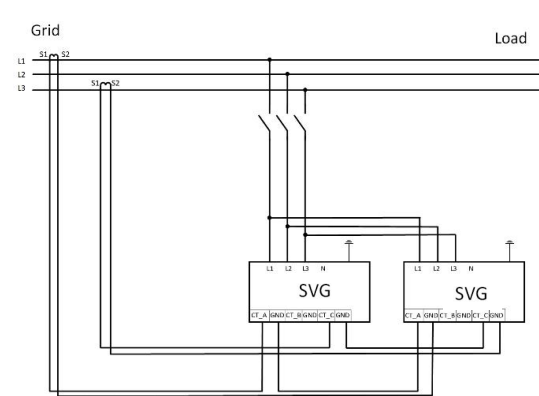

Figure 2- 21 3-Phase 3-Wiring System

CT CLOSED LOOP DESIGN__ONE SET OF CT INSTALLATION FOR MULTIPLE MODULES IN SUPPLY SIDE

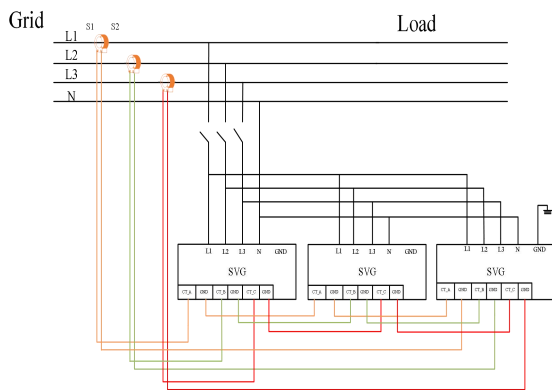

Figure 2- 22 3-Phase 4-Wiring System

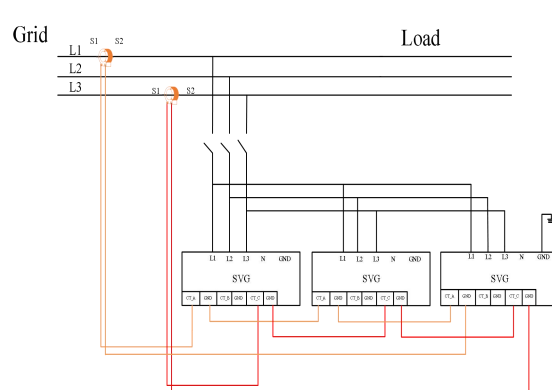





Figure 2- 23 3-Phase 3-Wiring System

2.5.1.5 CABINET

	<p>CAUTION</p> <p>An open circuit of CT secondary side when there is load current exists is forbidden.</p>
	<p>NOTICE</p> <p>Sinexcel module is support 3P3W and 3P4W at the same time, according to circuit calculation, for 3P3W system only needs two CTs connect at L1 and L3; For 3P4W system needs three CTs connect at L1, L2 and L3.</p>
	<p>NOTICE</p> <p>Once external CT is installed at the power distribution, CT secondary side terminal must be short-circuited and disconnected after CT secondary side cable is connected to the corresponding terminal. Users need to configure this short circuit device by themselves when connecting CT. Make sure that all secondary side GND ends of three-phase L1re short-circuited and connected to SVG PE line before CT is connected to the system, so as to ensure the safety of operator.</p>
	<p>NOTICE</p> <p>The following procedures need to be taken when the device needs maintenance:</p> <ol style="list-style-type: none"> 1) Before drawing out the module, push gliding slab 3, 8 and 13 of CT terminal to “connecting” state; 2) After installing the new module, push gliding slab 3, 8 and 13 of CT terminal to “breaking” state.

To assist customers in simplifying the wiring of current transformers (CTs) when using Sinexcel cabinets, Sinexcel has introduced CT terminal blocks.

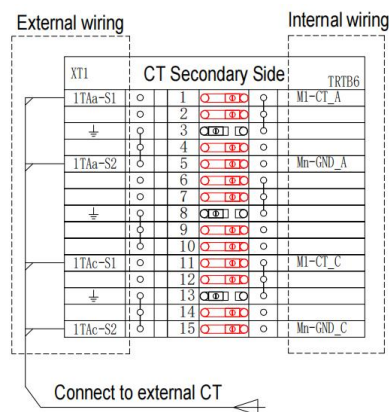

Figure 2- 22 CT terminal structure

CT CONNECTIS ON THE LOAD SIDE

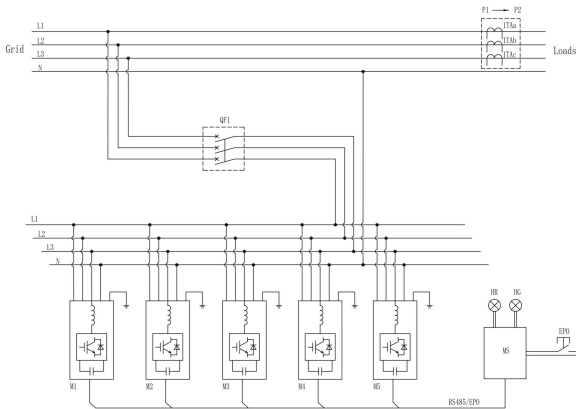

Figure 2- 23 3-Phase 4-Wiring System

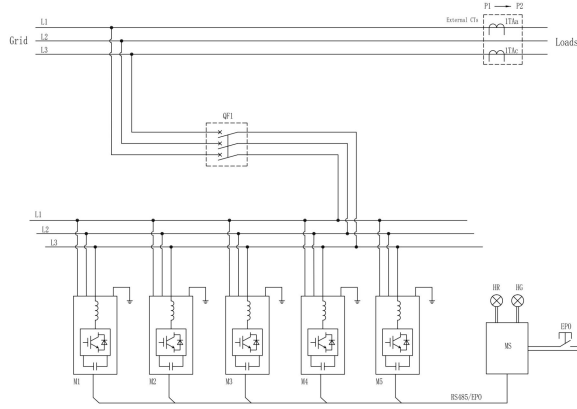

Figure 2- 24 3-Phase 3-Wiring System

CT CONNECTIS ON THE SUPPLY SIDE

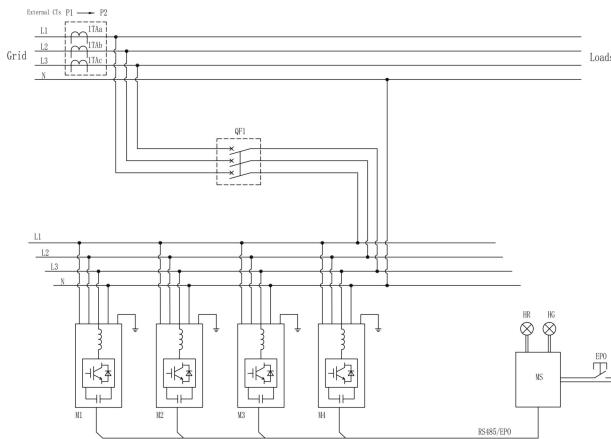

Figure 2- 25 3-Phase 4-Wiring System

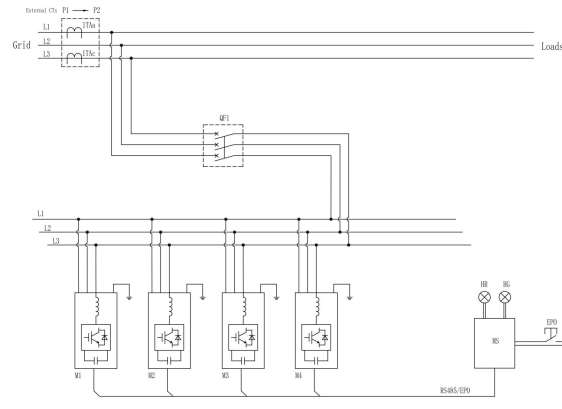

Figure 2- 26 3-Phase 3-Wiring System

Note:

- When user chooses Sinexcel cabinet solution, which for all the wiring between modules will be completed in Sinexcel factory. The only two that user need to connect are external CT and power cables.
- During the maintenance, please follow the below steps.
 - 1) Before pulling out the module, please keep the slider No.3 , 8 and 13 of XT1 short-circuited.
 - 2) After the installation of replaced module, please keep the slider No.3 , 8 and 13 of XT1 disconnected.



Figure 2- 27 Short-circuited

2.5.2 COMMUNICATION CONNECTION

The Sinexcel 7-inch HMI is designed for centralized control of Sinexcel modules, the HMI provides a clear and detailed display of the status and performance of the modules, allowing for easy monitoring and management of the system, which only needs the function that connect the J22 as the module.

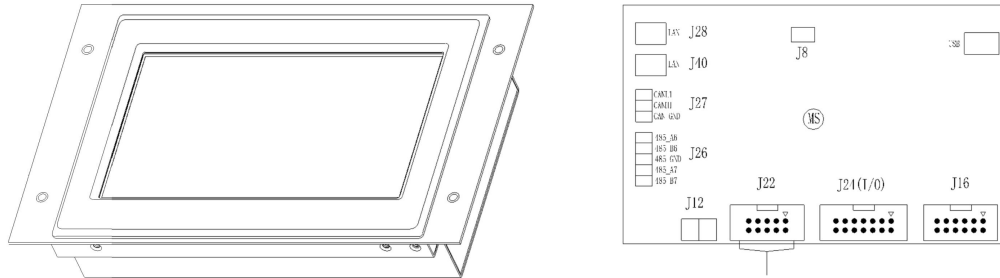

Figure 2- 28 7-inch HMI

Table 2- 6

Length of the cable	3000mm (Standard is 3000mm, but support 5000mm and 10, 000mm length of cable customized; If needs longer cable please contact Sinexcel Engineer)
---------------------	--

Note: The more introduction of Sinexcel 7-inch HMI please refer as Appendix X.

2.5.3 485 COMMUNICATION CABLE

	<p>NOTICE</p> <p>When you parallel the rack mounted modules that need to connect the communication cable, which to meet the communicate between the modules.</p>
--	---

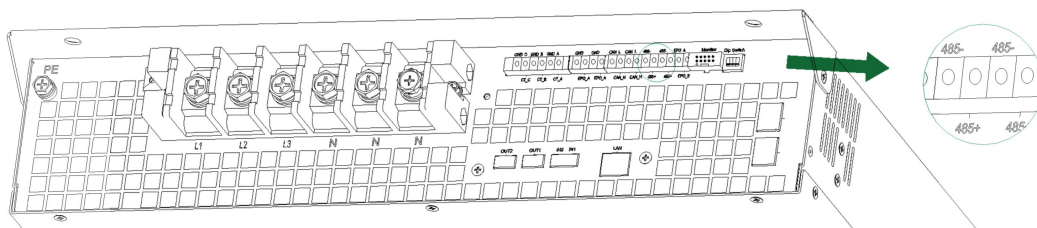



Figure 2- 29 The position of 485

Note: The function of 485, which is to communicate between modules and 7-inch HMI.

2.5.4 CAN COMMUNICATION CABLE



NOTICE

When you parallel the rack mounted modules that need to connect the communication cable, which to meet the communicate between the modules.

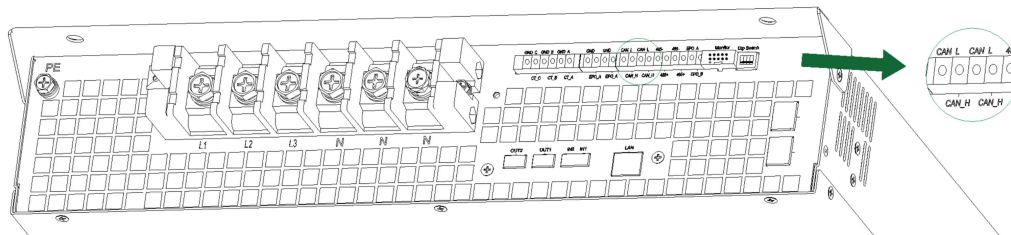

Figure 2- 30 The position of CAN

Note: The function of CAN, which is to communicate between modules.

2.5.5 DIP SWITCH

The dip switch is on the rear side of the module is used when using 7-inch HMI to control rack-mounted LED modules, which to identify the individual modules by giving them an address via the dip switch.

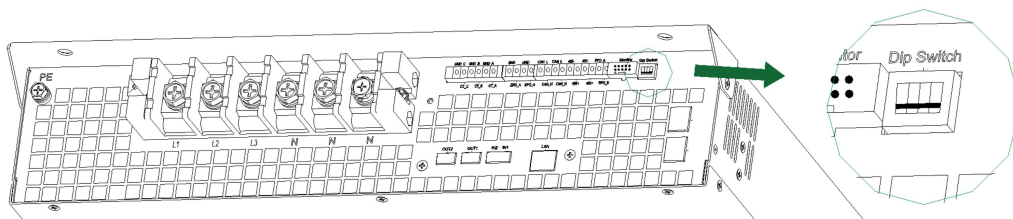

Figure 2- 31 The position of DIP SWITCH

The dip switch is made by CT1, CT2, CT3 and CT4., which are four contacts.

They're two status of the dip switch, 0 and 1.

Table 2- 7 The definition of dip switch

Status	Description
0	When dip switch down, "0" stands for "off"
1	When dip switch up, "1" stands for "on"

The relationship between the dip switch and the machine number is expressed in binary, as shown in Table 2-8 below:

Table 2- 8

CT1	CT2	CT3	CT4	Machine Number		CT1	CT2	CT3	CT4	Machine Number
0	0	0	0	1		0	0	0	1	9
1	0	0	0	2		1	0	0	1	10
0	1	0	0	3		0	1	0	1	11
1	1	0	0	4		1	1	0	1	12
0	0	1	0	5		0	0	1	1	13
1	0	1	0	6		1	0	1	1	14
0	1	1	0	7		0	1	1	1	15
1	1	1	0	8		1	1	1	1	16

For example, if there three 100K SVG rack-mounted connection, which for the dip switch should be:

Table 2- 9 Dip Switch Setting

No.	Dip Switch
The first module	0000
The second module	0001
The third module	0011

CHAPTER III COMMISSIONING

3.1 4.3-INCH HMI INTRODUCTION

For the 4.3-inch HMI, which only support in Sinexcel Ultra wall-mounted module;

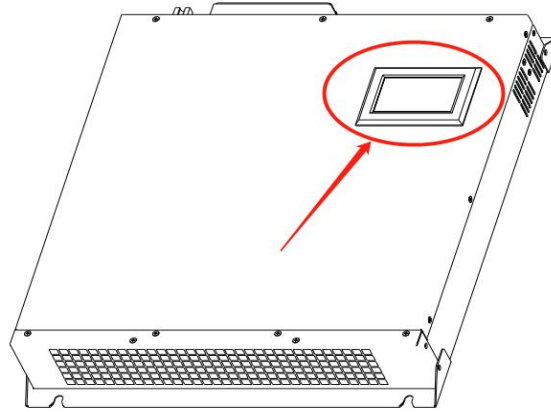

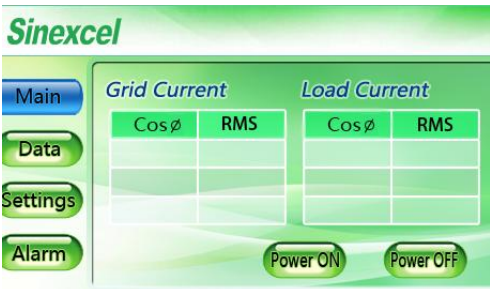
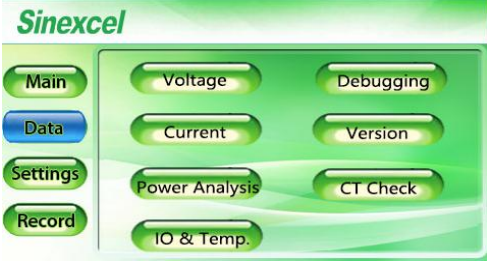
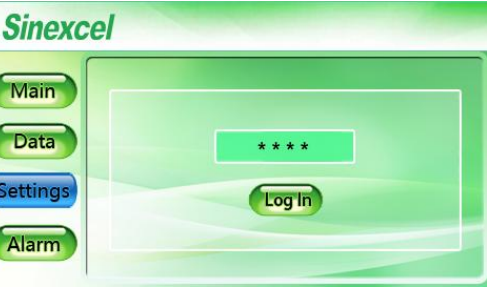



Figure 3- 1 The position of 4.3-inch HMI

	<p>NOTICE</p> <p>Ensure and connections are correct, safe and follow the manufacturer's instructions.</p>
--	--

Sinexcel 4.3-inch HMI is a fully touchscreen, color visualizing and intelligent monitoring system, which is a leading provider of power electronics solutions. It provides real-time monitoring of power distribution systems, helping users to quickly identify and diagnose any issues that may arise.

	<p>When the module connected with power that the HMI will initialize.</p>
	<p>Main Page</p> <p>After initialized, which the HMI shows the 'Grid Current' and 'Load Current' automatically, and shows the value in time;</p>

	<p>Data Page</p> <p>When user chooses the 'Data Page' that Sinexcel HMI shows more power quality data, like 'Voltage', 'Current', 'Power Analysis', 'IO & Temp.', 'Debugging', 'Version' and 'CT Check'</p>
	<p>Setting Page</p> <p>After completing the physical installation, it is necessary to enter the settings interface to configure the parameters. Once the settings are complete, it is important to check the compensation performance of the module.</p>
	<p>Record Page</p> <p>When the module triggers an alarm, Sinexcel 4.3-inch HMI will record and display the information in real-time on the monitor. The specific issue causing the fault will be displayed, making it easier for users to diagnose and resolve the problem. This feature helps to improve the efficiency of power management and reduce downtime caused by equipment failures.</p>

3.1.1 DATA INTERFACE

In the Data interface that can real time online see the data of the Voltage, Current, Power Analysis, IO & Temp., Debugging and Version and CT check.

Click '**Voltage**' option in the data menu that can be real-time see the data of Grid Voltage, Waveform and Spectrum.

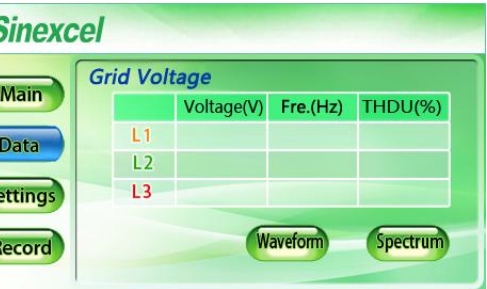
 <p><i>Grid Voltage</i></p>	<p>The 'Grid Voltage' display the data of Voltage(V), Fre.(Hz) and THDu(%) of L1/L2/L3 phase, L1/L2/L3 corresponding to the three phase.</p>
--	---

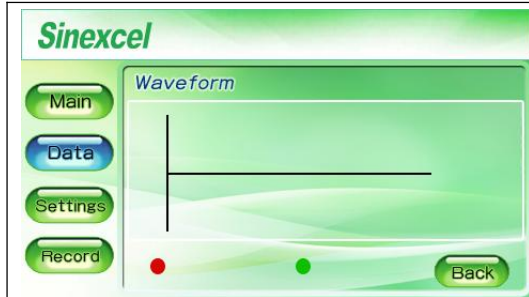

Waveform

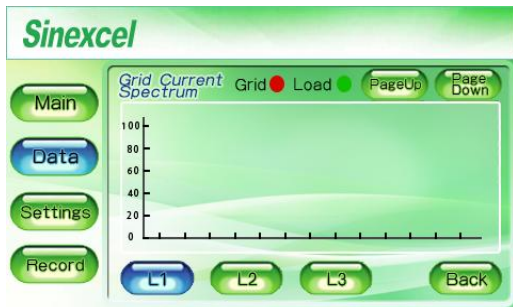

Click the '**Waveform**' on Grid Voltage that can see waveforms of grid voltage and grid current. The red line represents grid voltage, and the green line represents grid current. After watching, click "back" to back to data interface.



Spectrum

Click the '**Spectrum**' on Grid Voltage that can see spectrum of grid voltage and grid current. The red spectrum represents grid harmonic, and the green line represents load harmonic. Click "L1", "L2", "L3", we can see the spectrum of L1 phase, L2 phase and L3 phase respectively.

Click "Page Up" or "Page Down" option to see spectrum with harmonics higher than 13 order or return to interface of harmonic 1 ~ 13 orders. After watching, click "back" option to back to data interface.

Note: Press this button  or  to choose whatever waveform you want show on the display.

Click '**Current**' option in the data menu that can be real-time see the data of Grid Current, Load Current and Comp. Current.

	Current(A)	Cos φ	THDI(%)
L1			
L2			
L3			
Neutral			

Grid Current

The '**Grid Current**' display the data of the Current(A), $\cos\phi$ and THDI (%) of L1/L2/L3 and neutral phase. Also can display Waveform and Spectrum.

	Current(A)	Cos φ	THDI(%)
L1			
L2			
L3			
Neutral			

Load Current

The '**Load Current**' display the data of the Current(A), $\cos\phi$ and THDI (%) of L1/L2/L3 and neutral phase. Also can display Waveform and Spectrum.

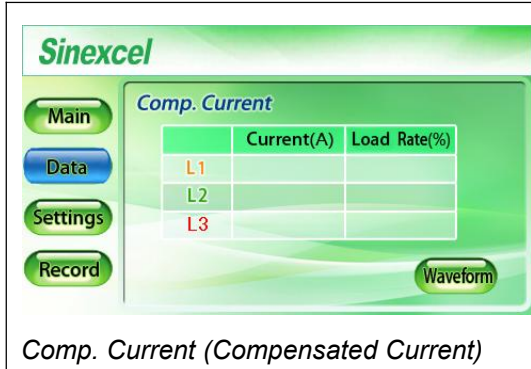

Comp. Current (Compensated Current)

The '**Comp. Current**' display the output Current (A) and Load Rate (%) of L1/L2/L3 phase. Also can display Waveform and Spectrum.

Click '**Power**' option in the data menu that can be real-time see the data of Apparent (KVA), Active (KW), Reactive (KVAr) and PF of Grid L1/L2/L3 and Load L1/L2/L3.

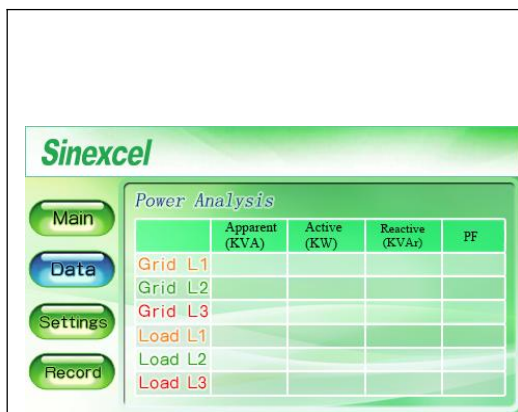

Power Analysis

'Apparent'

The combination of reactive power and true power is called apparent power, and it is the product of a circuit's voltage and current, without reference to phase angle.

'Active'

The power which is actually consumed or utilised in an AC Circuit is called True power or Active power or Real power.'Reactive'

'Reactive'

Reactive power is the resultant power in watts of an AC circuit when the current waveform is out of phase with the waveform of the voltage, usually by 90 degrees if the load is purely reactive, and is the result of either capacitive or inductive loads.

Click '**IO & Temp.**' option in the data menu that can be real-time see the data of IO Status and Temp. (Celsius).

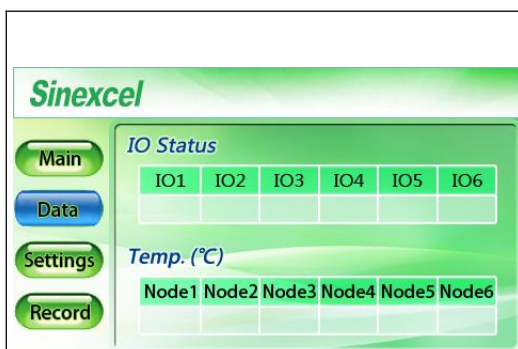

IO & Temp.

The '**IO1~IO6**' are used to monitor IO status information, red means disconnect, green means connected.

The '**Node1~Node6**' are used to monitor machine inter L1/L2/L3 IGBTs temperature, except for the 300A module, which displays six temperature value, other models display the first three values, 'Node4/5/6' are reserved.

Click '**Debugging**' option in the data menu that can be real-time see the data of Analog Address.

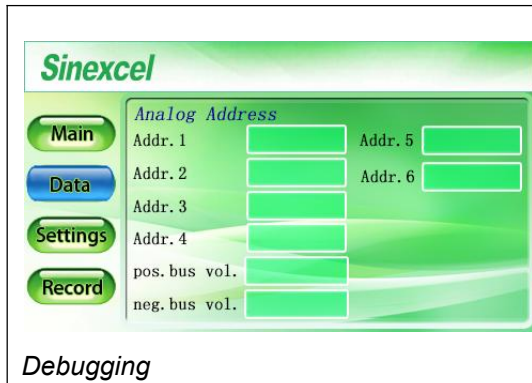

The '**Addr. 1/2/3/4/5/6**' that is used in when the module has some alarms, and need to enter correspond address to check the module operation whether right or not.
 The '**Pos./Neg. bus vol.**' are used to see the value of voltage on different bus.
 The '**Controller Para. P/Q/R**' are used for Sinexcel inter factory test.

Click '**Version**' option in the data menu that can be real-time see the data of Software Version, System Model and Expiry Days.

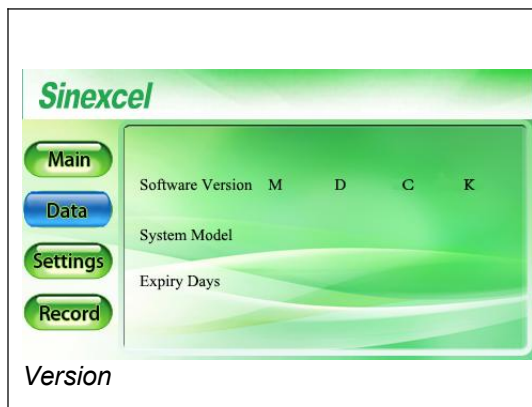

The '**Software Version**' 'M' means the version of monitor, 'D' means the version of U1 board, 'K' and 'T 207' used for R&D of Sinexcel.
 The '**System Model**' refers to the information of the module, includes the type, capacity, wiring and etc. of the module.
 The '**Expiry Days**' refers to the expiry days of the module

Click '**CT Check**' in the data menu that can check the CT wiring well or not.

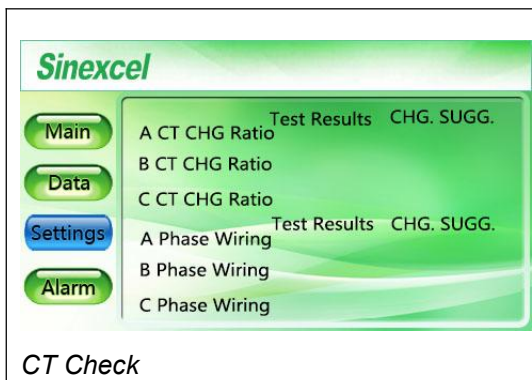

Sinexcel's CT check function is designed to improve the efficiency and convenience of CT installations for customers. CT (current transformer) is an important component in power systems that measures the current flowing through a circuit. However, incorrect installation or malfunctioning of CT can result in inaccurate measurements and potential safety hazards.

3.1.2 PARAMETER SETTING INTRODUCTION

The "General Settings" can be accessed using The '080808' password and is suitable in most applications for system commissioning by the user.

Table 3- 1



General	
Operation Mode	
Power On Mode	
CT Location	
Total Capacity	
NO POW. COMP. 123	
Comp. Mode	
CT Ratio	
Phase Angle Bias	
Target Vol.	
Ext. Passive Filter	
PT Ratio	
THDU Limit	
Unbalanced Limit	
Derating Coeff	



Table 3- 2 Parameter Introduction

Parameter	Meaning and Function of Parameter	Options	Default setting	Unit
Operation Mode	<p>There are 6 working modes applicable to SVG</p> <p>Reactive: Reactive power compensation</p> <p>Q: Reactive power compensation</p> <p>B: Three phase unbalance compensation</p> <p>Auto-aging: The module outputs current according to set compensation rate, which tests whether the module can output normally. (Only factory of Sinexcel testing. User shall be forbidden to use.)</p> <p>Mixed mode: Used for mixed solution, AHF+SVG (Refer to document <One Centralized HMI to Control SVG&SVG Hybrid System> attached for further explanation.)</p> <p>For example: Q+B means reactive power compensation first, then compensate three-phase unbalance compensation.</p>	<p>Reactive</p> <p>Q+B</p> <p>Auto-aging</p> <p>B+Q</p> <p>Balancing</p> <p>Mixed Mode</p>	Reactive	N/A
Power on mode	<p>Manual: It needs to be started by artificial execution in the monitoring interface.</p> <p>Auto: In automatic mode, once the system is connected to power, machine will automatically on and start working.</p>	<p>Manual</p> <p>Auto.</p>	Manual	N/A
CT location	<p>Supply side: CT installation position is closer to the grid transformer side than the power access point of the module.</p> <p>Load side: CT installation position is closer to the load side than the power access point of the module.</p> <p><u><i>Note: If there is LC or capacitor bank in the system, please consult the engineer of Sinexcel and provide single line diagram.</i></u></p>	<p>“Supply side”</p> <p>“Load side”</p>	According to actual condition	N/A
Total Capacity	<p>Total Capacity setting is the total capacity of the system, either single module or combination of multiple modules.</p> <p>The unit is A that for SVG system, need to transfer the kVAr as A; The formula is $P=\sqrt{3} \cdot U \cdot I$</p>	>0	According to actual capacity	Amps
Comp. Mode	<p>Intelligent compensation: Using intelligent Fourier algorithm, the rated capacity can be compensated within five minutes, effectively avoiding resonance.</p> <p>Sequential compensation: Using Fourier algorithm, can quickly compensate the harmonics of the order to rated capacity.</p> <p>All compensation: Quickly compensate all harmonic!!s. (not recommended)</p> <p>The parameter is useless in SVG system;</p>	<p>Intelligent</p> <p>Sequential</p> <p>All</p>	Intelligent compensation	N/A
CT ratio	<p>The setting value need to correspond to the actual ratio of external CT. The secondary of CT only can be 5, the setting range: 50~30000.</p> <p><u><i>Note: ① 500 means 500:5. ② If the CT ratio is 1000:1, then it should be set as “5000”.</i></u></p>	0 ~30000	According to actual condition	Value

Phase Angle Bias	<p>Fundamental wave angle bias calibrate when the compensate performance is not good.</p> <p>The phase angle adjustment needs to be adjusted according to the actual situation on site, normally try from -1~-0.1, then 0.1~1 (accuracy is 0.01), to check whether the compensation effect is better.</p> <p><u>Note: No need to modify, if want to change, please contact with Sinexcel engineer.</u></p>	-180~180	0	°
Target Vol.	<p>This function is connected with Grid Vol. Adjust, if Grid Vol. Adjust function is Disabled, this function is invalid.</p> <p>When the actual phase voltage exceeding the target voltage setting range, the module does the voltage regulation via generating reactive power into the system.</p> <p><u>Note: Please contact engineers of Sinexcel before changing this parameter.</u></p>	220/230	Actual phase voltage	VL-N
Ext. Passive Filter	<p>When SVG works with external passive filters together to compensate for specific harmonic orders only use</p>	3~51	11	Value
PT ratio	<p>When the module is connected to the power grid through a transformer, external transformer ratio should be set.</p> <p>For example: 400V systems the ratio is 1:1 (setting = 1.0);</p> <p>For step-up transformer is 11000V, then set the ratio as 11000/400 = 27.5. (setting=27.5)</p> <p><u>Note: ① Only used in medium and high voltage. ② Consulting Sinexcel engineers before changes are made.</u></p>	0.1~90	1.0	Value
THDU Limit (%)	<p>Module can work under the setting limit of THDU. If THDU exceed the value set by the customer, an alarm will appear in HMI.</p> <p><u>Note: Not used for SVG.</u></p>	0~50	0.0	Value
Unbalanced Limit (%)	<p>Module can work under the setting limit of unbalanced. If unbalanced exceed the value set by the customer an alarm will appear in HMI.</p> <p><u>Note: Not used for SVG.</u></p>	0~1	0.0	Value
Derating Coeff	<p>Limit the biggest output of the module.</p> <p>For example, input 0.9 means the biggest capacity of the machine is 90% of its rated capacity.</p> <p><u>Note: Do not change it without the guidance of Sinexcel engineer.</u></p>	0~1	1.0	Value

3.1.3 RECORD INTRODUCTIONS

Click “Record” on the main menu to enter the record interface.

	<p>Active</p> <p>Sinexcel's monitoring system has a comprehensive alarm function that displays all real-time alarm information in a user-friendly manner. This feature captures and reports critical events such as system faults, voltage abnormalities, communication disruptions, and other related issues. Users can easily customize alarm thresholds and notification settings through the system configuration, ensuring that they receive alerts of significant events without being bombarded with irrelevant information. The monitoring system's intuitive design ensures that users can quickly access and analyze data when a potential issue occurs, promoting proactivity in addressing any performance or efficiency concerns and ultimately reducing downtime and maintenance costs.</p>
	<p>History</p> <p>Sinexcel's historical alarm function in monitoring displays all alarms that have occurred since the system was installed, with a maximum record of 500 alarms. This feature allows users to review past alarms and identify any recurring issues or patterns. It is a useful tool for troubleshooting and improving system performance.</p>
	<p>Operation</p> <p>The operation record function in Sinexcel monitoring system records all the operations performed on the system, making it easy to trace back and review. This feature ensures that all actions taken on the system are documented, providing a comprehensive audit trail for future reference.</p>

3.2 COMMISSIONING STEP WITH 4.3-INCH HMI

There are 4 steps to commissioning Sinexcel Ultra series module.

Step1. Check whether the DC bus voltage is normal.

Step2. (Optional) Check whether the PQ data display in the HMI matching the data in customer's meter, do CT check if needed.

Step3. Check whether the basic setting is correct.

Step4. Power on the module

3.2.1 DC BUS VOLTAGE CHECK INTRODUCTION

After power is supplied to the module, the DC bus capacitor will be charged so DC bus voltage will rise. DC bus voltage is key information to judge whether the key component like IGBT and DC bus capacitor is normal or not.

For 400V voltage class module, when the module is in Stop status, the 'pos. bus vol.' and the 'neg. bus vol.' should be both around 310V (for 480V module should be both around 400V).

If the result shows abnormal data, do not power on the module. Try resupply the power to the module, if there is still abnormal bus voltage, contact Sinexcel product engineer for support.

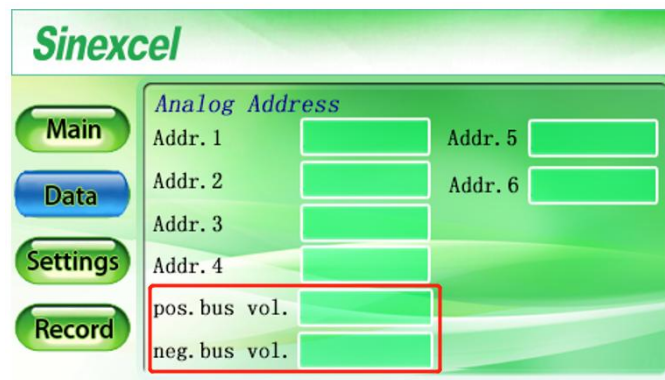

Figure 3- 2 pos/neg. bus vol.

3.2.2 CHECK WHETHER THE DATA IN THE HMI IS MATCHING EXTERNAL METER.

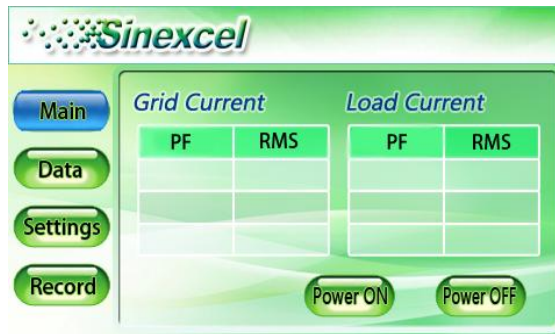

Figure 3- 3 Main page of Ultra SVG

If the data in the HMI is matching external meter, it means the CT wiring probably is correct. The user could use CT auto check function to double check.

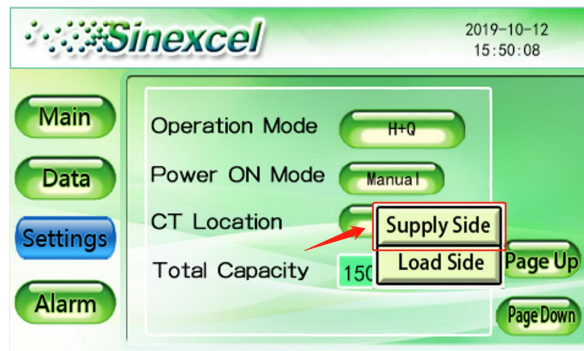

Figure 3- 4 'CT Location'

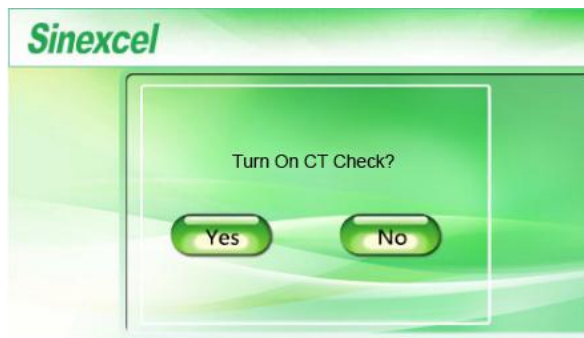

Figure 3- 5 Turn on CT Check

3.2.3 PARAMETER SETTING.

The table below are parameters needed to set up Sinexcel 4.3-inch HMI;

Table 3- 3 Parameter setting in HMI

Operation Mode
Total Capacity
Comp. Rate
Comp. Mode
CT Ratio
Power On Mode
CT Location

Take SVG 100K for example, assuming SVG is used for reactive power compensation, and the CT ratio on site is 300:5. In the case, the parameters should be set to:

Table 3- 4 Case demonstration

Setting	Setting parameters
Operation Mode	Reactive
Total Capacity	150
Comp. Rate	1.0
CT Ratio	300
Power On Mode	Manual or Auto
CT Location	Based on site

3.2 7-INCH HMI INTRODUCTION

Sinexcel 7-inch HMI is typically used to control multiple modules, making management more convenient. It features a full touch screen and a colorful visual display for monitoring.

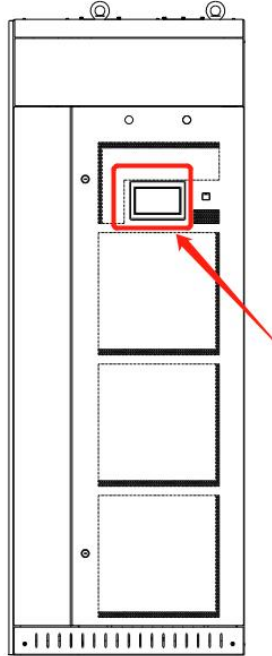
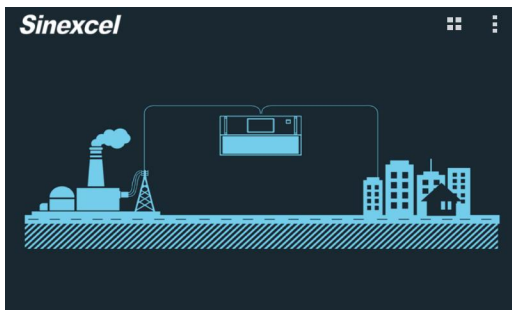

Figure 3- 2 The position of 7-inch HMI



NOTICE

Ensure and connections are correct, safe and follow the manufacturer's instructions.



Main page

When the module connected with power that the HMI will initialize.
In main page, user can see the performance directly.



Main Screen with drop-down selection

There's 7 parts in Sinexcel 7-inch HMI, 'Main', 'Info.', 'Records', 'Settings', 'Help', 'About' and 'Back'

Note: click on  to get a drop-down selection

3.2.1 'INFO' ILLUSTRATE

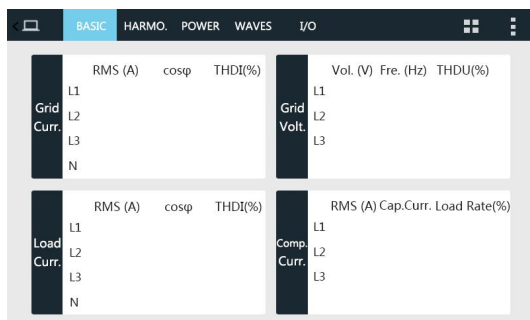

Basic Interface

The '**BASIC**' can be real-time observe the data of RMS(A), PF, THDi(%), Vol.(V), Fre.(Hz) and THDu(%) of Grid Current, Grid Voltage and Load Current, and RMS(A) and Load rate(%) of Compensate Current.

"**Grid Curr.**" means the current after compensation. For example, PF in Grid Curr. refers to the compensated PF value

"**Grid Volt.**" means the voltage of module power access point.

"**Load Curr.**" means the current before compensation. For example, THDi (%) in Load Curr. refers to the before compensated THDi (%) value.

"**Comp Curr.**" means the current outputted from module.

"**RMS**": root mean square of current.

"**Lode Rate**": Ratio of Comp power to rated power of Module.

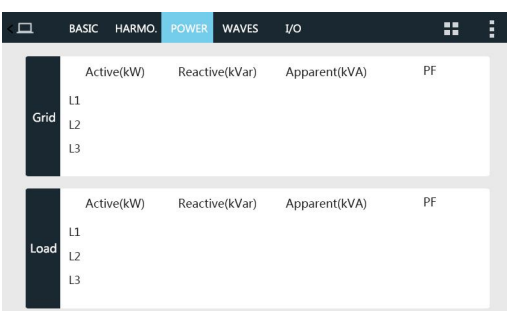

Power

The '**POWER**' can be real-time get the information of Active(kW), Reactive(kW), Apparent(kW) and $\cos\phi$ of Grid side and Load side.

'**Grid side**' means after compensation. For example, $\cos\phi$ in Grid Side refers to the compensated $\cos\phi$ value.

'**Load side**' means before compensation.

Note: This $\cos\phi$ is real PF, not include the reactive power.

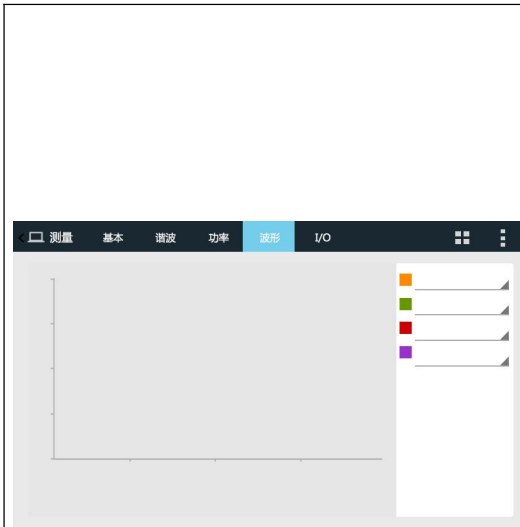

Waves

The 'WAVES' can be real-time see all current and voltage waveform of each phase.

Display four kinds of waveforms, Comp. I L1/L2/L3, Grid I L1/L2/L3, Grid V L1/L2/L3 and Load I L1/L2/L3.



Click  , pop-up menu, select the waveform displayed in the color.

'**Comp. I L1/L2/L3**' refers to the L1/L2/L3 phase compensate current waveform, each time choose one phase.

'**Grid. I L1/L2/L3**' refers to the L1/L2/L3 phase current waveform after compensating, each time choose one phase.

'**Grid. V L1/L2/L3**' refers to the L1/L2/L3 phase voltage waveform after compensating, each time choose one phase.

'**Load. I L1/L2/L3**' refers to the L1/L2/L3 phase current waveform before compensating, each time choose one phase.

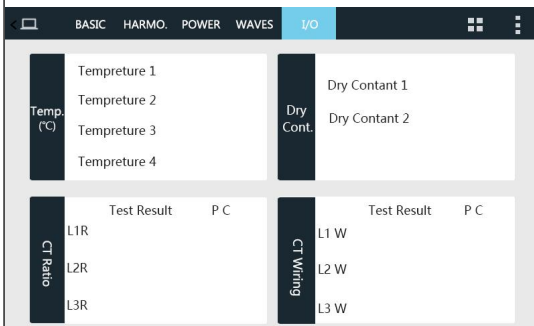

I/O

The 'I/O' can be real-time observe module's inner highest temperature of L1/L2/L3 phase and Air inlet.

'**Temperature 1/2/3**' means module inner highest temperature of L1/L2/L3 phase (dry contact is useless).

'**Temperature 4**' means the temperature of Air inlet.(This function is only for PRO version module)

'**Dry Content 1/2**' means The state of the dry contact is normal when the dry contact board is externally connected.

3.2.2 RECORD INTRODUCTION

Click “**Record**” on the main menu to enter the record interface.

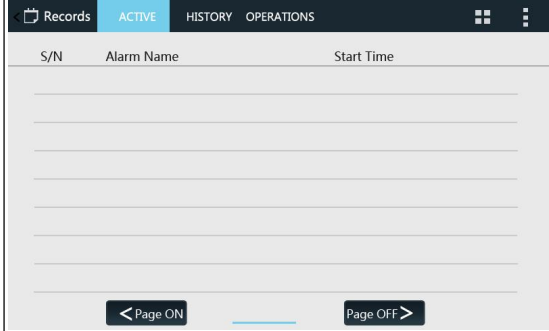
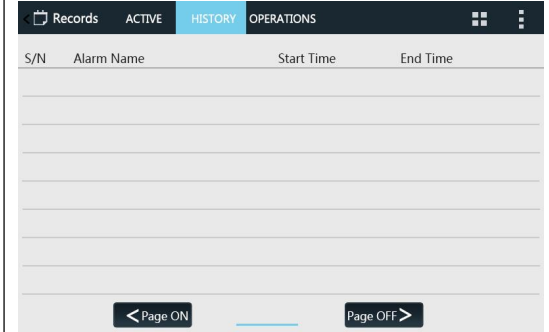
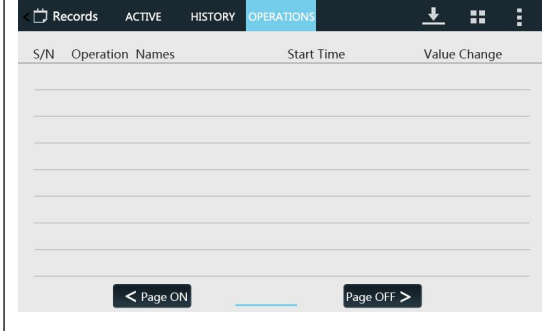
	<p>Active</p> <p>Sinexcel's monitoring system has a comprehensive alarm function that displays all real-time alarm information in a user-friendly manner. This feature captures and reports critical events such as system faults, voltage abnormalities, communication disruptions, and other related issues. Users can easily customize alarm thresholds and notification settings through the system configuration, ensuring that they receive alerts of significant events without being bombarded with irrelevant information. The monitoring system's intuitive design ensures that users can quickly access and analyze data when a potential issue occurs, promoting proactivity in addressing any performance or efficiency concerns and ultimately reducing downtime and maintenance costs.</p>
	<p>History</p> <p>Sinexcel's historical alarm function in monitoring displays all alarms that have occurred since the system was installed, with a maximum record of 500 alarms. This feature allows users to review past alarms and identify any recurring issues or patterns. It is a useful tool for troubleshooting and improving system performance.</p>
	<p>Operation</p> <p>The operation record function in Sinexcel monitoring system records all the operations performed on the system, making it easy to trace back and review. This feature ensures that all actions taken on the system are documented, providing a comprehensive audit trail for future reference.</p>

3.2.3 PARAMETER SETTING INTRODUCTION

	<p>The “General Settings” can be accessed using The '080808' password and is suitable in most applications for system commissioning by the user.</p>
---	---

Table 3- 5

General	
Operation Mode	
Target Power Factor	
Comp. Rate	
Total Capacity	
Comp. Mode	
CT Ratio	
Power On Mode	
Slave Module Quantity	
PT Ratio	
CT Location	
Constant Reactive	
RP Tracking Ctrl Val	

Table 3- 6 Parameter Introduction

Parameter	Meaning and Function of Parameter	Options	Default setting	Unit
Operation Mode	<p>There are 6 working modes applicable to SVG</p> <p>Reactive: Reactive power compensation</p> <p>Q: Reactive power compensation</p> <p>B: Three phase unbalance compensation</p> <p>Auto-aging: The module outputs current according to set compensation rate, which tests whether the module can output normally. (Only factory of Sinexcel testing. User shall be forbidden to use.)</p> <p>Mixed mode: Used for mixed solution, AHF+SVG (Refer to document <One Centralized HMI to Control SVG&SVG Hybrid System> attached for further explanation.)</p> <p>For example: Q+B means reactive power compensation first, then compensate three-phase unbalance compensation.</p>	<p>Reactive</p> <p>Q+B</p> <p>Auto-aging</p> <p>B+Q</p> <p>Balancing</p> <p>Mixed Mode</p>	Reactive	N/A
Target Power Factor	<p>Set the target value of the grid side power factor.</p> <p>The setting range: -1~1.</p>	[-1, 1]	1.0	cosφ
Total Capacity	Total Capacity setting is the total capacity of the system, either single module or combination of multiple modules.	>0	According to actual capacity	Amps
Comp. Mode	<p>Intelligent compensation:</p> <p>Sequential compensation:</p> <p>All compensation: Quickly compensate all harmonic!!!s. (not recommended)</p> <p>Not used for SVG system;</p>	<p>Intelligent</p> <p>Sequential</p> <p>All</p>	Intelligent compensation	N/A
CT ratio	<p>The setting value need to correspond to the actual ratio of external CT. The secondary of CT only can be 5, the setting range: 50~30000.</p> <p>Note: ① 500 means 500:5. ② If the CT ratio is 1000:1, then it should be set as "5000".</p>	0 ~30000	According to actual condition	Value
Power on mode	<p>Manual: It needs to be started by artificial execution in the monitoring interface.</p> <p>Auto: In automatic mode, once the system is connected to power, machine will automatically on and start working.</p>	<p>Manual</p> <p>Auto.</p>	Manual	N/A
Slave module quantity	Setting the total number of modules in parallel, which are controlled by single 7inch HMI.	1~16	The value of the number of parallel modules	Value
PT ratio	<p>When the module is connected to the power grid through a transformer, external transformer ratio should be set.</p> <p>For example: 400V systems the ratio is 1:1 (setting = 1.0);</p> <p>For step-up transformer is 11000V, then set the ratio as 11000/400 = 27.5. (setting=27.5)</p> <p>Note: ① Only used in medium and high voltage. ② Consulting Sinexcel engineers before changes are made.</p>	0.1~90	1.0	Value

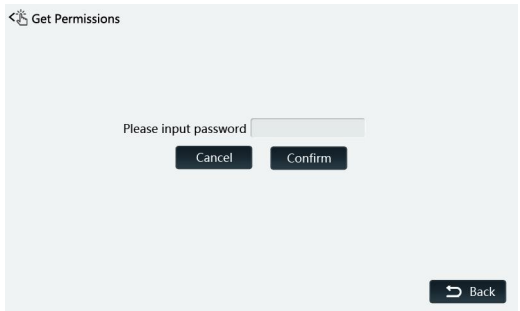
<p>CT location</p>	<p>Source side: CT installation position is closer to the grid transformer side than the power access point of the module.</p> <p>Load side: CT installation position is closer to the load side than the power access point of the module.</p> <p>User can choose source or load side to install CT.</p>	<p>:</p> <p>Source side Load side</p>	<p>According to actual condition</p>	<p>N/A</p>
<p>Temperature derating</p>	<p>Disable: When the overheat protection sensors of the module detect the temperature of IGBTs more than 95°C, the output won't be derated.</p> <p>Enable: The module derating capacity is judged by detecting the IGBT temperature. When the temperature exceeds 95°C and the duration reaches ten minutes, the module will automatically derating 10% of rated capacity. If the temperature still exceeds 95°C and the duration reaches ten minutes, the module will automatically derated 10% capacity based on the capacity of last derated. By analogy, the maximum derating capacity of the module is 50%, but when the temperature is less than 85°C, the module will automatically back to the original rated capacity.</p>  <p>Take SVG 100K as example, when the temperature of the IGBT reach 95°C and lasts 10 minutes, it will reduce 10% capacity, then the SVG capacity is 90K. SVG will detect the temperature again, if the temperature is still rising and lasts time is 10 minutes, it will reduce 10% capacity again, then the SVG capacity is 80K. If temperature reduce to 85°C after derating, the SVG capacity will return to 100K.</p>	<p>Disable Enable</p>	<p>Enable</p>	<p>N/A</p>
<p>Constant reactive</p>	<p>This function could make SVG generate constant reactive power to the grid. No need of CT, because it's output reactive power is constant.</p>	<p>[-3000, 3000] (+) Inductive (-) Capacitive</p>	<p>0.0</p>	<p>kvar</p>
	<p>RP Tracking Ctrl Val means "Reactive Power Tracking Control Value".</p> <p>This parameter can be set to output either a constant inductive or capacitive reactive power into the system, before the system will perform its normal reactive power compensation function, as</p>			

<p>RP Tracking Ctrl. Val</p>	<p>required by the load. This function can be used to compensate for the reactive power generated by the SVG itself or to compensate for magnetising reactive power required by the upstream transformer, typically when the utility meter the client on the primary side of transformer, but SVG system is installed on secondary side. A transformer magnetising current should be inductive, so to compensate for the inductive reactive power, the RP Tracking Ctrl Val should be set to output capacitive reactive power.</p> <p>(Under normal operation, and if value is set at "0.0" the SVG will compensate for the reactive power required by the load. If target for cos phi is set at 0.99 for the LV side, the cos phi might be 0.97 on the MV side where the client is metered. The RP Tracking Ctrl Val setting will allow SVG to output a constant cos phi to compensate for the additional reactive power required by the transformer, before performing its normal Reactive power compensation.) The setting therefore improves the Power Factor at the metered point with lower kVA demand and reactive energy charges.</p> <p>(For example: A value of -7.5 will output 7.5kVAr of Capacitive Reactive Power into the system constantly before the SVG compensate for the reactive power required by the load)</p>	<p>[-3000, 3000]</p> <p>(+) Inductive (-) Capacitive</p>	<p>0.0</p>	<p>kvar</p>
------------------------------	---	--	------------	-------------

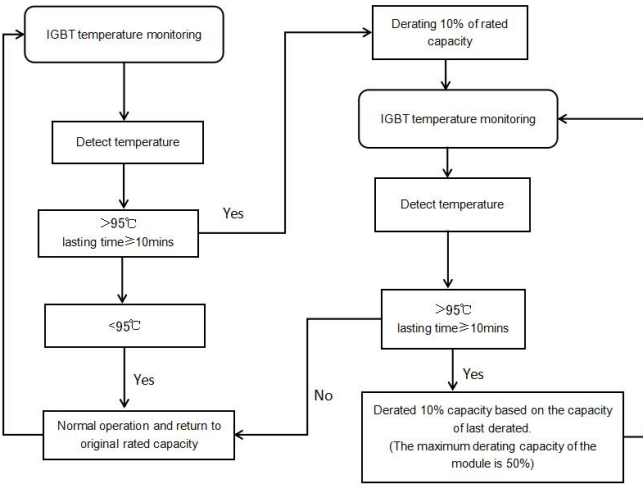
3.2.4 PARAMETER SETTING

The table below are parameters needed to set up Sinexcel 7-inch HMI;

Table 3- 7 Parameter setting in HMI

Operation Mode
Total Capacity
Comp. Rate
Comp. Mode
CT Ratio
Power On Mode
Slave Module Quantity
CT Location

Take one 500K SVG system for example. Assuming this system contains five SVG 100K modules and use 7-inch HMI for monitoring. The CT ratio is 3000:5.

In this case, before module power on, the quick commission should be:

Table 3- 8 Case demonstration

Setting	Setting parameters
Operation Mode	Reactive
Total Capacity	650
Comp. Rate	1.0
Comp. Mode	Intelligent
CT Ratio	3000
Power On Mode	Manual or Auto
Slave Module Quantity	5
CT Location	Based on site

3.2.5 HELP

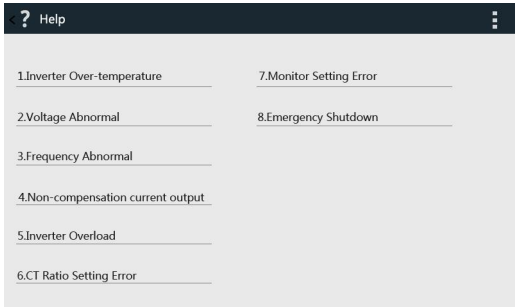
	<p>There are eight common types of alarms, for detailed explanations, please refer to Appendix X.</p>
---	---

3.2.6 ABOUT

	<p>The system software version information</p> <p>For example: Machine Cod 000000 Version M317D000B000 (M: Monitor version, D:DSP version) System Mode 380-0/0-4-0 Expiry Days(d) Forever</p>
---	---

APPENDIX I SINEXCEL ULTRA SVG SPECIFICATION

Items	Sinexcel Ultra Series SVG			
	30K	50K	100K	200K
Rating	30K	50K	100K	200K
Function	Reactive power and three-phase unbalance compensation			
System parameters				
Nominal voltage	380/400/415V (228-456V)			
L-N voltage	220/230/240V (127-263V)			
Nominal frequency	50/60Hz, auto sensing (Range : 45Hz~62.5Hz)			
Parallel quantities	Unlimited			
Efficiency	99%			
Connection type	3 Phase 3 Wire / 3 Phase 4 Wire			
CT location	Load / Supply side			
Performance indicators				
Zero-Sequence compensation rate	3 times capacity compensated, >97%.			
Fast response Time	< 50us			
Full response Time	< 15ms			
Target power factor	Adjustable from -1 to +1			
Switching frequency	Average 40kHz, up to 95kHz			
Cooling air requirement	180CFM	180CFM	240CFM	480CFM
Noise level	<60dB (Full load)	<60dB (Full load)	<65dB (Full load)	<68dB (Full load)
Communications ports	RS485 and Ethernet port (optional)			
Communications protocols	Modbus RTU, TCP/IP (optional)			
Module display interface	4.3-inch HMI(module), 7-inch HMI(centralized monitor) and LED			
Protection functions	Over-voltage protection, under-voltage protection, inverter bridge inverse protection, over-compensation protection and so on			
Dimensions (W x D x H mm)	500*470*88	500*470*88	500*520*100	500*646*220
Net weight	18kg	18kg	25kg	63kg
Storage temperature	-40℃~70℃			
Operating Ambient temperature	-10℃~40℃ (may derate capacity if ambient temperature exceeds 40℃)			
Relative humidity	5% to 95%, non-condensing			
Altitude	≤1500m, 1500-4000m, capacity is derating 1% for every 100m altitude increased.			
Protection class	IP20 (IP grade supports customizable)			

7-INCH INTERFACE & DIMENSIONS

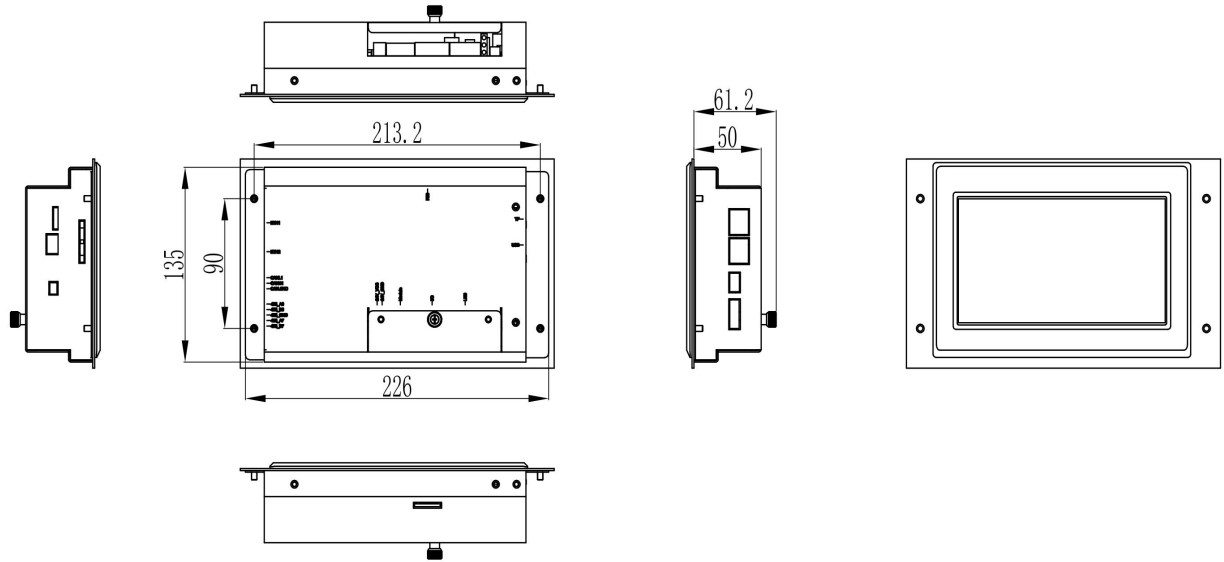

Figure A- 1 Dimensions of Sinexcel 7-inch HMI

Sinexcel 7-inch HMI, which the size is W226*D61.2*H135mm.

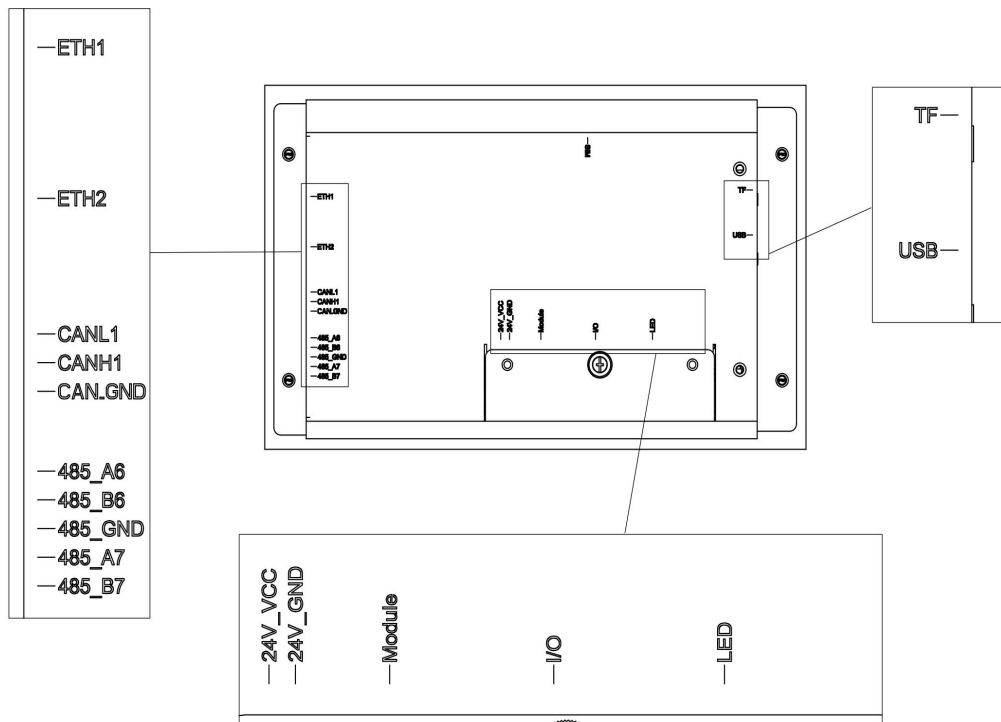

Figure A- 2 Structure of Sinexcel 7-inch HMI

Table A- 2 Introduction of Sinexcel 7-inch HMI

Item	Function	Note
Eth1	Used as Ethernet communication	Optional
Eth2		
CAN_L1	Used as CAN communication	
CAN_H1		
CAN_GND		
485_A6	Used as 485 communication	
485_B6		
485_GND		
485_A7		
485_B7		
24V_VCC	24V DC power supply (+)	
24V_GND	24V DC power supply (-)	
MODULE	Used as connecting with SVG module	The module supplies power to the HMI through this port, eliminating the need for a 24V power supply
I/O	Used as dry connect to power on/off module remotely and see the status of module	
LED	Used as connecting with RUN LED/ALARM LED/EPO button	
USB	Used as upgrading the software of HMI CPU via USB drive	
TF	Used as upgrading the software of HMI screen via micro SD	
SIM		

SINEXCEL 7-INCH HMI RECORDING AND DOWNLOAD FUNCTION

The data recording and downloading function of Sinexcel Electric 7inch HMI, which can be accessed from two interfaces. The first part shows the data recorded automatically by HMI, mainly historical alarms and data, and the other interface is the data and setting information collected manually by users.

01 Records Download

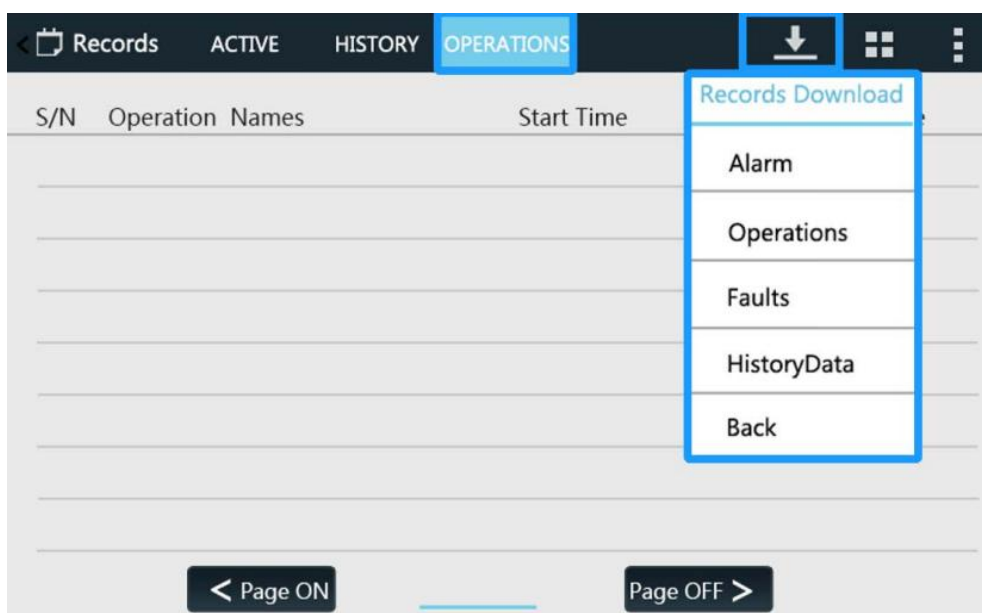

Figure A- 3 Sinexcel 7-inch HMI Records Download

Sinexcel

Alarms, Operations, Faults, History data

Alarm records (historical equipment alarm information) and operation records (historical manual setting records) can be exported 500 records each.

Fault point information: HMI automatically record module's fault information for Sinexcel R&D analysis (including hardware and software faults: inverter, relay, capacitor, hall, soft start, auxiliary power supply, etc.; Info includes load current/compensation current/positive and negative bus voltage/temperature, etc.)

Historical data: HMI automatically record 20, 000 analog data (analog data include: L1/L2/L3 three-phase grid current, three-phase grid voltage, three-phase grid THDI, three-phase grid THDV, three-phase grid PF, three phase grid frequency, three-phase grid active/reactive/ apparent power; L1/L2/L3 three-phase load current, three-phase load voltage, three-phase load THDI, three-phase load THDV, three-phase load PF, three-phase load frequency; L1/L2/L3 three-phase compensation current, three-phase compensation load rate, temperature, etc.) , record more than 20, 000 new data collected by monitoring and automatically overwrite old data.

02 Data Record & Export

When customers need to record system grid current, voltage, power factor, and other data and monitoring settings, information can be collected and exported through the following monitoring interface.

Step 1: Setting-PREFER.-Data Record

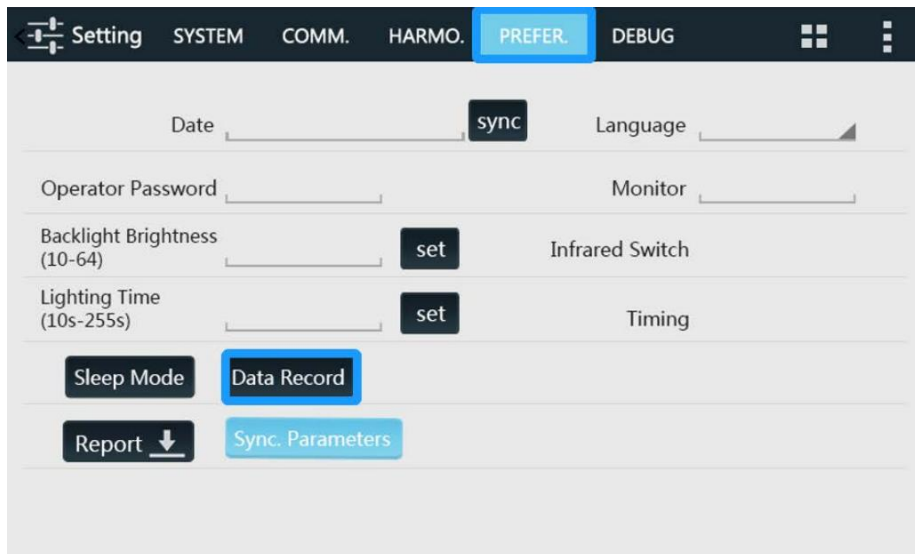

Figure A- 4 Sinexcel 7-inch HMI Setting-PREFER.-Data Record

Step 2: Data Record-Start Recording

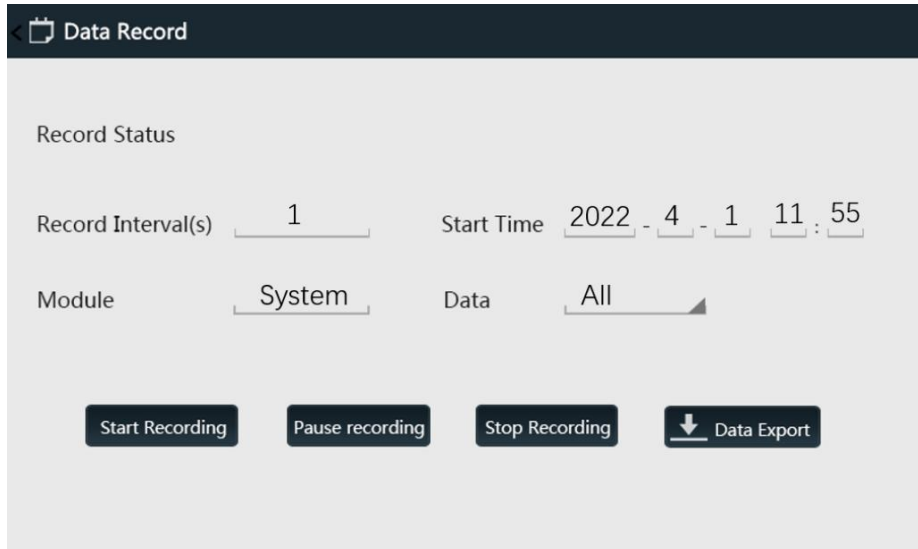

Figure A- 5 Sinexcel 7-inch HMI Data Record-Start Recording

Record Interval(s): 1 (1 second, default setting)

Setting range: 1~70 (1 second to 70 seconds record interval), can be manually set by the customer. The minimum interval time is 1 second, the maximum interval time is 70 seconds to record a record. A total of 8,640 pieces of data will be recorded. If the record interval set as 1, then it takes 2.4hours to complete the recording. If the record interval set as 10, then it takes 24hours to complete the recording. If the record interval set as 70, then it can record the data for one week.

The recording data will be stored in the HMI, the previous data will be overwritten after the next recording is restarted

Start Time: It can be set manually by the customer, and the current time will be displayed by default. Customers can choose to start data collection from the current time, or set a specific collection demand time.

Module: Module (# 1~ #16)/System, can select records for individual modules or data records for the entire system.

Data: All/Only Analog/Only Setting; "All": including analog data and setting parameters

Data recorded can be classified into two categories: analog (current, voltage, PF, THDI, etc.) and setting parameters.

Analog data include: L1/L2/L3 three-phase grid current, three-phase grid voltage, three-phase grid THDI, three-phase grid THDV, three-phase grid PF, three phase grid frequency, three-phase grid active/reactive/apparent power; L1/L2/L3 three-phase load current, three-phase load voltage, three-phase load THDI, three-phase load THDV, three-phase load PF, three-phase load frequency; L1/L2/L3 three-phase compensation current, three-phase compensation load rate, temperature, etc.

Setting parameters include: all settings accessible with 080808 password (operation mode, target power factor, compensation rate, total capacity, CT transformation ratio, phase angle offset, etc.).



Figure A- 6 Sinexcel 7-inch HMI Data Record Setting

Step 3: Insert the USB into the HMI

Insert the USB flash drive on the side of the monitor.

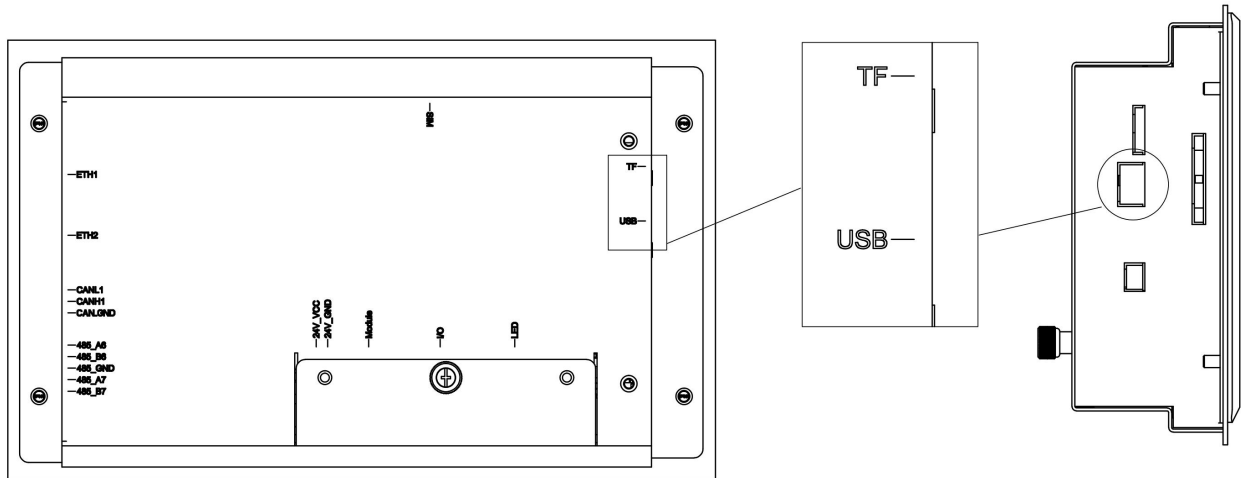

Figure A- 7 Sinexcel 7-inch HMI USB Port

Start Recording, Pause Recording, Stop Recording, Data Export

Click “Start Recording” , then the HMI will start recording the data of certain module or the entire system. Recording start time can be preset via the interface, click "Start Recording" to start recording, customers can temporarily stop recording or directly terminate data recording.

Step 4: Data Export

Data record is presented in the form of Excel table, which can be exported by U disk.

Click "Export Data" to save the corresponding data in the USB flash drive in Excel format. After exporting the data, the monitoring will automatically clear the stored data in the register.



Figure A- 8 Sinexcel 7-inch HMI PO Record Data

ID	RecordTime	CommState	Module	Grid	Curr.	LGrid	Curr.	Grid	Curr.	Grid	Curr.	Grid	Curr.	Grid	Curr.	Grid	Curr.	Grid	Curr.	Grid	Curr.	Grid	Volt.	
1	2022-04-01	2	0	0	0	0	0	0	0	1	1	-1	130.1	124	125.5	0.1								
2	2022-04-01	2	0	0	0	0	0	0	0	1	1	-1	130.1	124	125.5	0.1								
3	2022-04-01	2	0	0	0	0	0	0	0	1	1	-1	130.1	124	125.5	0.1								
4	2022-04-01	2	0	0	0	0	0	0	0	1	1	-1	130.1	124	125.5	0.1								
5	2022-04-01	2	0	0	0	0	0	0	0	1	1	-1	130.1	124	125.5	0.1								
6	2022-04-01	2	0	0	0	0	0	0	0	1	1	-1	130.1	124	125.5	0.1								
7	2022-04-01	2	0	0	0	0	0	0	0	1	1	-1	130.1	124	125.5	0.1								
8	2022-04-01	2	0	0	0	0	0	0	0	1	1	-1	130.1	124	125.5	0.1								
9	2022-04-01	2	0	0	0	0	0	0	0	1	1	-1	130.1	124	125.5	0.1								
10	2022-04-01	2	0	0	0	0	0	0	0	1	1	-1	130.1	124	125.5	0.1								
11	2022-04-01	2	0	0	0	0	0	0	0	1	1	-1	130.1	124	125.5	0.1								

Figure A- 9 Sinexcel 7-inch HMI Data Export

SINEXCEL HMI HOLIDAY FUNCTION

The power saving function can help user manage the working day and hour of the module according to the specific requirement of the site.

Another mode is energy saving shutdown mode, it could be set to power off the module when the load rate of the SVG is lower than certain percentage.

- Click 'timing' to enable the power saving function.
- Enter the power on time and power off time.

Note: the power on and time power off time cannot be set to 0:0 at the same time, or this weekday and holiday function will not work.

- Select the week day. Only during the weekday, the module can be power on automatically.
- Select the holiday date. During the holiday, the module cannot be the power on automatically.

Another mode is en also it could be set to power off the module when the load rate of the SVG is lower than some percentage.

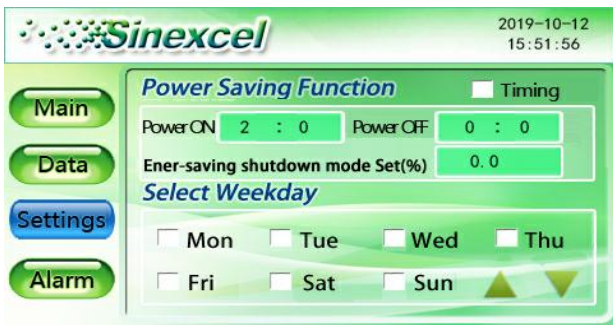
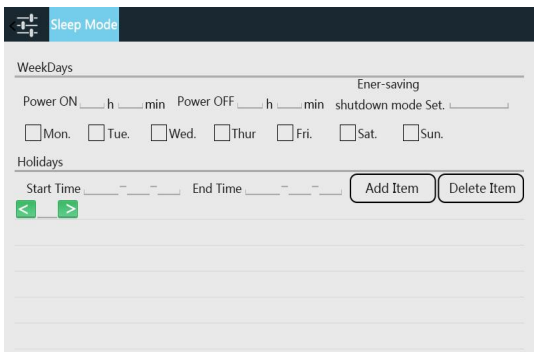
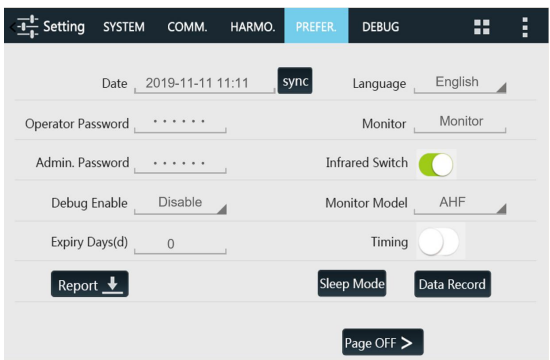
Sinexcel 4.3-inch HMI	Sinexcel 7-inch HMI
	
	

SINEXCEL 7-INCH HMI HIGHER LEVEL PASSWORD PARAMETER INTRODUCTION

Table A- 3 Sinexcel 7-inch HMI higher level password parameter introduction

Parameter	Meaning and Function of Parameter	Options	Default setting	Unit
Capacitive Comp.	<p>This function is not used for SVG; it can realize capacitive reactive power compensation.</p> <p>Enable: then module can do bi-directional reactive power compensation;</p> <p>Disable: Module can only do inductive reactive power compensation</p>	<p>Enable</p> <p>Disable</p>	Enable	N/A
LVRT	<p>LVRT: Low Voltage Ride Through</p> <p>Enable: If supply voltage drops below 90% of voltage lower limit for more than 2s that module will stop working.</p> <p>Disable: The module only works in its entire voltage tolerance range. Once lower than voltage limit, module will stop working.</p> <p>For example, SVG 400V (It's voltage range is 228~456V) that means when you choose "Enable" to work, when the voltage drops the voltage lower voltage(228V) 90%(below 205, 2V), the time lasts 2s or more, the SVG will stop working automatically, but within 205, 2V, the SVG still working.</p> <p>If "Disable" is selected, the SVG will stop working when the voltage reaches the lower limit (228V).</p> <p><u>Note: ① The voltage lower the compensation performance will be worse. ②Please contact engineer of Sinexcel before changing this parameter.</u></p>	<p>Enable</p> <p>Disable</p>	Disable	N/A
Grid Vol. Adjust	<p>This function is not used for SVG.</p> <p>Grid Voltage Adjust is bind with Target Voltage and Voltage Upper/Lower Limit (%). If Grid Voltage Adjust function is Disabled, the settings for the upper voltage and lower voltage limit are invalid.</p> <p>Set the voltage target value. When the system voltage falls below or exceeds the target voltage range, the machine outputs reactive or perceived power to compensate the voltage.</p> <p>Used with "Target Vol", "Vol. Upper Limit (%)", "Vol. Lower Limit (%)" settings. In order to stable the system voltage within certain range by outputting inductive/capacitive reactive power; this function is not commonly used, if there're sites the voltage fluctuates when there's big motor's starting, then we can configure with SVG to regulate the voltage.</p> <p><u>Note: Please contact engineer of Sinexcel before changing this parameter.</u></p>	<p>Enable</p> <p>Disable</p>	Disable	N/A

Target Vol.	<p>This function is connected with Grid Vol. Adjust, if Grid Vol. Adjust function is Disabled, this function is invalid.</p> <p>When the actual phase voltage exceeding the target voltage setting range, the module does the voltage regulation via generating reactive power into the system.</p> <p><u>Note: Please contact engineers of Sinexcel before changing this parameter.</u></p>	220/230	Actual phase voltage	V _{L-N}
Voltage Class	<p>Input actual rate voltage. Set as actual rate voltage of module.</p> <p><u>Note: Not every machine has these voltage options, please refer to the product specifications for details.</u></p>	380/400/ 415 440/480 660/690 1140 208/220 600	According to actual condition	V Actual rate voltage
Freq Range	<p>Input frequency. Set as the actual rated frequency of the module.</p> <p><u>Note: when the system frequency is out of range, the module will give alarm and automatically switch off.</u></p>	50/60	50Hz	Hz
PLL	<p>PLL: Phase-Locked Loop</p> <p>Lock the phase angle of the grid and default enabling.</p> <p><u>Note: Do not change it without the guidance of Sinexcel engineer.</u></p>	Enable Disable	Enable	N/A
Ext. Passive Filter	<p>When AHF works with external passive filters together to compensate for specific harmonic orders only use</p>	3~51	11	Value
DYN11/DYN12/ YYN	<p>When the module is connected to the system by a transformer, select the actual type of transformer.</p> <p>Currently, the module supports 4 types of transformers.</p>	DYN11 DYN12 DYN5 YYN	YYN	N/A
Input Current Abnormal	<p>Enable: The equipment will give an alarm and stop outputting current when its input-current goes wrong.</p> <p>Disable: The equipment will keep outputting current when its input-current goes wrong.</p> <p>For this function, it can prompt the engineer whether there is resonance. If the abnormal current alarm occurs, the machine can return to normal within a few seconds. However, if three consecutive abnormal current alarms occur within three minutes, the alarm needs to be manually cleared before the machine can continue to operate normally, otherwise the machine will remain in the alarm state</p> <p><u>Note: Do not change it without the guidance of Sinexcel engineer.</u></p>	Enable Disable	Enable	N/A

CT Secondary Correct	<p>This setting requires that the connection mode between the CT signal interface and the module be set as "serial" or "parallel".</p> <p>It is recommended that CT signal interfaces between modules be connected in series. Series connections will allow all modules to see the same current for compensation.</p>	Series Parallel	Series	N/A
L1/L2/L3_load_THDI_config.	<p>When the load THDI of L1/L2/L3 phase shown in the HMI is different with the load THDI of L1/L2/L3 phase measured by the power quality detector.</p> <p>Coefficient = Actual load THDI of L1/L2/L3 phase value on power quality detector / Load THDI of L1/L2/L3 phase value on HMI.</p>	>0	1.0	Value
L1/L2/L3_grid_THDU_config.	<p>When the Grid THDU of L1/L2/L3 phase shown in the HMI is different with the Grid THDU of L1/L2/L3 phase measured by the power quality detector.</p> <p>Coefficient = Actual Grid THDU of L1/L2/L3 phase value on power quality detector / Grid THDU of L1/L2/L3 phase value on HMI.</p>	>0	1.0	Value
L1/L2/L3_grid_THDI_config.	<p>For factory HMI calibration, customer is forbidden to change it.</p> <p>Only when the customer has to replace a 4.3inch HMI, then the customer may have to re-calibrate these settings by themselves if they do not keep a record of the calibration data before.</p> <p>Eg. If the external power quality analyzer shows the grid THDI is 10%, while Sinexcel HMI shows 12%, you can change the setting of "L1/L2/L3_grid_THDI_config." to 10/12=0.83 to calibrate Sinexcel HMI.</p>	>0	1.0	Value
Ener-saving shutdown mode set.	<p>The module will power off automatically when the load rate is lower than certain value.</p> <p>For this function has a return difference logic that means when the load rate more than the sum of current load rate you set and return difference value (the value is 3), the machine will power on automatically.</p> <p>Eg. Set as "10", that means when the load ratio is less than 13%, the module will automatically switch "off", only when the load ratio is equal to or above 13%, the module will automatically switch "on".</p> <p><i>Note: 0 means mode is switched "off" or disabled.</i></p>	0~100	0.0	Value
Fan gear	<p>It is for maximum speed adjusted of fan.</p> <p>1 is 100% speed, 0.9 is 90% speed.</p> <p>Generally, this setting is not changed, but when the customer feels that the machine is noisy, you can contact the engineer of Sinexcel to adjust it.</p>	0.5~1	1.0	Value
Network Config.	Setting the network structure of the module. It must be same as the actual structure of system.	3P3W 3P4W	According to actual condition	N/A

THDU Limited (%)	<p>Functions designed for Marine application.</p> <p>Connected with the options of “Marine Filter” mode, only when “Marine Filter” mode is Enabled, this function can be used.</p> <p>Module can work under the setting limit of THDU. If THDU exceed the value set by the customer, an alarm will appear in HMI.</p> <p><u>Note: This setting is designed for marine application requirement, no use in common scenes. Not used for SVG system;</u></p>	0~15%	0.0	Value
Unbalanced Limit (%)	<p>Functions designed for Marine application.</p> <p>Connected with the options of “Marine Filter” mode, only when “Marine Filter” mode is Enabled, this function can be used.</p> <p><u>Note: This setting is designed for marine application requirement, no use in common scenes. Not used for SVG system;</u></p>	0~15%	0.0	Value
Derating Factor	<p>Limit the biggest output of the machine.</p> <p>For example, input 0.9 means the biggest capacity of the machine is 90% of its rated capacity.</p> <p><u>Note: Do not change it without the guidance of Sinexcel engineer.</u></p>	0~1	1.0	Value
Test Mode	<p>Only used by R&D of Sinexcel</p> <p><u>Note: Prohibit change.</u></p>	Enable Disable	Disable	N/A
Marine Filter	<p>Used for Marine situation.</p> <p>Connected with THDU Limited (%) and Unbalanced Limit (%), which need be set when Enable this function.</p> <p><u>Note: Not used for SVG system;</u></p>	Enable Disable	Disable	N/A
Allowed Over Temp.	<p>For standard 400V modules, when the IGBT temperature is higher than 100℃, the module will give an “over-temperature” alarm and powered off automatically, and when the temperature is less than 60℃ and lasts for 5mins, the module will automatically on.</p> <p>For some applications, the customer does not want the module power on automatically when it's cooling down, they claim if the alarm is given repeatedly, manual operation will be required.</p> <p>“3” means if the module is given “over-temperature” alarm three times within 24hours, the module will not automatically on even when the temperature is less than 60℃ and lasts for 5mins.</p>	1-10	3	Value
Controller Algorithm	<p>Reserved functions, temporarily closed.</p> <p>In the past it's for R&D only, will be deleted from the interface.</p>	Enable Disable	Disable	N/A
Vol. Upper Limit (%)	<p>Connected with Grid Vol. Adjust, which can only be used if “Grid Vol. Adjust” is Enabled.</p> <p>Set the voltage upper limit. When the system voltage is above the voltage limit, the machine will compensate the voltage.</p>	0~20 (%)	7	Value (%)

Sinexcel

Vol. Lower Limit (%)	<p>Connected with Grid Vol. Adjust, which can only be used if "Grid Vol. Adjust" is Enabled.</p> <p>Set the voltage lower limit. When the system voltage is below the voltage limit, the machine will compensate the voltage.</p>	-20~0 (%)	-10	Value (%)
L1/L2/L3 phase _angle_bias	<p>The setting here refers to the phase angle adjustment of the output compensated current to achieve the consistency between the phase Angle of the compensated current and the phase angle of the required compensation current and achieve better compensation effect.</p> <p>The phase angle adjustment needs to be adjusted according to the actual situation on site, normally try from -1~-0.1, then 0.1~1 (accuracy is 0.01), to check whether the compensation effect is better.</p> <p><u><i>Note: No need to modify, if want to change, please contact with Sinexcel engineer.</i></u></p>	-180~180	0	°

Table A- 4 Sinexcel 4.3-inch HMI higher level password parameter introduction

Parameter	Meaning and Function of Parameter	Options	Default setting	Unit
Network Config.	Set the network structure of module. It should be same as the actual network structure of system.	3P3W 3P4W	According to customer need	N/A
Voltage Class	Input actual rate voltage. Set as actual rate voltage of module. <i>Note: Not every machine has these voltage options, please refer to the product specifications for details.</i>	380/400/ 415 440/480 660/690 1140 208/220 600	According to actual condition	V _{Actual rate voltage}
RP Tracking Ctrl. Val	RP Tracking Ctrl Val means "Reactive Power Tracking Control Value". This parameter can be set to output either a constant inductive or capacitive reactive power into the system, before the system will perform its normal reactive power compensation function, as required by the load. This function can be used to compensate for the reactive power generated by the SVG itself or to compensate for magnetising reactive power required by the upstream transformer, typically when the utility meter the client on the primary side of transformer, but SVG system is installed on secondary side. A transformer magnetising current should be inductive, so to compensate for the inductive reactive power, the RP Tracking Ctrl Val should be set to output capacitive reactive power. (Under normal operation, and if value is set at "0.0" the SVG will compensate for the reactive power required by the load. If target for cos phi is set at 0.99 for the LV side, the cos phi might be 0.97 on the MV side where the client is metered. The RP Tracking Ctrl Val setting will allow SVG to output a constant cos phi to compensate for the additional reactive power required by the transformer, before performing its normal Reactive power compensation.) The setting therefore improves the Power Factor at the metered point with lower kVA demand and reactive energy charges. (For example: A value of -7.5 will output 7.5kVAr of Capacitive Reactive Power into the system constantly before the SVG compensate for the reactive power required by the load)	[-3000, 3000] (+) Inductive (-) Capacitive	0.0	kvar
Allowed Over Temp.	For standard 400V modules, when the IGBT temperature is higher than 100°C, the module will give an "over-temperature" alarm and powered off automatically, and when the temperature is less than 60°C and lasts for 5mins, the module will automatically on. For some applications, the customer does not want the module power on automatically when it's cooling down, they claim if the alarm is given repeatedly, manual operation will be required.	1-10	3	Value

Sinexcel

	“3” means if the module is given “over-temperature” alarm three times within 24hours, the module will not automatically on even when the temperature is less than 60℃and lasts for 5mins.			
Controller Parameter	Reserved functions, temporarily closed. <i>Note: In the past it's for R&D only, will be deleted from the interface.</i>	Enable Disable	Disable	N/A
Variable 1/2/3/4/5/6	Different setting values correspond to different internal variables of DS. <i>Note: Prohibit change.</i>	>0	0	Value
Test Mode	Only used by R&D of Sinexcel <i>Note: Prohibit change.</i>	Enable Disable	Disable	N/A
Hybrid Parameter	Optimize the problem that the voltage zero-cross compensation effect is not good. Can set two parameters: 38 and 40, 38 is closed, 40 is open <i>Note: Prohibit change.</i>	38 40	40	Value
Slave module quantity	Setting the total number of modules in parallel, which are controlled by single 7inch HMI.	1~16	The value of the number of parallel modules	Value
Controller Algorithm	Reserved functions, temporarily closed. In the past it's for R&D only, will be deleted from the interface.	Enable Disable	Disable	N/A
Apparent capacity (kva)	Transformer parameter. <i>Note: Do not change it without the guidance of Sinexcel engineer.</i>	>0	2000	Value
ULL	Transformer parameter. <i>Note: Do not change it without the guidance of Sinexcel engineer.</i>	>0	400	Value
Rated frequency	Transformer parameter. <i>Note: Do not change it without the guidance of Sinexcel engineer.</i>	>0	50	Value
Short circuit impedance uk(%)	For PRO modules No-CT technology <i>Note: Do not change it without the guidance of Sinexcel engineer.</i>	>0	6	Value
Control bandwidth	For PRO modules No-CT technology <i>Note: Do not change it without the guidance of Sinexcel engineer.</i>	>0	0.1	Value
Oscilloscope enable	For PRO modules No-CT technology <i>Note: Do not change it without the guidance of Sinexcel engineer.</i>	>0	Disable	N/A
L1/L2/L3 Inductor Cur.Config.	It is used to calibrate the machine output curret value.In the auto-aging mode , choose inductive current or capacitive current output, then take a average. <i>Note: Prohibit change.</i>	>0	0.0	Value
L1/L2/L3 CT Current Config.	Make the load current that is sampled by the main control DSP corresponds to the actual load current by calibration. <i>Note: Prohibit change.</i>	>0	0.0	Value

L1/L2/L3 Inverter Current Config.	Make the actual current of the inverter corresponds to the DSP value given by calibration. <i>Note: Prohibit change.</i>	>0	0.0	Value
L1/L2/L3 Input Voltage Config.	Make the grid voltage value that is sampled by the main control DSP corresponds to the actual grid voltage by calibration. <i>Note: Prohibit change.</i>	>0	0.0	Value
Input Fre. Rank	Setting the input-frequency of equipment. The value should correspond to actual system frequency. 50Hz/60Hz are available.	50HZ 60HZ	50HZ	N/A
PLL	PLL: Phase-Locked Loop Lock the phase angle of the grid and default enabling. <i>Note: Do not change it without the guidance of Sinexcel engineer.</i>	Enable Disable	Enable	N/A
Input Curr. Abnormal	Enable: The equipment will give an alarm and stop outputting current when its input-current goes wrong. Disable: The equipment will keep outputting current when its input-current goes wrong. For this function, it can prompt the engineer whether there is resonance. If the abnormal current alarm occurs, the machine can return to normal within a few seconds. However, if three consecutive abnormal current alarms occur within three minutes, the alarm needs to be manually cleared before the machine can continue to operate normally, otherwise the machine will remain in the alarm state <i>Note: Do not change it without the guidance of Sinexcel engineer.</i>	Enable Disable	Enable	N/A
DYN11/ DYN12/YYN	The setting value should correspond to actual connecting value of the external transformer which connected between module and grid. <i>Note: Do not change it without the guidance of Sinexcel engineer.</i>	YYN DYN11 DYN12 DYN5	According to actual condition	N/A
Expiry Days	Originally designed as a way of disabling the module after a certain number of days operation. When days of use expires, the module will automatically jump to the expiration prompt interface, which cannot be used normally. Only be used after entering the registration code (the registration code is provided by Sinexcel R&D) <i>Note: Do not change it without the guidance of Sinexcel engineer.</i>	>0	0	Value
Out Curr. CT Ratio	The specific settings just for other large-capacity models.	>0	300	Value
LVRT	LVRT: Low Voltage Ride Through Enable: If supply voltage drops below 90% of voltage lower limit for more than 2s that module will stop working. Disable: The module only works in its entire voltage tolerance range. Once lower than voltage limit, module will stop working. For example, SVG 400V (It's voltage range is 228~456V) that means when you choose "Enable" to work, when the voltage drops the	Enable Disable	Disable	N/A

	<p>voltage lower voltage(228V) 90%(below 205, 2V), the time lasts 2s or more, the SVG will stop working automatically, but within 205, 2V, the SVG still working.</p> <p>If “Disable” is selected, the SVG will stop working when the voltage reaches the lower limit (228V).</p> <p><u>Note: ① The voltage lower the compensation performance will be worse. ②Please contact engineer of Sinexcel before changing this parameter.</u></p>			
Fan gear	<p>It is for maximum speed adjusted of fan. 1 is 100% speed, 0.9 is 90% speed.</p> <p>Generally, this setting is not changed, but when the customer feels that the machine is noisy, you can contact the engineer of Sinexcel to adjust it.</p>	0.5~1	1.0	Value
L1/L2/L3_grid_THDU_config.	<p>When the Grid THDU of L1/L2/L3 phase shown in the HMI is different with the Grid THDU of L1/L2/L3 phase measured by the power quality detector.</p> <p>Coefficient = Actual Grid THDU of L1/L2/L3 phase value on power quality detector / Grid THDU of L1/L2/L3 phase value on HMI.</p>	>0	1.0	Value
L1/L2/L3_grid_THDI_config.	<p>For factory HMI calibration, customer is forbidden to change it. Only when the customer has to replace a 4.3inch HMI, then the customer may have to re-calibrate these settings by themselves if they do not keep a record of the calibration data before.</p> <p>Eg. If the external power quality analyzer shows the grid THDI is 10%, while Sinexcel HMI shows 12%, you can change the setting of “L1/L2/L3_grid_THDI_config.” to 10/12=0.83 to calibrate Sinexcel HMI.</p>	>0	1.0	Value
L1/L2/L3_load_THDI_config.	<p>When the load THDI of L1/L2/L3 phase shown in the HMI is different with the load THDI of L1/L2/L3 phase measured by the power quality detector.</p> <p>Coefficient = Actual load THDI of L1/L2/L3 phase value on power quality detector / Load THDI of L1/L2/L3 phase value on HMI.</p>	>0	1.0	Value
Product model	Use to choose the correspond product for the screen.	SVG SVG ASVG	According to actual condition	N/A
Clear alarm	Clear all alarm history record	Clear	According to actual condition	N/A
Product model adapt	Automatically choose the correspond product for the screen.	Disable Enable	Disable	N/A

Tools required for upgrade:

Large SD card + card reader or Large SD card + USB Flash disk

Note: The capacity of SD card should be 2G to 16G, otherwise the HMI cannot read the SD card.



Figure A- 10 SD Card

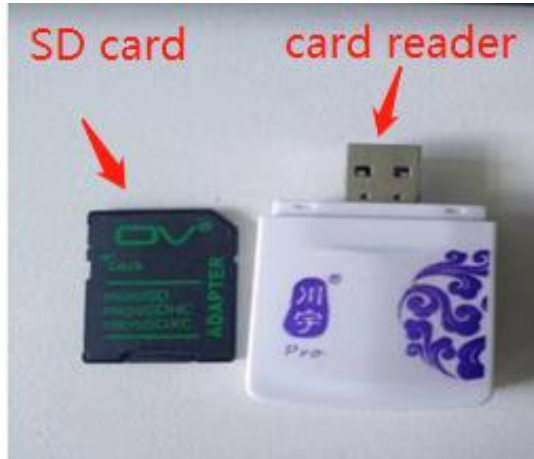

Figure A- 11 SD card + card reader

Step 1: Please format SD card and USB card with computer. When you format the SD card, the File system please select 'FAT32', the Allocation unit size please select '4096 bytes'. Then click start to complete formatting.

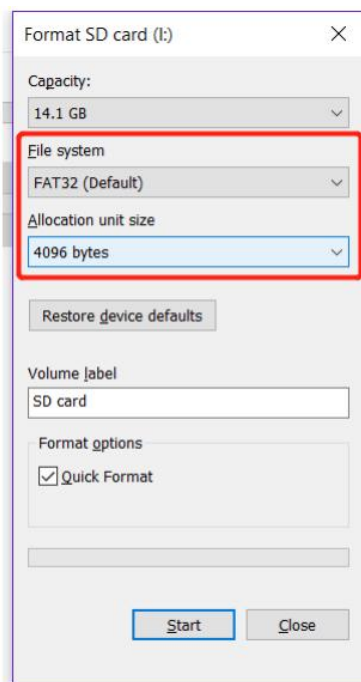

Figure A- 12 Format SD Card Figure



A- 13 Format

Sinexcel

Note: Some PC has no option to format the U disk into 'FAT32', please download the software (for example: DiskGenius) and use the software to format it to 'FAT32'.

Step 2: Find the firmware ZIP file provided by Sinexcel (different HMI has different software version), the firmware folder includes two packages 'DWIN_SET', 'monitor.tar.gz'. ('DWIN_SET' is to upgrade monitor screen interface, 'monitor.tar.gz' is used to upgrade the monitor board, as shown in below Figure).

Note: 'DWIN_SET' is a folder package, please copy the whole folder 'DWIN_SET' to the root menu of SD card, do not change the folder name 'DWIN_SET'.

'monitor.tar.gz' is a zip file, do not unzip it, please copy The 'monitor.tar.gz' to the root menu of USB disk directly.

If using SD card and card reader, please copy both file into the root menu of SD card.



Figure A- 14 Zip

Step 3: Please energize the 7-inch HMI, then insert the SD Card into the interface of 7-inch HMI.



Figure A- 15 Inserting



Figure A- 16 Inserted

Sinexcel

Wait for 10 seconds, HMI will start the upgrade process by itself. The HMI screen will turn into blue and start to flash the picture, wait until the flashing process is finished, then the HMI will reboot.



Figure A- 17 Updating

Step 4: Turn off the power first (or unplug the communication cable of the 7-inch HMI), take out the SD card and insert the USB disk into the monitor USB port.

Turn on the power again (or plug the communication cable of the 7-inch HMI), if the upgrade is completed, the 7-inch HMI will enter the main interface, and the buzzer of the HMI will beep around six times.

Note: If using card reader, insert the SD card to card reader first, then insert the card reader to the USB port.

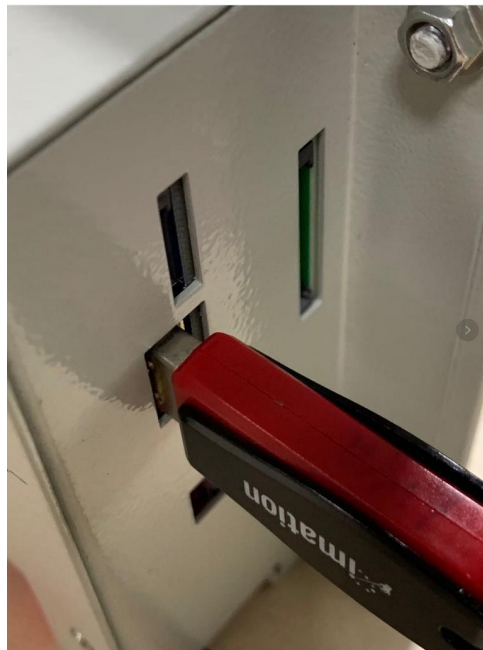

Figure A- 18 Card reader

Step 5: Enter the HMI menu, click about, then check the software version to confirm whether the upgrade is success.

Note: Mxxx is the monitor software version, for example: M311

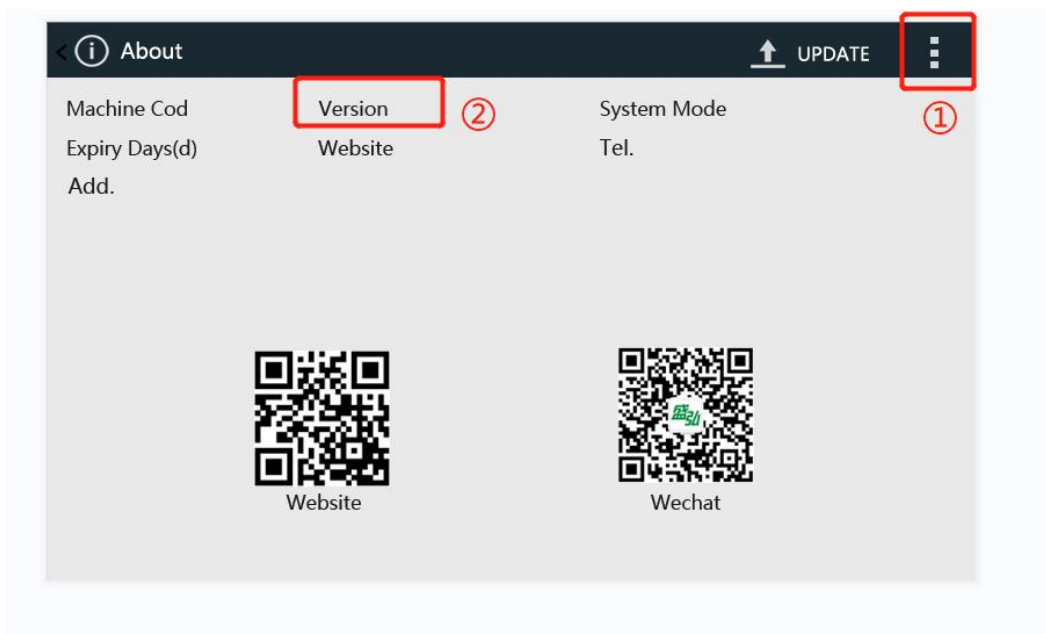

Figure A- 19 HMI Version Check

Step one: Click the menu and choose 'ABOUT';

Step two: Check the version;

SINEXCEL 4.3-INCH HMI SOFTWARE UPGRADE INSTRUCTION

Step 1: Use DuPont Lines to connect the J-link connector to the PCBA board corresponding terminals referring to the figure and table below. The green indicator light stays on when the connection complete.

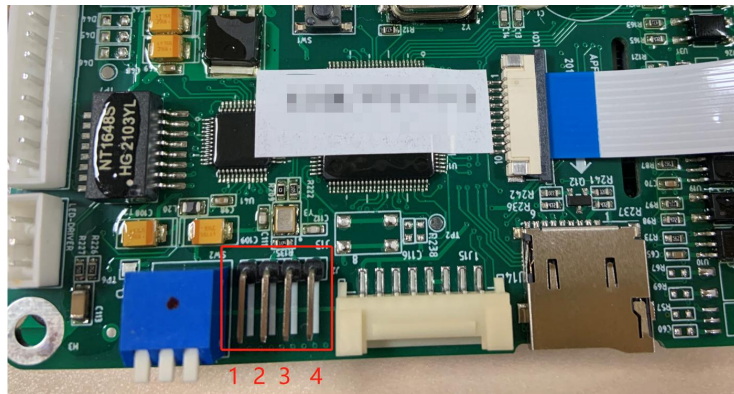
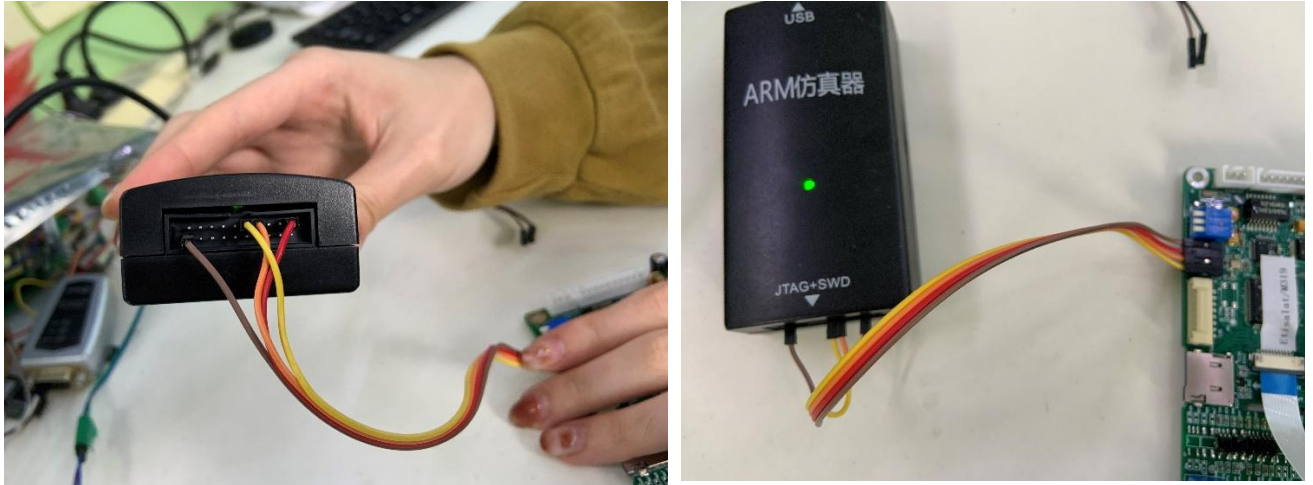

For SWD connector:

Table A- 5 SWD connector

PCBA terminals	SWD terminals	J-Link terminals Num.
1	GND	20
2	VTref/3.3V	1
3	SWDIO	7
4	SWCLK	9

Note: It doesn't need an additional power supply when updating the Control board (PCBA).

Sinexcel

Step 2: Check the Drivers of J-Link in Device Manager. The drivers will be installed automatically when insert the J-Link connector to PC.



Figure A- 20 J-Link connect

Step 3: Install Setup_JLinkARM_V486b.exe JLINK root directory to find J-Flash, run the program.

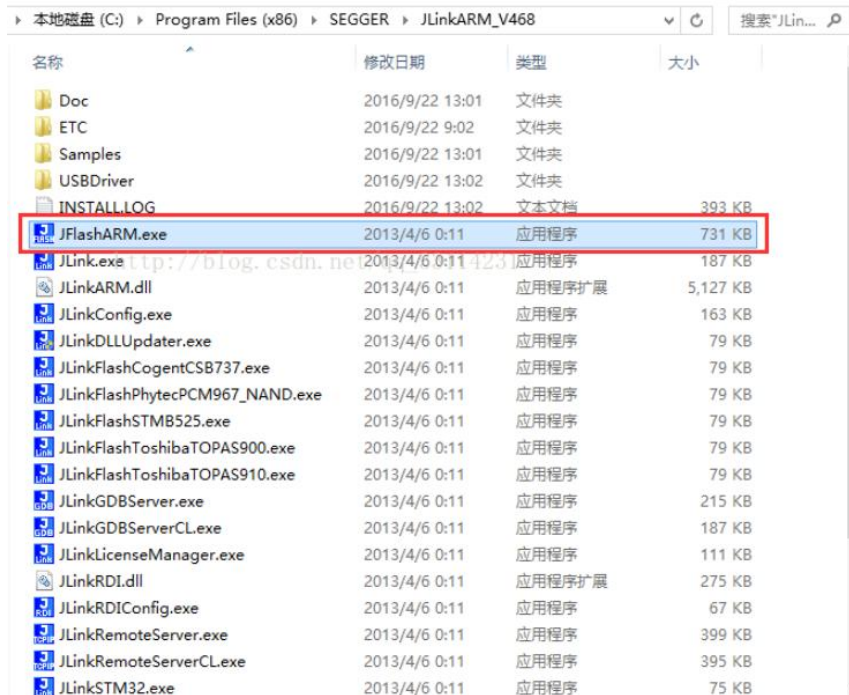

Figure A- 21 Application

Sinexcel

Step 4: Option-->Project Settings-->CPU Device

Options-- choose chip type--STM21F103VET6

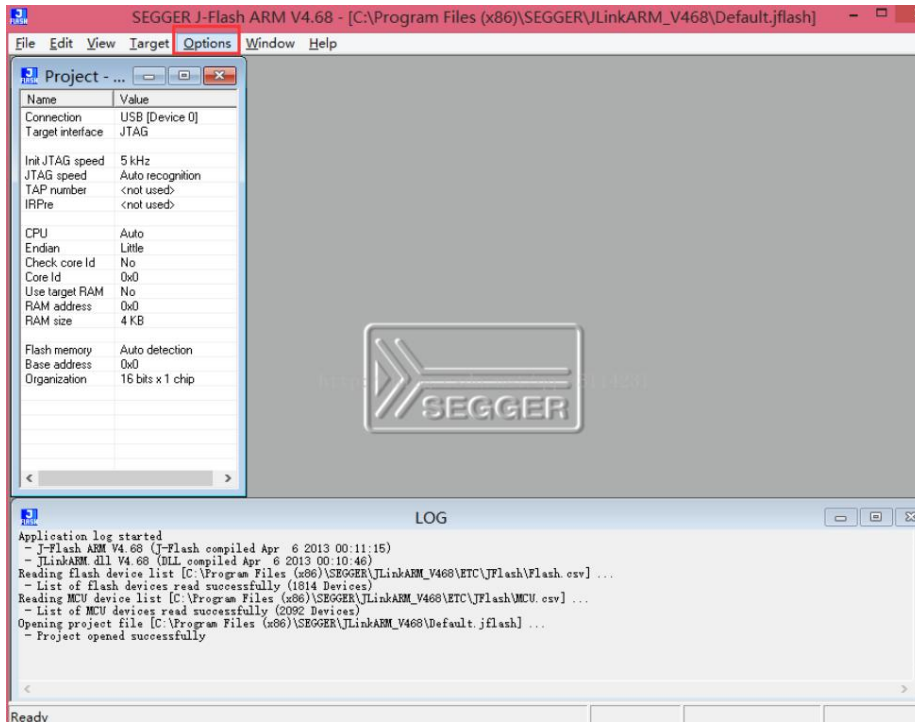

Figure A- 22 Option

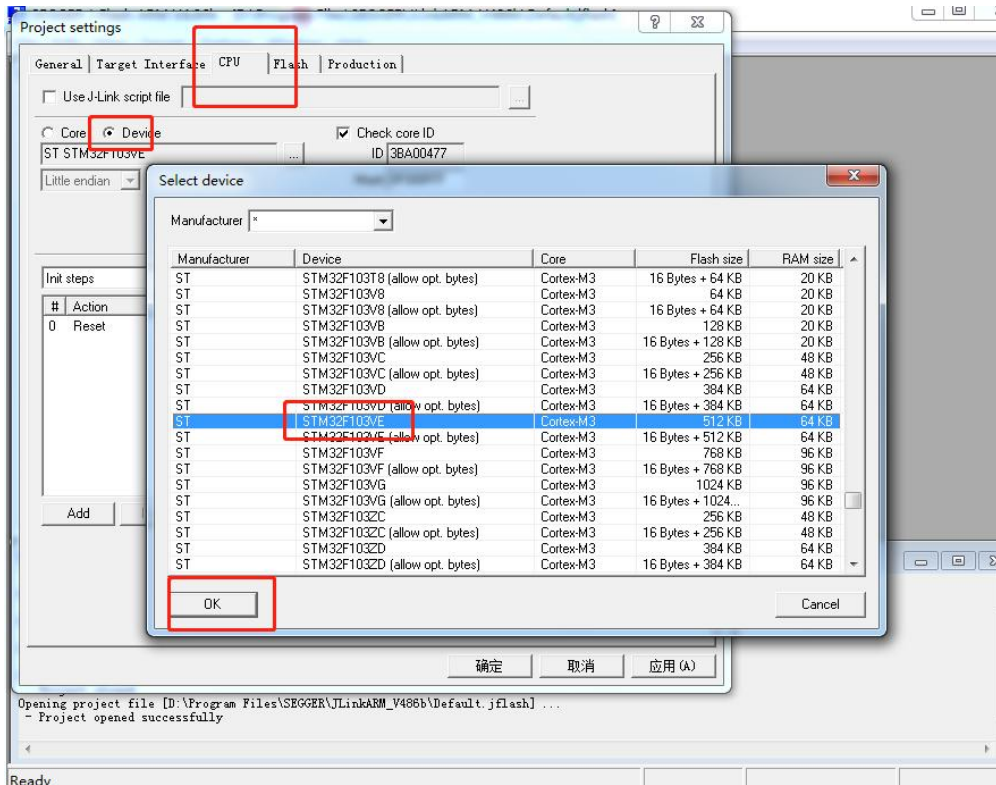

Figure A- 23 STM21F103VET6

Sinexcel

Step 5: Option-->Project Settings-->Target Interface

Choose 'SWD'. And click 'OK'.

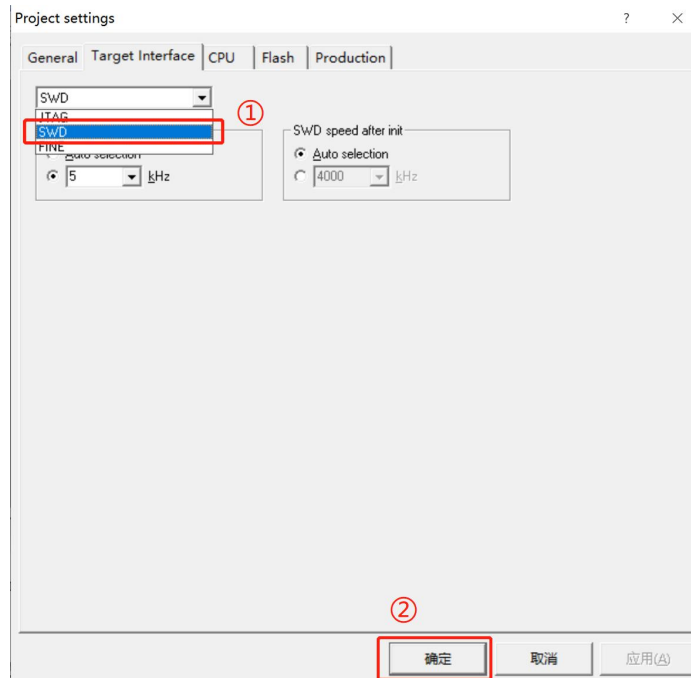

Figure A- 24 SWD

Step 6: Target-->Connect JLINK

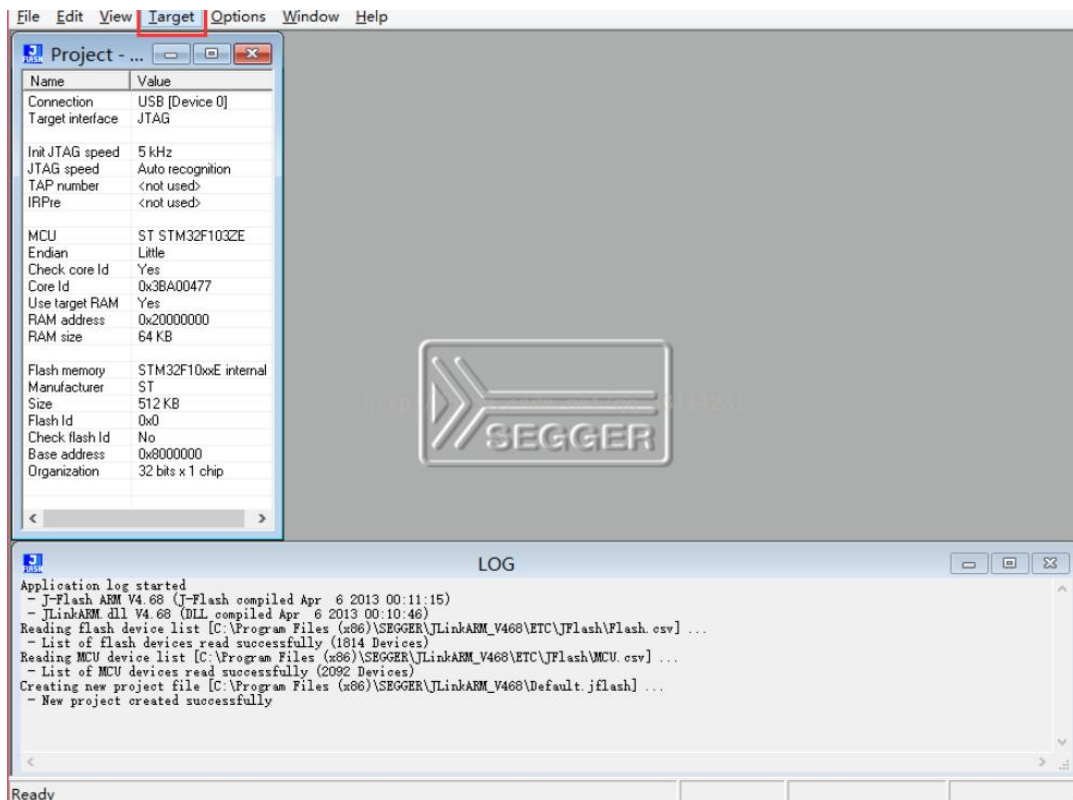

Figure A- 25 Target

Step 7: APF-105.hex put into J-flash (Different hex software according to different units' version)

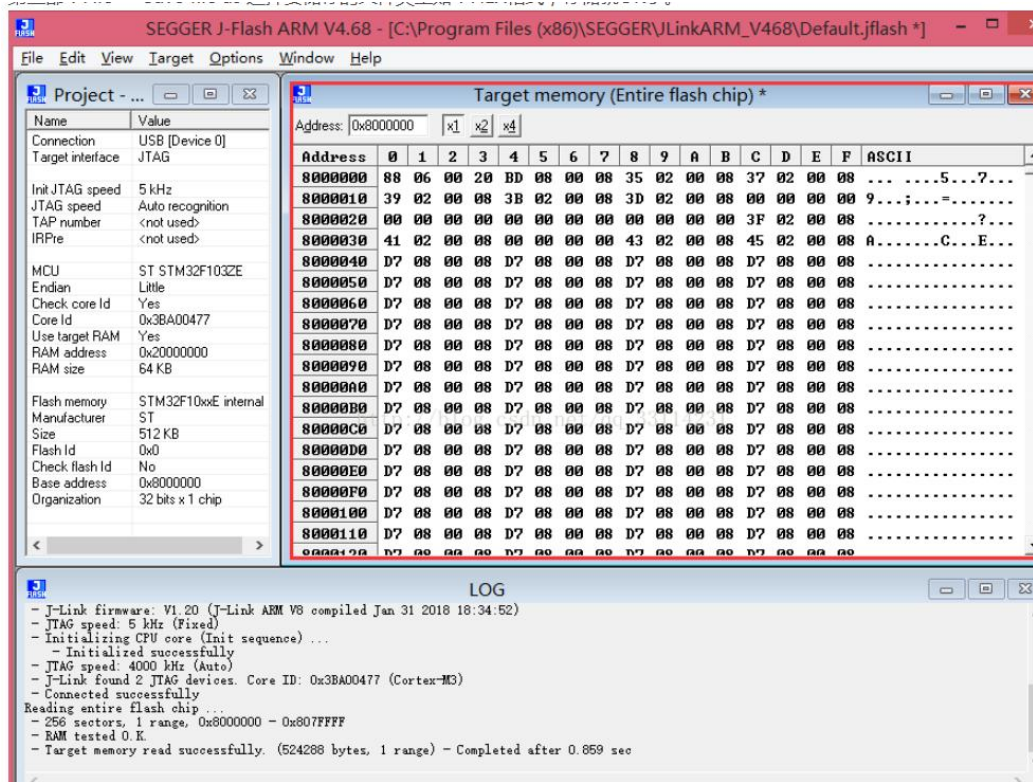

Figure A- 26 Target Memory

Step 8: Target-->Connect JLINK; Target-->Program(F5) Completed

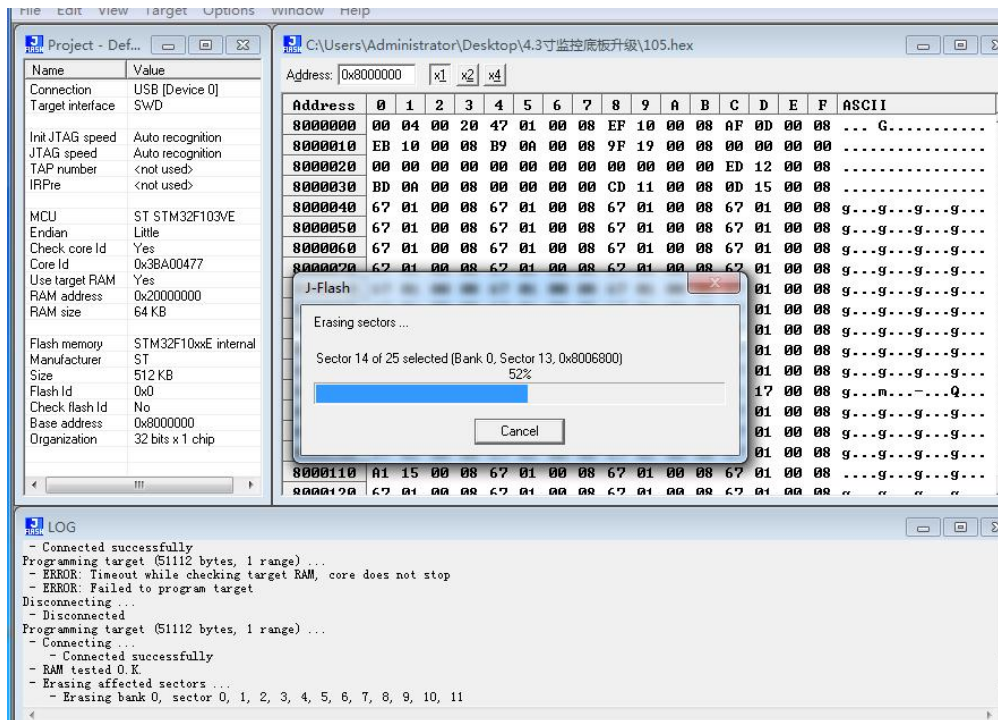

Figure A- 27 Connecting

Sinexcel

Step 9: The user need to prepare a micro SD card first. Samsung or Kinston brand is better.

Please format SD card with computer. When you format the SD card, the File system please select 'FAT32', the Allocation unit size please select '4096 bytes'. Then click start to complete formatting.

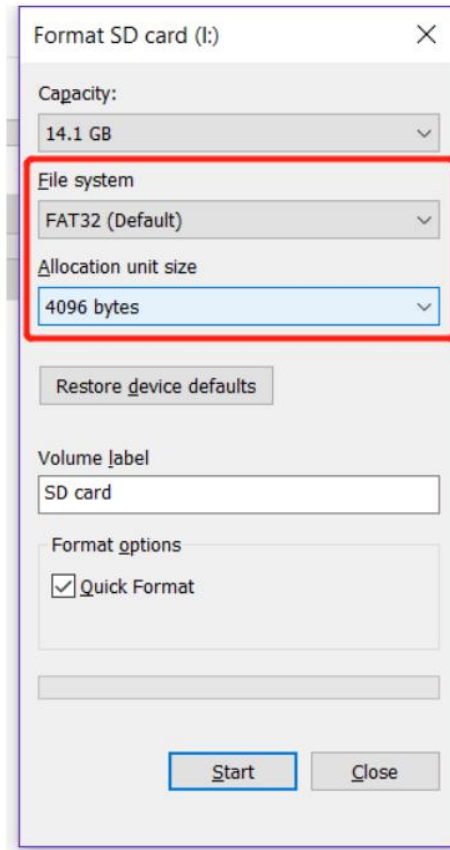

Figure A- 28 Format SD Card

Step 10: There is a file named "DWIN_SET.zip", unzip this package and you can get a folder named "DWIN_SET". Copy this folder to the SD card's root directory. Do not change the filename and make sure this folder is in the SD card's root directory

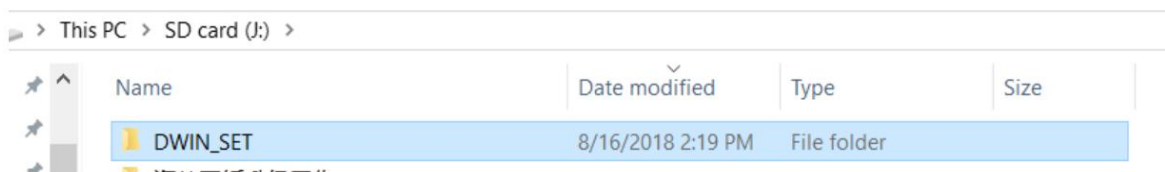

Figure A- 29 This folder should be in the SD card' s root directory

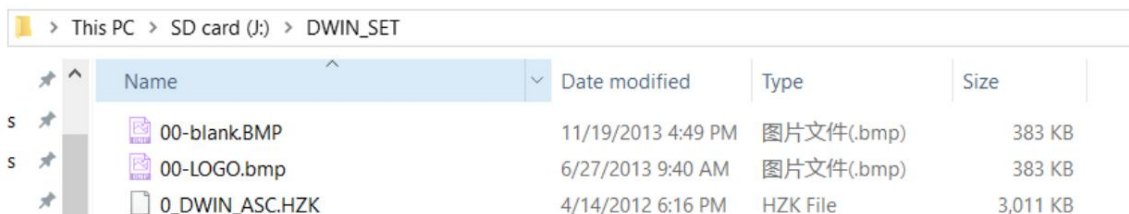

Figure A- 30 Open the folder you can see many '.bmp' files

Sinexcel

Step 11: Turn off the power of module

There is a SD card interface right behind the display screen, put the SD card into the interface. Pay attention that HMI has two circuit boards: monitor board and control board, each circuit board has a SD card interface, do not make it wrong. You should put the SD card into the interface of the monitor board.

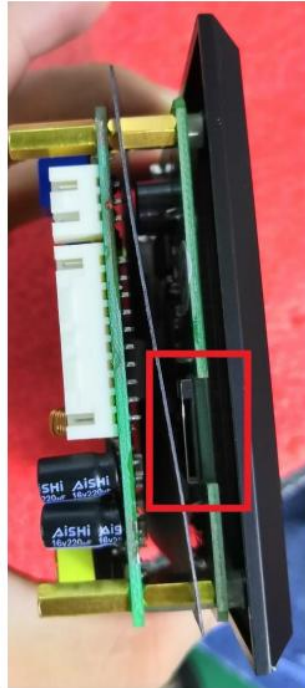

Figure A- 31 The position of SD Card Insert Interface



Figure A- 32 Do not find the wrong position to operate

Sinexcel

Step 12: Turn on the power of module.

The HMI software will update automatically. If you see the screen turn blue, it means the HMI will start the update. During the update, you can see the display screen is changing fast, this is normal. When the display screen stop changing, it means HMI software update is done. You can check if the HMI software has been upgraded successfully. After upgrading the software successfully, please remove the SD card.

Before delivery of the module, Sinexcel will perform a calibration in the following four aspects: the parameter settings of **Inductor current**, **CT Current**, **Inverter Current** and **Input Voltage** in corresponding HMI interfaces. This document is to illustrate the calibrating process.

1. Preparations & Settings

- 1) Unit: SVG with 4.3-inch or 7-inch HMI
- 2) Instruments: Multimeter (600VAC testing range), Current clamp (200A-AC range)
- 3) Check whether the power cables and the CT cables are connected properly.
- 4) Parameter setting before test:

- a) Use password of '654321' to log in the 'Setting' interface.

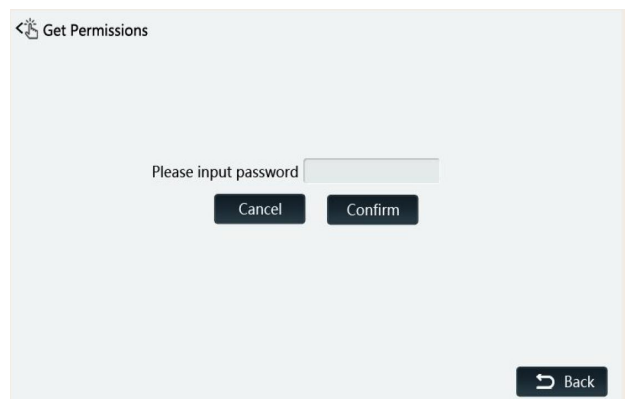

- b) Press the button of 'System Parameter' and find the setting for 'Operation Mode'.

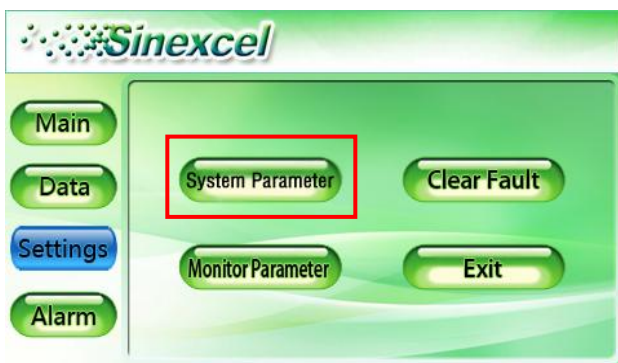

Sinexcel

c) Set the operation mode to 'Auto-ageing'.

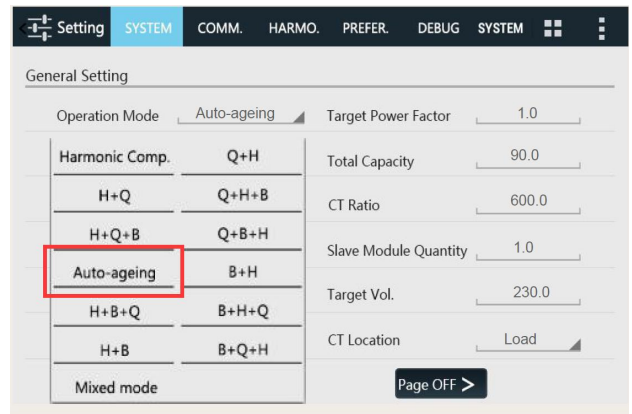

d) Set the 'Inductor Current config.' to 'Capacitive' and set 'Comp. Rate' to 0.8.

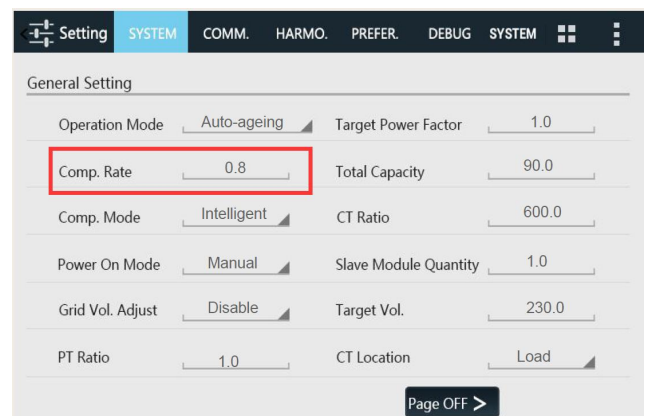
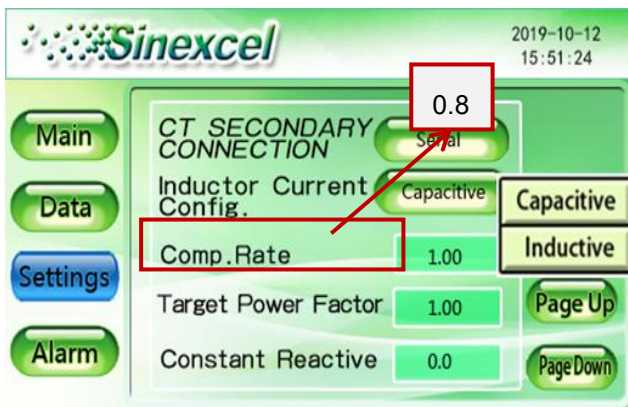
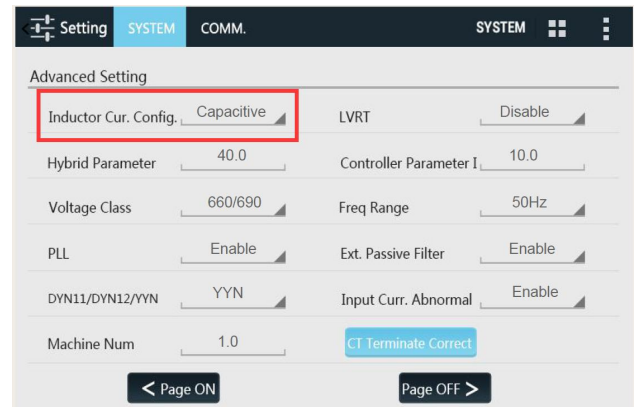
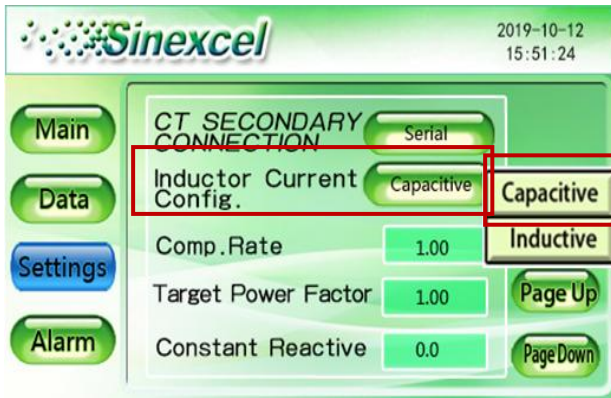

Sinexcel

- e) Set the 'CT location' to 'Load Side' and check the exterior CT is connected properly. And please set the Wire system (Network Config) to '3P4W'.

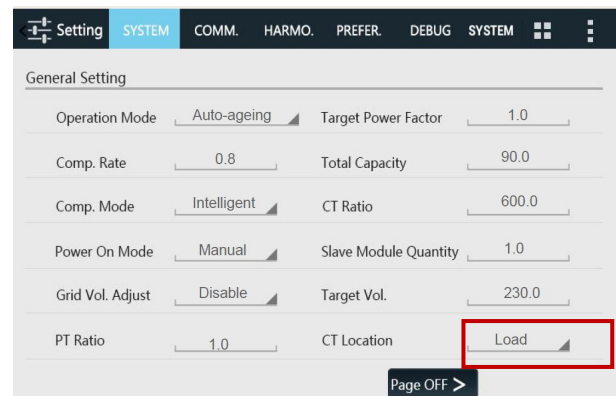
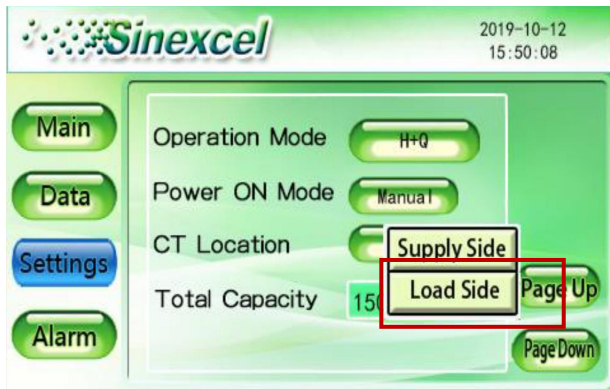

- 5) Before testing, it's essential to examine the data interface of the **Grid Voltage**, the **Waveform** and **Comp. current**. Check if the grid voltage is at normal range, if the Waveform displays normally and is in positive sequence. And the machine will keep outputting a current under 5A when remaining standby. And please do the measurements in accordance with the follow orders and processes.

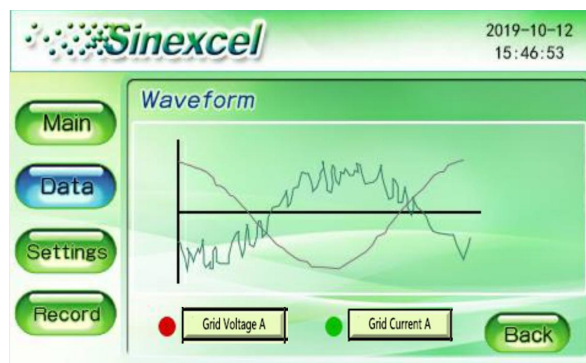
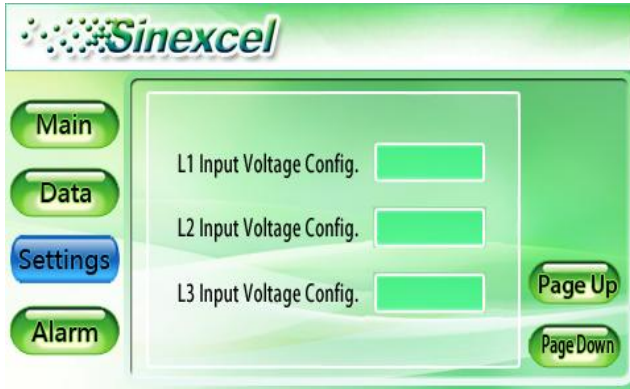

Figure A- 33 Factory Calibration for SVG module

Sinexcel

2. Input Voltage Configuration

- 1) Keep the module in standby.
- 2) Use the Multimeter to measure the Phase Voltage of three-phase and record.
- 3) Fill in the measurement value in the corresponding items shown below.



- 4) Back to the Data interface and check the 'Grid Voltage'. Normally its showing Voltage data should be approximated to the number which you input in procedure 3). For instance, 230.1\230.1\231.5 was input in 3), so the same may be displayed in Grid Voltage interface.



Figure A- 34 Factory Calibration for SVG module

Sinexcel

3. CT Current Configuration (without loads) & Inverter Current Config. interface

- 1) Power-on and wait till the Comp. current is stable.

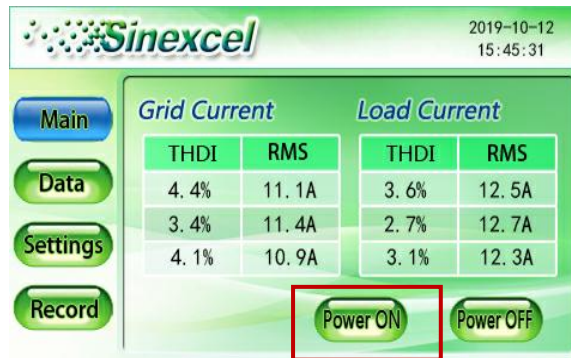
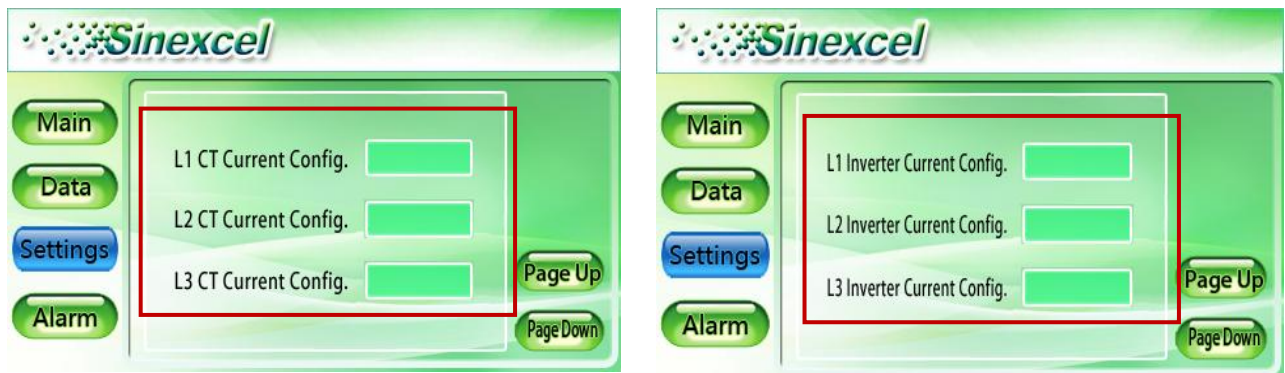

Figure A- 35 Power ON

- 2) Use the Current clamp to measure the Line current of L1/L2/L3 where the CTs placed in.
- 3) Input the same data in Settings-CT current config interface and Inverter Current Config interface. For 7-inch HMI, the setting is in the same interface with Voltage configuration.



- 4) Back to the Data interface and check the 'Comp. Current'.

4. Inductor Current Configuration

- 1) Remain Power-on.
- 2) Set the Inductor current config to 'Capacitive'.

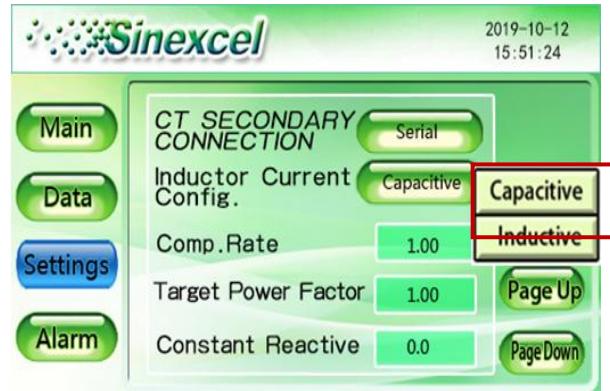

Figure A- 36 Inductor Current Config.

- 3) Back to the comp current interface to check compensating current change. Wait till the current is stable.
- 4) Use the Current clamp to measure the Line current of L1/L2/L3.
- 5) Calculate the average number of 4) and Inverter Current Config for each phase which represented to the Inductive current and the capacitive current. Input the number in the Inductor Current Config interface.



Figure A- 37 L1/L2/L3 Inductor Current Config.

- 6) If input the wrong number, please retake the measurement from 3 the inverter current config.
- 7) Change the Inductor current config to 'Inductive' and back to the data interface to check whether the comp current is normal. For instance, if the total capacity of the unit is 100K, the average Comp. current of the capacitive and inductive mode will be $100K \times 0.8$ (the Comp. rate) = 80K in theory. The capacitive current will be higher than the average while the inductive current will be lower.

INTERFACE & DIMENSIONS

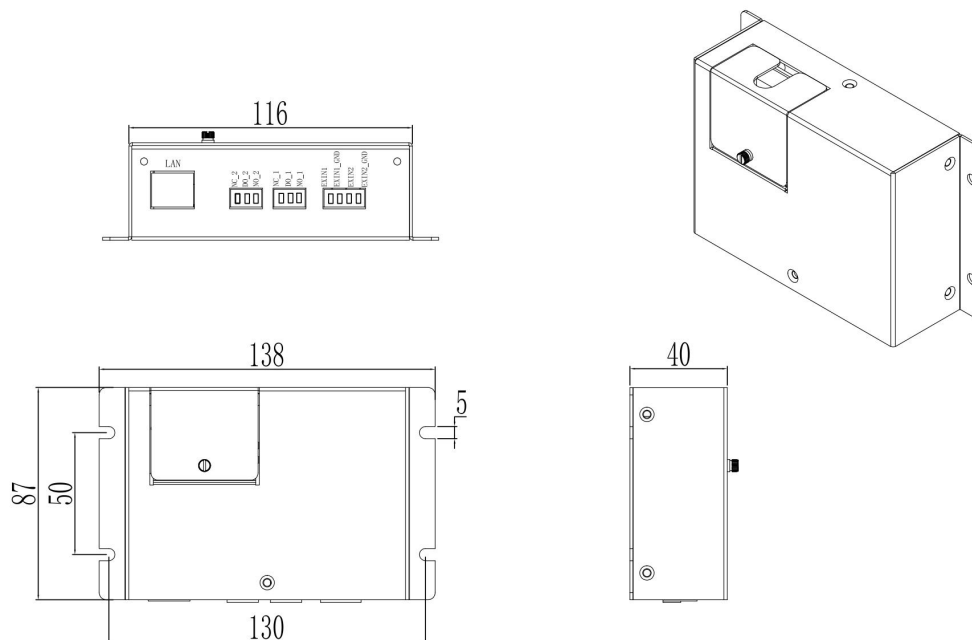

Figure A- 38 Dimensions of Dry Contact Board

Sinexcel dry contact board, which the size is W130*D40*H87mm.

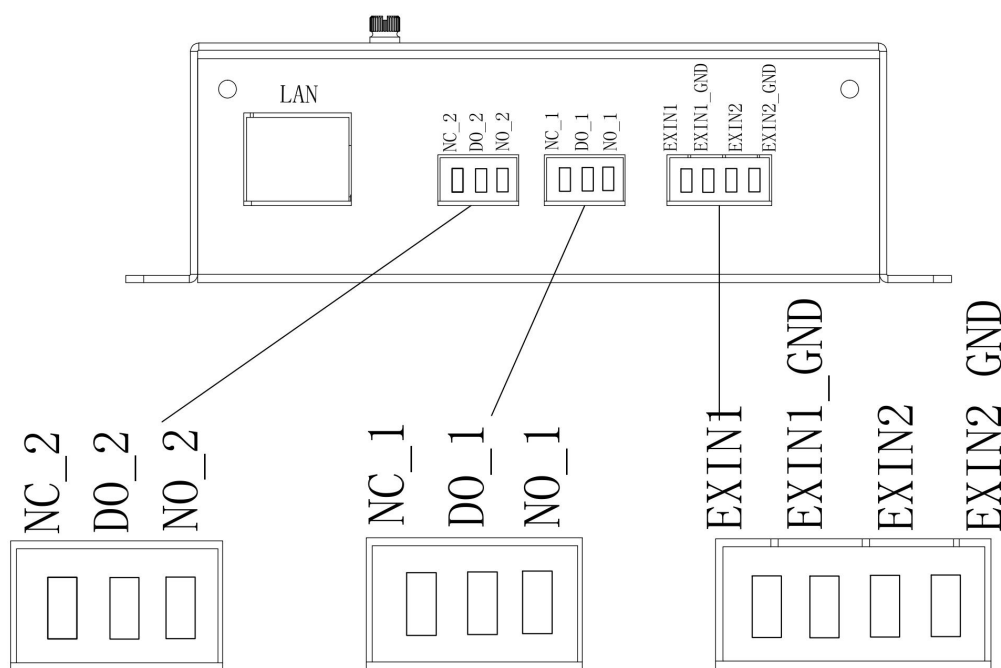

Figure A- 39 Structure of Dry Contact Board

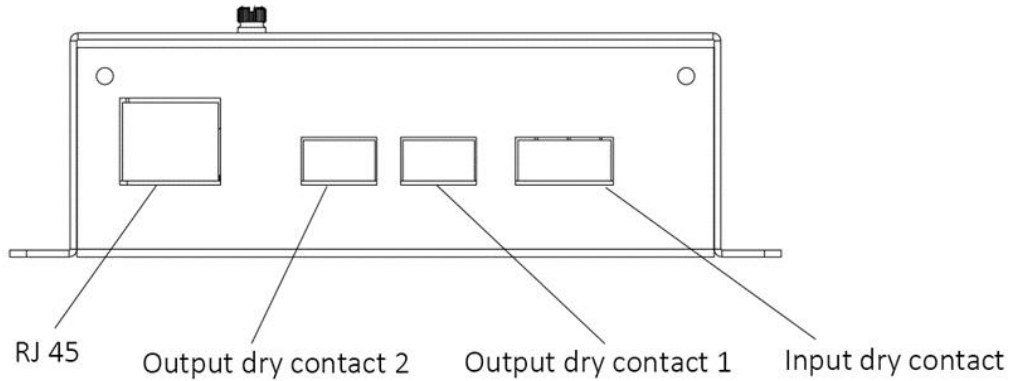

Figure A- 40 Structure of Dry Contact Board_Simplified

Sinexcel dry contact board is a optional accessory which offers 2 additional functions:

- Providing Ethernet port, enables user to build MODBUS TCP communication between the module and external system.
- Providing 2 input dry contacts and 2 output dry contacts. User could use the dry contact to monitor the working status and alarm status through output dry contact, and use input dry contact to control the module to power on or power off.

RJ45 ETHERNET PORT

Sinexcel offers Modbus protocol and RJ45 Ethernet port. The user can access the module to the user LAN through the network cable, then establish communication between the user Ethernet monitoring system and the module based on Modbus.

OUTPUT DRY CONTACT 2

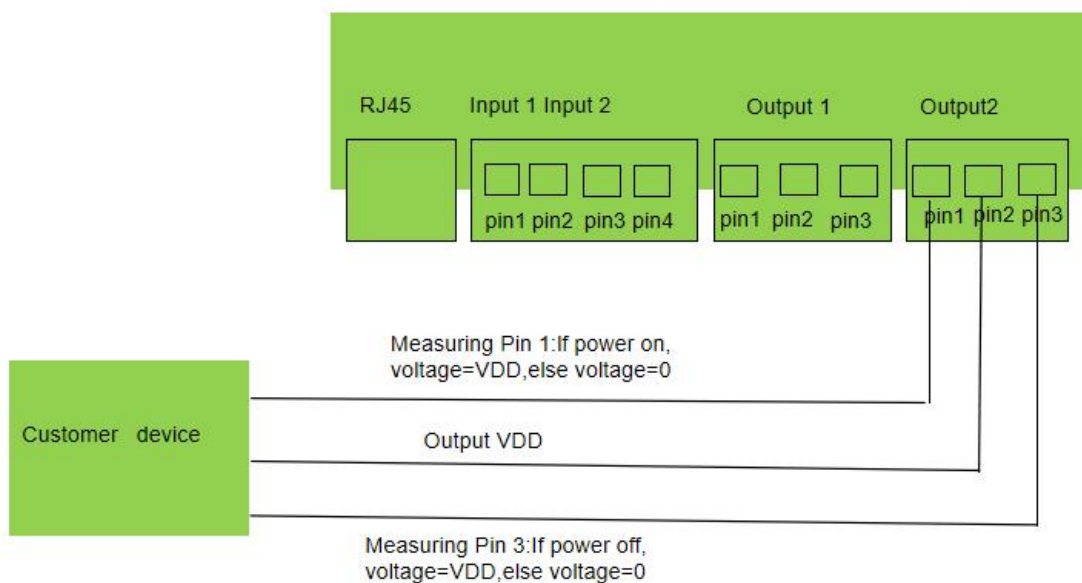

Figure A- 41 Dry contact output 2

This dry contact is used to monitor the on/off status of the module.

As shown in the figure 3, Pin 2 always output high level: VDD. Pin 1 and Pin 3 have two level: high level “VDD” and low level “0” .

In order to monitor the module power status, there is need to measure the output level of Pin 1 and Pin 3.

- If module power is on, Pin 1 output high level: VDD, else output low level: 0.
- If module power is off, Pin 3 output high level: VDD, else output low level: 0.

The user can use the voltage level change of the Pin1 and Pin 3 to design peripheral circuit to monitor the on/off status of the module.

OUTPUT DRY CONTACT 1

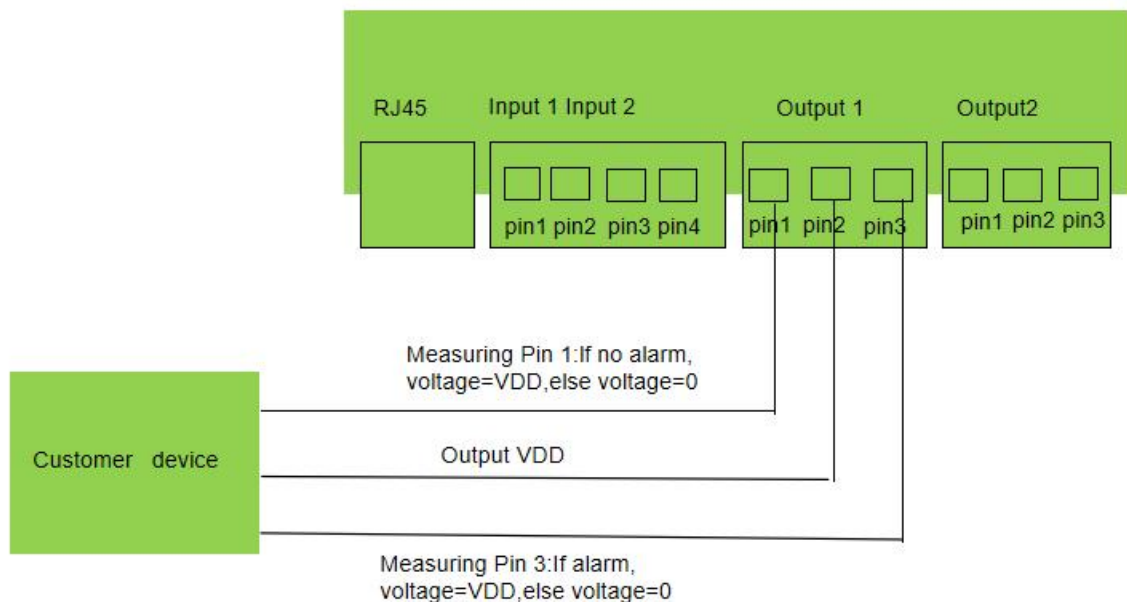

Figure A- 42 Dry contact output 1

This dry contact is used to monitor whether the module have alarm or not.

As shown in the figure 4, Pin 2 always output high level: VDD. Pin 1 and Pin 3 have two level: high level “VDD” and low level “0”.

- If module has no alarm, Pin 1 output high level: VDD, else output low level: 0.
- If module has an alarm, Pin 3 output high level: VDD, else output low level: 0.

The user can use the level change of the Pin1 and Pin 3 to design peripheral circuit to monitor whether the module have alarm or not.

The maximal allowable DC current in the output end is 8A, the maximum DC voltage is 28V and the maximum AC voltage is 277V.

INPUT DRY CONTACT

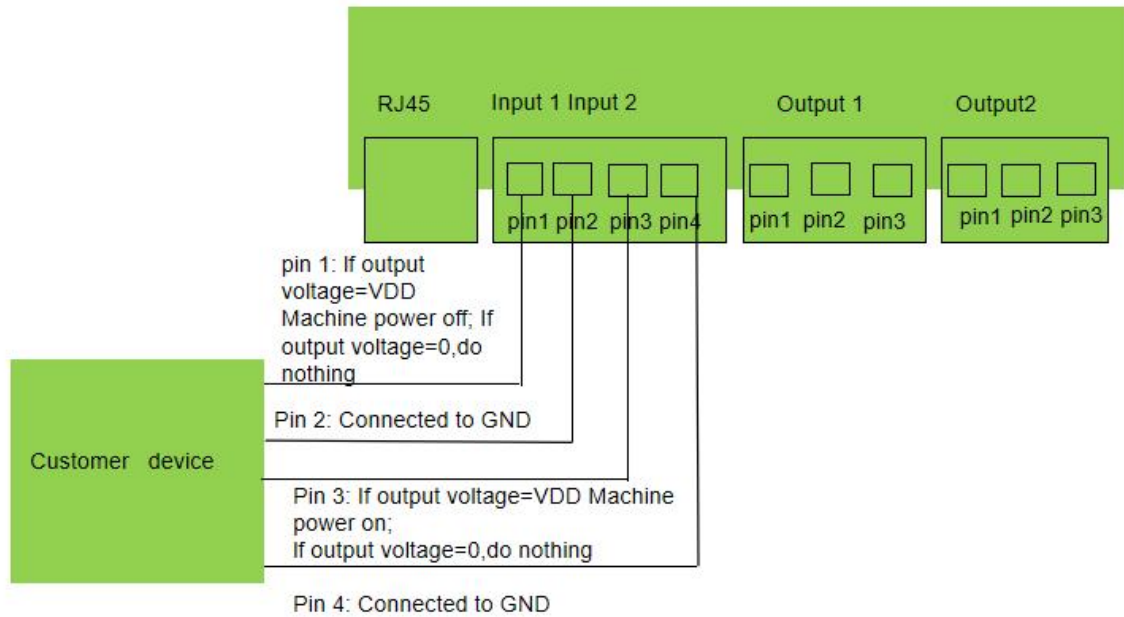

Figure A- 43 Dry contact input

As shown in figure 5, there are four input ports. Pin 2 and Pin 4 are connected to GND.

- If input high level “VDD” to Pin 1, the module will turn off. If input low level “0” to Pin 1, the module will do nothing.
- If input high level “VDD” to Pin 3, the module will turn on. If input low level “0” to Pin 3, the module will do nothing.

The high level range: DC 7V~36V, ideal range is: DC 10V~20V.

DRY CONTACT BOARD INSTALL POSITION

For SVG Ultra series module, the dry contact board space is reserved at the rear side of the module.

The red circle below is the position of dry contact board installed in Sinexcel Ultra SVG

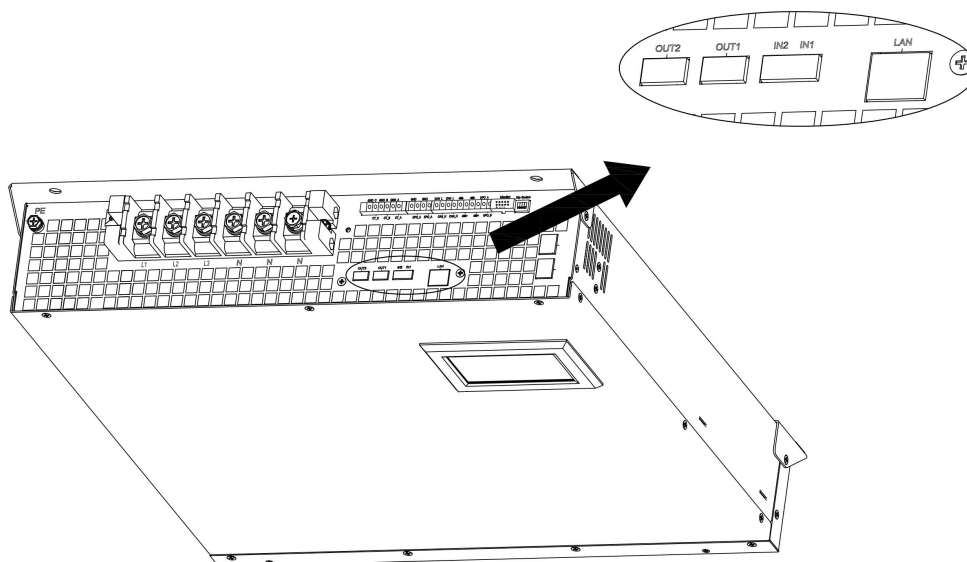

Figure A- 44 SVG wall-mounted Ultra dry contact board position

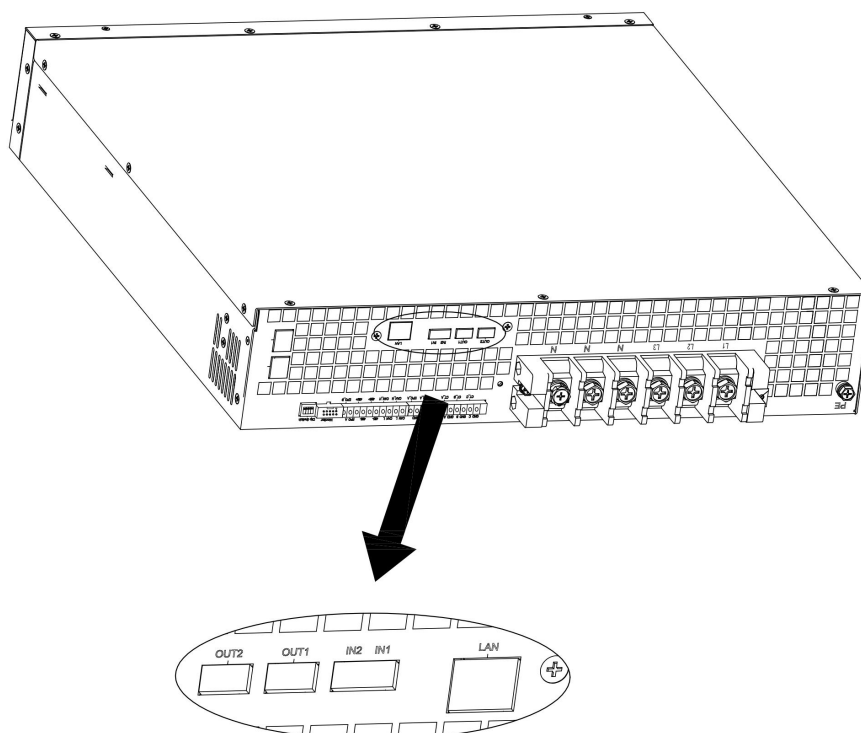

Figure A- 45 SVG rack-mounted Ultra dry contact board position

DRY CONTACT BOARD CONNECTION GUIDANCE

CONNECT TO SINGLE LCD MODULE

Dry contact board and LCD control board both have a black 14-pin port and a white 10-pin port.

The black 14-pin port is used to connect the dry contact signal between two boards. If customers need the dry contact function, they must connect two ports through one 14-pin cable.

The white 10-pin port is used to connect the RJ45 Ethernet port between two boards. If customers need to use the RJ45 Ethernet port on the dry contact board, they must connect two ports through one 10-pin cable. Sinexcel will send customers the 14-pin cable and the 10-pin cable if required.

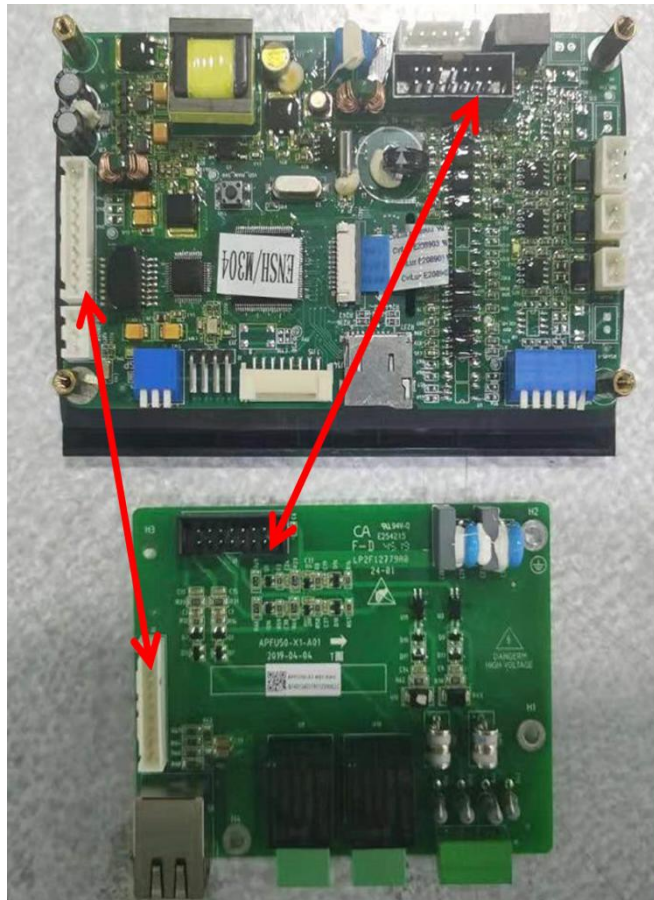

Figure A- 46 Connection to 4.3-inch LCD panel

CONNECT TO 7-INCH HMI

The 7-inch HMI has the Ethernet port itself, it is no need to use the RJ45 Ethernet port of the dry connect board. When connecting dry contact board to 7-inch HMI, just connect the black 14-pin terminal of the dry connect board to the J24 port on the 7-inch HMI.

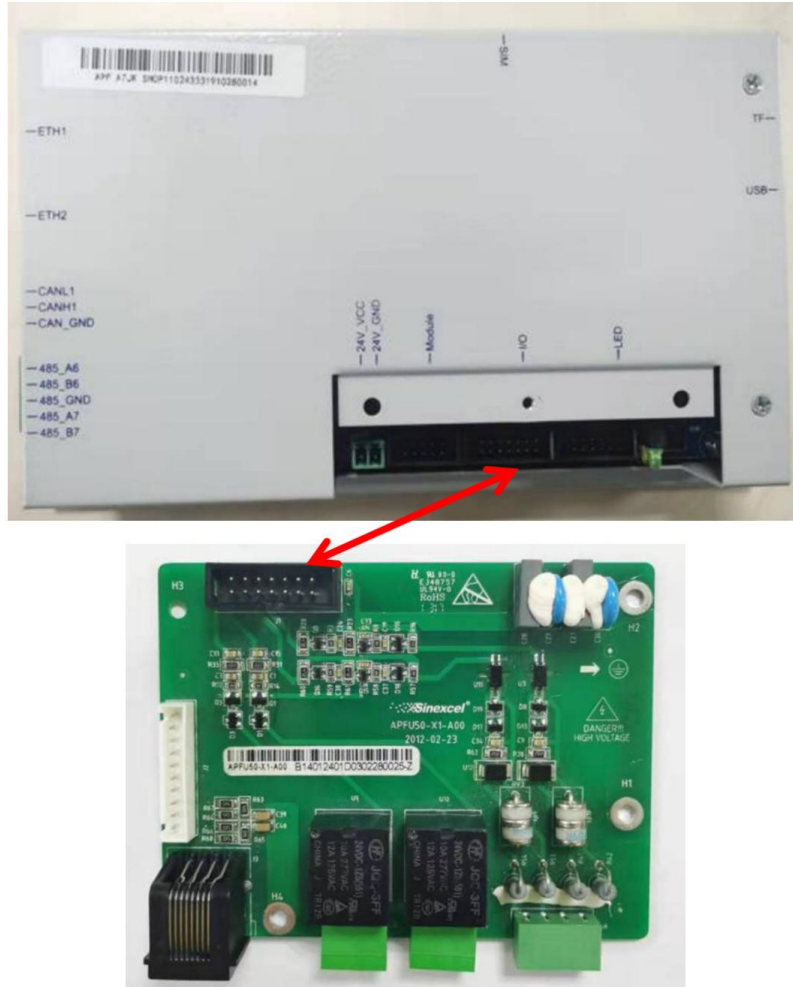

Figure A- 47 Connection to 7-inch HMI

When the dry contact board working with 7-inch HMI, usually the dry contact board is installed outside the module. Sinexcel offers 2 kinds of boxes for customer to protect the board, one is in black and one is in grey (RAL 7035), another one is black color box. Sinexcel is suggests to use black one with SVG module.



Figure A- 48 Dry Contact Board Optional

MODBUS PROTOCOL OUTLINE

Protocol Overview

MODBUS is an application layer protocol and widely used in industrial control. It is the de facto industry standard. This protocol describes the MODBUS communication protocol implemented in Sinexcel product family. Communication uses response mode, the host sends request, then the slave to execute request and response.

Application Scope

This protocol applies to SVG series product, for DSP module data exchange with monitor and for monitor data exchange with background software.

Reference Standard

MODBUS RTU communication protocol standards

Based level communication protocol

Asynchronous serial protocol UART

Physical interface

Two-wire RS485 interface

Data transfer rate

Optional between 9600/19200/38400bps, default is 19200bps.

Character format

The transfer mode is asynchronous mode; half duplex mode; start bit contains 1 bit; data bit contains 8 bits; stop bit contains 1 bit; no check.

DATA TYPE

Integer

Integer storage format is 2 bytes. When transmitting, high bytes D15~D8 go first, and then low bytes D7~D0.

Float



Floating-point storage format is four bytes, using IEEE32 bit standard Floating-point format (Standard C language format). First transmit high bytes D31~D24, second D23~D16, third D15~D8, last transmit low bytes D7~D0.

COMMUNICATION

Communication applies Master-Slave mode, monitor as the host and DSP module as the slave; or backstage software as the host, monitor as the slave.

After the host sends the request, it will wait for the slave to reply within 100ms. If there is no reply after the timeout or an error response is received, the communication process will be considered as failure.

APPLICATION LAYER PACKET/FRAME FORMAT DEFINITION

Data Verification

Data verification uses 16 bits (2byte) cyclic redundancy check (CRC). All information will be involved in verification. The contents of CRC are obtained by the lengthy detection method of loop on the message contents. The CRC content is appended to the end of the message, first in low bytes and then in high bytes. For the specific CRC check, please refer to the Appendix II.

Function Code Supported by device

Function Code	Function Description
02	Read status information and alarming information of the device
03, 04	Read analog data, waveform, histogram, and information of manufacturer
16	Set parameter into device

Function Code 02

Request Frame:

Format	Address	Function Code	Status Bit Start Address		Status Quantity		Check
			High	Low	High	Low	
Byte	1	1	1	1	1	1	2

The address range of the device is 0 ~ 247, and the default address is 1. 0xFF is the broadcast address.

Response Frame:

Format	Address	Function Code	Byte Quantity	Data	Check
Byte	1	1	1	2

Byte Quantity = Status Quantity / 8 + (State Quantity % 8 == 0 ? 0 : 1)

For example, to get all 61 status and alarm analog data:

- TX: 01 02 00 00 00 3D B9 DB
- RX: 01 02 08 00 00 00 00 00 00 00 00 C4 12

Function Code 03, 04



Request Frame:

Format	Address	Function Code	Register Start Address		Register Quantity		Check
			High	Low	High	Low	
Byte	1	1	1	1	1	1	2

Response Frame:

Format	Address	Function Code	Byte Quantity	Data	Check
Byte	1	1	1	2

Byte Quantity = Register Quantity * 2

For example, to get the first frame data (50 analog data):

● Tx: 01 04 00 00 00 64 F1 E1

● Rx: 01 04 C8 xx xxxx... CRCL CRCH

xx means the feedback data. CRCL: check code (low bytes). CRCH: check code (high bytes)

Function Code 16

Request Frame:

Format	Address	Function Code	Register Start Address		Register Quantity		Data Bytes	Data	Check
			High	Low	High	Low			
Byte	1	1	1	1	1	1	2	

Response Frame:

Format	Address	Function Code	Register Start Address		Register Quantity		Check
			High	Low	High	Low	
Byte	1	1	1	1	1	1	2

For example:

To set the operation mode as "Constant Q"

Tx:01 10 20 1c00 02 04 41 40 00 00 7E DF

Rx:01 10 20 1c 00 02 8B CE

Set the Constant reactive as 300 (300kvar inductive power output)

Tx:01 10 20 54 00 02 04 43 96 00 00 9B 09

Rx:01 10 20 54 00 02 0B D8

Error Code

Request Frame:

Format	Address	Function Code	Fault Code	Check
Byte	1	1	1	2

Error Code= Function Code + 0x80

Fault Code

- 01 Function Code Error
- 02 Address Error
- 03 Data Error
- 04 Device Failure
- 05 Confirm
- 06 Busy

REQUEST/RESPONSE INFORMATION DETAILS

ACQUIRE STATUS INFORMATION AND ALARMING INFORMATION OF THE DEVICE

Function Code = 02

Status Start Address = 0x0000

Table A- 6Acquire status information and alarming information of the device

Status Address	Byte	Description	Remark	Data Attribute
0x0000	1	Initialize flag	0: No Initialization, 1: Initialization	
0x0001	1	Running status	0: Standby 1: Run	
0x0002	1	Reserved		
0x0003	1	Reserved		
0x0004	1	Reserved		
0x0005	1	Reserved		
0x0006	1	Reserved		
0x0007	1	Reserved		
0x0008	1	Reserved		
0x0009	1	Reserved		
0x000A	1	Reserved		
0x000B	1	Reserved		
0x000C	1	Reserved		
0x000D	1	Reserved		
0x000E	1	Reserved		
0x000F	1	Reserved		
0x0010	1	Dry contact output 1	0: Low level 1: High level	
0x0011	1	Dry contact output 2	0: Low level 1: High level	
0x0012	1	Dry contact output 3	0: Low level 1: High level	
0x0013	1	Dry contact output 4	0: Low level 1: High level	
0x0014	1	Dry contact output 5	0: Low level 1: High level	
0x0015	1	Dry contact output 6	0: Low level 1: High level	
0x0016	1	Dry contact output 7	0: Low level 1: High level	
0x0017	1	Dry contact output 8	0: Low level 1: High level	
0x0018	1	Lightning arrester failure	0: Normal 1: Abnormal	
0x0019	1	Reserved		
0x001A	1	Reserved		
0x001B	1	Reserved		
0x001C	1	Reserved		
0x001D	1	Reserved		
0x001E	1	Reserved		
0x001F	1	Reserved		
0x0020	1	Reserved		
0x0021	1	Reserved		
0x0022	1	Reserved		
0x0023	1	Reserved		
0x0024	1	Reserved		

0x0025	1	Reserved	
0x0026	1	Reserved	
0x0027	1	Reserved	
0x0028	1	Inverter short-circuit failure	0: Normal 1: Abnormal
0x0029	1	Output current abnormal	0: Normal 1: Abnormal
0x002A	1	Auxiliary power failure	0: Normal 1: Abnormal
0x002B	1	Fuse failure	0: Normal 1: Abnormal
0x002C	1	Fan failure	0: Normal 1: Abnormal
0x002D	1	Inverter over-temperature	0: Normal 1: Abnormal
0x002E	1	CT ratio setting failure	0: Normal 1: Abnormal
0x002F	1	Inverter overload failure	0: Normal 1: Abnormal
0x0030	1	System failure	0: Normal 1: Abnormal
0x0031	1	Input frequency abnormal	0: Normal 1: Abnormal
0x0032	1	Input voltage abnormal	0: Normal 1: Abnormal
0x0033	1	Input phase reverse	0: Normal 1: Abnormal
0x0034	1	Control software compatibility failure	0: Normal 1: Abnormal
0x0035	1	Controller parameter setting failure	0: Normal 1: Abnormal
0x0036	1	Monitoring parameter setting failure	0: Normal 1: Abnormal
0x0037	1	Capacity reading failure	0: Normal 1: Abnormal
0x0038	1	Emergency stop	0: Normal 1: Abnormal
0x0039	1	Busbar differential abnormal	0: Normal 1: Abnormal
0x003A	1	CT current zero point calibration failure	0: Normal 1: Abnormal
0x003B	1	Module communication failure	0: Normal 1: Abnormal
0x003C	1	Module software compatibility failure	0: Normal 1: Abnormal
0x003D	1	Capacitor over-current	0: Normal 1: Abnormal
0x003E	1	Soft-starter failure	0: Normal 1: Abnormal
0x003F	1	Sync signal failure	0: Normal 1: Abnormal
0x0040	1	Grid voltage sampling failure	0: Normal 1: Abnormal
0x0041	1	Hall censor failure	0: Normal 1: Abnormal
0x0042	1	Busbar sampling failure	0: Normal 1: Abnormal
0x0043	1	Air switch abnormal disconnect	0: Normal 1: Abnormal
0x0044	1	Electric operating mechanism failed to connect	0: Normal 1: Abnormal
0x0045	1	Electric operating mechanism failed to disconnect	0: Normal 1: Abnormal

0x0046	1	Output current unbalance!!!	0: Normal 1: Abnormal	
0x0047	1	Harmonics exceed limits	0: Normal 1: Abnormal	
0x0048	1	Cooling system failure	0: Normal 1: Abnormal	
0x0049	1	422 Communication failure	0: Normal 1: Abnormal	
0x004A	1	CAN communication failure	0: Normal 1: Abnormal	

ACQUIRE ANALOG DATA

Function Code = 03, 04

Register Start Address= 0x0000

Table A- 7 Acquire analog data

Register Address	Byte	Description	Unit	Data Attribute
0x0000	4	L1 Load Current	A	
0x0002	4	L2 Load Current	A	
0x0004	4	L3 Load Current	A	
0x0006	4	L1 Load THDI	%	
0x0008	4	L2 Load THDI	%	
0x000A	4	L3 Load THDI	%	
0x000C	4	L1 Load Power Factor		
0x000E	4	L2 Load Power Factor		
0x0010	4	L3 Load Power Factor		
0x0012	4	L1 Inductor Current	A	
0x0014	4	L2 Inductor Current	A	
0x0016	4	L3 Inductor Current	A	
0x0018	4	L1 Grid Apparent Power	kVA	
0x001A	4	L2 Grid Apparent Power	kVA	
0x001C	4	L3 Grid Apparent Power	kVA	
0x001E	4	L1 Active Power	kW	
0x0020	4	L2 Active Power	kW	
0x0022	4	L3 Active Power	kW	
0x0024	4	N Line Grid Current	A	
0x0026	4	N Line Load Current	A	
0x0028	4	L1 Grid Current	A	
0x002A	4	L2 Grid Current	A	
0x002C	4	L3 Grid Current	A	
0x002E	4	L1 Grid THDI	%	
0x0030	4	L2 Grid THDI	%	
0x0032	4	L3 Grid THDI	%	
0x0034	4	L1 Grid Power Factor		
0x0036	4	L2 Grid Power Factor		
0x0038	4	L3 Grid Power Factor		
0x003A	4	Temperature1	°C	
0x003C	4	Temperature2	°C	
0x003E	4	Temperature3	°C	
0x0040	4	L1 Grid Reactive Power	kVar	
0x0042	4	L2 Grid Reactive Power	kVar	
0x0044	4	L3 Grid Reactive Power	kVar	
0x0046	4	L1 Grid COSPHI		
0x0048	4	L2 Grid COSPHI		
0x004A	4	L3 Grid COSPHI		
0x004C	4	L1 Load Reactive Power	kVar	
0x004E	4	L2 Load Reactive Power	kVar	

Sinexcel

0x0050	4	L3 Load Reactive Power	kVar	
0x0052	4	L1 Comp Current	A	
0x0054	4	L2 Comp Current	A	
0x0056	4	L3 Comp Current	A	
0x0058	4	L1 Comp Current Load Rate	%	
0x005A	4	L2 Comp Current Load Rate	%	
0x005C	4	L3 Comp Current Load Rate	%	
0x005E	4	Temperature 4	°C	
0x0060	4	Temperature5	°C	
0x0062	4	Temperature6	°C	
0x0064	4	L1 Load Apparent Power	kVA	
0x0066	4	L2 Load Apparent Power	kVA	
0x0068	4	L3 Load Apparent Power	kVA	
0x006A	4	L1 Load Active Power	kW	
0x006C	4	L2 Load Active Power	kW	
0x006E	4	L3 Load Active Power	kW	
0x0070	4	L1 Load COSPHI		
0x0072	4	L2 Load COSPHI		
0x0074	4	L3 Load COSPHI		
0x0076	4	L1 Grid Voltage	V	
0x0078	4	L2 Grid Voltage	V	
0x007A	4	L3 Grid Voltage	V	
0x007C	4	L1 Grid Frequency	Hz	
0x007E	4	L2 Grid Frequency	Hz	
0x0080	4	L3 Grid Frequency	Hz	
0x0082	4	L1 Grid THDU	%	
0x0084	4	L2 Grid THDU	%	
0x0086	4	L3 Grid THDU	%	
0x0088	4	Config Variable 1		
0x008A	4	Config Variable2		
0x008C	4	Config Variable3		
0x008E	4	Config Variable4		
0x0090	4	Config Variable5		
0x0092	4	Config Variable6		
0x0094	4	Operation Time	Sec	
0x0096	4	Over 50% Load Operation Time	Sec	
0x0098	4	Below 50%Load Operation Time	Sec	
0x009A	4	Positive DC Bus Voltage	V	
0x009C	4	Negative DC Bus Voltage	V	
0x009E	4	Inductor Temperature	°C	
0x00A0	4	Capacitance Current	0.01A	

READ THE WAVEFORM DATA OF THE DEVICE(WAVEFORM)

Function Code = 03, 04
 Register Start Address = 0x0500

A complete waveform consists of 128 points. A byte represents the value of a point. 128 points are needed to draw a complete waveform. Data is transferred from low to high, where the first byte represents the first point, and so on.

Table A- 8 Read the waveform data of the device

Register Address	Byte	Description	Remark	Data Attribute
0x0500	128	L1 Grid Voltage Waveform		
0x0540	128	L2 Grid Voltage Waveform		
0x0580	128	L3 Grid Voltage Waveform		
0x05C0	128	L1 Load Current Waveform		
0x0600	128	L2 Load Current Waveform		
0x0640	128	L3 Load Current Waveform		
0x0680	128	L1 Comp Current Waveform		
0x06C0	128	L2 Comp Current Waveform		
0x0700	128	L3 Comp Current Waveform		
0x0740	128	L1 Grid Current Waveform		
0x0780	128	L2 Grid Current Waveform		
0x07C0	128	L3 Grid Current Waveform		

READ THE WAVEFORM DATA OF THE DEVICE (HISTOGRAM)

Function Code = 03, 04 Register Start Address = 0x0B00

A complete histogram consists of 60 points, one byte representing the value of one point, and only needs to be transmitted once. Data is transferred from low to high, where the first byte represents the first point, and so on.

Table A- 9 Read the waveform data of the device

Register Address	Byte	Description	Remark	Data Attribute
0x0B00	80	L1 Grid THDU Histogram		
0x0B28	80	L2 Grid THDU Histogram		
0x0B50	80	L3 Grid THDU Histogram		
0x0B78	80	L1 Load THDI Histogram		
0x0BA0	80	L2 Load THDI Histogram		
0x0BC8	80	L3 Load THDI Histogram		
0x0BF0	80	L1 Grid THDI Histogram		
0x0C18	80	L2 Grid THDI Histogram		
0x0C40	80	L3 Grid THDI Histogram		

ACQUIRE INFORMATION OF MANUFACTURER

Function Code = 03, 04

Register Start Address = 0x1000

Table A- 10 Acquire Information of Manufacturer

Register Address	Byte	Description	Remark
0x1000	2	Protocol Version	In decimal form E.g. 100 means V100 protocol.
0x1001	2	Software Version	In decimal form upper 12bits represent main version lower 4 bits represent branch version. E.g. 0x0641 means that main version is 100 and branch version is 01
0x1002	2	Device Address	1~247
0x1003	2	Reserved	

READ INFORMATION OF MONITOR MANUFACTURER

Function Code 03, 04

Register Start Address = 0x1200

Table A- 11 Read Information of Monitor Manufacturer

Register Address	Byte	Name	Remark
0x1200	2	Protocol Version	In decimal form E.g. 100 means V100 protocol.
0x1201	2	Software Version	In decimal form upper 12bits represent main version lower 4 bits represent branch version. E.g. 0x0641 means that main version is 100 and branch version is 01
0x1202	2	Device Address	1~247
0x1203	2	Reserved	
0x1204	2	Dry contact input	From low to high, every bit respectively represents dry contact input 1, dry contact input 2 and so on. 1: High level 0: Low level
0x1205	2	Dry contact output	From low to high, every bit respectively represents dry contact output 1, dry contact output 2 and so on. 1: High level 0: Low level

ACQUIRE PARAMETERS OF DEVICE (GENERAL SETTINGS)

Function Code = 03, 04
Register Start Address = 0x2000

Table A- 12 Acquire Parameters of Device (General Settings)

Register Address	Byte	Description	Remark
Initialization			
0x2000	4	Number of Slave	[1-10] Default: 1
0x2002	4	CT ratio	[0, 30000] Default: 300 (Issue DSP module restart)
0x2004	4	External transformer ratio	[0.1, 75] Default: 1.0 (Issue DSP module restart)
0x2006	4	Parallel Machine Capacity	[10, 30000] Default: 25 (Issue DSP module restart)
0x2008	4	Reserved	
0x200A	4	Reserved	
0x200C	4	Harmonic Compensation Rate setting	[0.01, 1] Default: 1
0x200E	4	Target Power Factor setting	[-1, 1] Default: 1
0x2010	4	Reserved	
0x2012	4	Reserved	
0x2014	4	Reserved	
0x2016	4	Reserved	
0x2018	4	Reserved	
0x201A	4	Reserved	
0x201C	4	Working Mode	Default: 0 (Harmonic Compensation) For details, please refer to Appendix II.
0x201E	4	Power On Mode	0: Auto 1: Manual Default: 1
0x2020	4	Compensation Mode	0: Intelligent 1: Sequential 2: All Default: 1 (Issue DSP module restart)
0x2022	4	CT location	0: Grid 1: Load Default: 1 (Issue DSP module restart)
0x2024	4	Three-phase three-wire/ Three-phase four-wire system	0: 3P4W 1: 3P3W Default: 0 (Issue DSP module restart)
0x2026	4	Reserved	
0x2028	4	CT Secondary Wiring	0: Series 1: Parallel Default: 0 (Issue DSP module restart)
0x202A	4	Reserved	
0x202C	4	Inductance Current Calibration Process	0: Capacitive Current Calibration 1: Inductive Current Calibration Default: 0 (Issue DSP module restart)

0x202E	4	Input Frequency Level	0: 50Hz 1: 60Hz Default: 50Hz
0x2030	4	PPL Enable	1: Disable 0: Enable Default: 1
0x2032	4	Input Current Abnormal Enable	1: Disable 0: Enable Default: 1
0x2034	4	Reserved	
0x2036	4	Temperature Derating Enable	1: Disable 0: Enable Default: 1
0x2038	4	Capacitive Reactive Power Compensation Enable	1: Disable 0: Enable Default: 1
0x203A	4	Reserved	
0x203C	4	Reserved	
0x203E	4	Grid Voltage Adjustment Enable	1: Disable 0: Enable Default: 1
0x2040	4	Reserved	
0x2042	4	Reserved	
0x2044	4	Reserved	
0x2046	4	Target voltage	[100V, 700V] Default: 230V Accuracy: 0.1
0x2048	4	Reserved	
0x204A	4	Reserved	
0x204C	4	Reserved	
0x204E	4	Reserved	
0x2050	4	Reserved	
0x2052	4	Reserved	
0x2054	4	Constant reactive	[-3000.0, 3000.0] Default: 1 Accuracy: 0.1
0x2056	4	Voltage Upper Limit (%)	[0, 20%] Default: 7%
0x2058	4	Voltage Lower Limit (%)	[-20%, 0] Default: 10%
0x205A	4	Reserved	
0x205C	4	THDu Limit (%)	[0, 50] Default: 0 Advanced
0x205E	4	Un!!!balance!!! Limit	[0, 1] Default: 0 Advanced
0x2060	4	Reactive Power Tracking Control Value	[-3000.0, 3000.0] Default: 0 Accuracy: 0.1 Generally
0x2062	4	Reserved	
0x2064	4	Reserved	
0x2066	4	Reserved	
0x2068	4	Reserved	
0x206A	4	Low Load Energy-saving Shutdown Mode	[0.0, 100.0] (0 means disable) Default: 0 Accuracy: 0.1
0x206C	4	Reserved	
0x206E	4	Reserved	

ACQUIRE PARAMETERS OF DEVICE (PARAMETER OF PHASE ANGLE OFFSET)

Function Code = 03, 04
Register start address = 0x2500

Table A- 13 Acquire Parameters of Device (Parameter of Phase Angle Offset)

Register Address	Byte	Name	Remark
Initialization			
0x2500	4	Fundamental phase angle offset	[-40, 40] Accuracy: 0.1 Default: 0
0x2502	4	3rd harmonic phase angle offset	[-180, 180] Accuracy: 0.1 Default: 0
0x2504	4	5th harmonic phase angle offset	[-180, 180] Accuracy: 0.1 Default: 0
0x2506	4	7th harmonic phase angle offset	[-180, 180] Accuracy: 0.1 Default: 0
0x2508	4	9th harmonic phase angle offset	[-180, 180] Accuracy: 0.1 Default: 0
0x250A	4	11th harmonic phase angle offset	[-180, 180] Accuracy: 0.1 Default: 0
0x250C	4	13th harmonic phase angle offset	[-180, 180] Accuracy: 0.1 Default: 0
0x250E	4	L1 phase angle offset	[-180, 180] Accuracy: 0.01 Default: 0
0x2510	4	L2 phase angle offset	[-180, 180] Accuracy: 0.01 Default: 0
0x2512	4	L3 phase angle offset	[-180, 180] Accuracy: 0.01 Default: 0
0x2514	4	2se harmonic phase angle offset	[-180, 180] Accuracy: 0.01 Default: 0
0x2516	4	4th harmonic phase angle offset	[-180, 180] Accuracy: 0.01 Default: 0
0x2518	4	6th harmonic phase angle offset	[-180, 180] Accuracy: 0.01 Default: 0
0x251A	4	8th harmonic phase angle offset	[-180, 180] Accuracy: 0.01 Default: 0
0x251C	4	10th harmonic phase angle offset	[-180, 180] Accuracy: 0.01 Default: 0
0x251E	4	12th harmonic phase angle offset	[-180, 180] Accuracy: 0.01 Default: 0
0x2520	4	14th harmonic phase angle offset	[-180, 180] Accuracy: 0.01 Default: 0
0x2522	4	15th harmonic phase angle offset	[-180, 180] Accuracy: 0.01 Default: 0

Sinexcel

0x2524	4	16th harmonic phase angle offset	[-180, 180] Accuracy: 0.01 Default: 0
0x2526	4	17th harmonic phase angle offset	[-180, 180] Accuracy: 0.01 Default: 0
0x2528	4	18th harmonic phase angle offset	[-180, 180] Accuracy: 0.01 Default: 0
0x252A	4	19th harmonic phase angle offset	[-180, 180] Accuracy: 0.01 Default: 0
0x252C	4	20th harmonic phase angle offset	[-180, 180] Accuracy: 0.01 Default: 0
0x252E	4	21th harmonic phase angle offset	[-180, 180] Accuracy: 0.01 Default: 0
0x2530	4	22th harmonic phase angle offset	[-180, 180] Accuracy: 0.01 Default: 0
0x2532	4	23th harmonic phase angle offset	[-180, 180] Accuracy: 0.01 Default: 0
0x2534	4	24th harmonic phase angle offset	[-180, 180] Accuracy: 0.01 Default: 0
0x2536	4	25th harmonic phase angle offset	[-180, 180] Accuracy: 0.01 Default: 0
0x2538	4	26th harmonic phase angle offset	[-180, 180] Accuracy: 0.01 Default: 0
0x253A	4	27th harmonic phase angle offset	[-180, 180] Accuracy: 0.01 Default: 0
0x253C	4	28th harmonic phase angle offset	[-180, 180] Accuracy: 0.01 Default: 0
0x253E	4	29th harmonic phase angle offset	[-180, 180] Accuracy: 0.01 Default: 0
0x2540	4	30th harmonic phase angle offset	[-180, 180] Accuracy: 0.01 Default: 0
0x2542	4	31th harmonic phase angle offset	[-180, 180] Accuracy: 0.01 Default: 0
0x2544	4	32th harmonic phase angle offset	[-180, 180] Accuracy: 0.01 Default: 0
0x2546	4	33th harmonic phase angle offset	[-180, 180] Accuracy: 0.01 Default: 0
0x2548	4	34th harmonic phase angle offset	[-180, 180] Accuracy: 0.01 Default: 0
0x254A	4	35th harmonic phase angle offset	[-180, 180] Accuracy: 0.01 Default: 0
0x254C	4	36th harmonic phase angle offset	[-180, 180] Accuracy: 0.01 Default: 0

Sinexcel

0x254E	4	37th harmonic phase angle offset	[-180, 180] Accuracy: 0.01 Default: 0
0x2550	4	38th harmonic phase angle offset	[-180, 180] Accuracy: 0.01 Default: 0
0x2552	4	39th harmonic phase angle offset	[-180, 180] Accuracy: 0.01 Default: 0
0x2554	4	40th harmonic phase angle offset	[-180, 180] Accuracy: 0.01 Default: 0
0x2556	4	41th harmonic phase angle offset	[-180, 180] Accuracy: 0.01 Default: 0
0x2558	4	42th harmonic phase angle offset	[-180, 180] Accuracy: 0.01 Default: 0
0x255A	4	43th harmonic phase angle offset	[-180, 180] Accuracy: 0.01 Default: 0
0x255C	4	44th harmonic phase angle offset	[-180, 180] Accuracy: 0.01 Default: 0
0x255E	4	45th harmonic phase angle offset	[-180, 180] Accuracy: 0.01 Default: 0
0x2560	4	46th harmonic phase angle offset	[-180, 180] Accuracy: 0.01 Default: 0
0x2562	4	47th harmonic phase angle offset	[-180, 180] Accuracy: 0.01 Default: 0
0x2564	4	48th harmonic phase angle offset	[-180, 180] Accuracy: 0.01 Default: 0
0x2566	4	49th harmonic phase angle offset	[-180, 180] Accuracy: 0.01 Default: 0
0x2568	4	50th harmonic phase angle offset	[-180, 180] Accuracy: 0.01 Default: 0

ACQUIRE PARAMETERS OF DEVICE (HARMONIC COMPENSATION PARAMETERS)

Function Code = 03, 04

Register start address = 0x2A00

Table A- 14 Acquire Parameters of Device (harmonic Compensation Parameters)

Register Address	Byte	Name	Remark
Initialization			
0x2A00	4	2nd harmonic compensation degree	[0, 110] Default: 0
0x2A02	4	3rd harmonic compensation degree	[0, 110] Default: 0
0x2A04	4	4th harmonic compensation degree	[0, 110] Default: 0
0x2A06	4	5th harmonic compensation degree	[0, 110] Default: 0
0x2A08	4	6th harmonic compensation degree	[0, 110] Default: 0
0x2A0A	4	7th harmonic compensation degree	[0, 110] Default: 0
0x2A0C	4	8th harmonic compensation degree	[0, 110] Default: 0
0x2A0E	4	9th harmonic compensation degree	[0, 110] Default: 0
0x2A10	4	10th harmonic compensation degree	[0, 110] Default: 0
0x2A12	4	11th harmonic compensation degree	[0, 110] Default: 0
0x2A14	4	12th harmonic compensation degree	[0, 110] Default: 0
0x2A16	4	13th harmonic compensation degree	[0, 110] Default: 0
0x2A18	4	14th harmonic compensation degree	[0, 110] Default: 0
0x2A1A	4	15th harmonic compensation degree	[0, 110] Default: 0
0x2A1C	4	16th harmonic compensation degree	[0, 110] Default: 0
0x2A1E	4	17th harmonic compensation degree	[0, 110] Default: 0
0x2A20	4	18th harmonic compensation degree	[0, 110] Default: 0
0x2A22	4	19th harmonic compensation degree	[0, 110] Default: 0
0x2A24	4	20th harmonic compensation degree	[0, 110] Default: 0
0x2A26	4	21st harmonic compensation degree	[0, 110] Default: 0
0x2A28	4	22nd harmonic compensation degree	[0, 110] Default: 0
0x2A2A	4	23rd harmonic compensation degree	[0, 110] Default: 0
0x2A2C	4	24th harmonic compensation degree	[0, 110] Default: 0
0x2A2E	4	25th harmonic compensation degree	[0, 110] Default: 0
0x2A30	4	26th harmonic compensation degree	[0, 110] Default: 0
0x2A32	4	27th harmonic compensation degree	[0, 110] Default: 0
0x2A34	4	28th harmonic compensation degree	[0, 110] Default: 0

Sinexcel

0x2A36	4	29th harmonic compensation degree	[0, 110] Default: 0
0x2A38	4	30th harmonic compensation degree	[0, 110] Default: 0
0x2A3A	4	31st harmonic compensation degree	[0, 110] Default: 0
0x2A3C	4	32nd harmonic compensation degree	[0, 110] Default: 0
0x2A3E	4	33rd harmonic compensation degree	[0, 110] Default: 0
0x2A40	4	34th harmonic compensation degree	[0, 110] Default: 0
0x2A42	4	35th harmonic compensation degree	[0, 110] Default: 0
0x2A44	4	36th harmonic compensation degree	[0, 110] Default: 0
0x2A46	4	37th harmonic compensation degree	[0, 110] Default: 0
0x2A48	4	38th harmonic compensation degree	[0, 110] Default: 0
0x2A4A	4	39th harmonic compensation degree	[0, 110] Default: 0
0x2A4C	4	40th harmonic compensation degree	[0, 110] Default: 0
0x2A4E	4	41st harmonic compensation degree	[0, 110] Default: 0
0x2A50	4	42nd harmonic compensation degree	[0, 110] Default: 0
0x2A52	4	43rd harmonic compensation degree	[0, 110] Default: 0
0x2A54	4	44th harmonic compensation degree	[0, 110] Default: 0
0x2A56	4	45th harmonic compensation degree	[0, 110] Default: 0
0x2A58	4	46th harmonic compensation degree	[0, 110] Default: 0
0x2A5A	4	47th harmonic compensation degree	[0, 110] Default: 0
0x2A5C	4	48th harmonic compensation degree	[0, 110] Default: 0
0x2A5E	4	49th harmonic compensation degree	[0, 110] Default: 0
0x2A60	4	50th harmonic compensation degree	[0, 110] Default: 0
0x2A62	4	Reserved	
0x2A64	4	Reserved	
0x2A66	4	Reserved	
0x2A68	4	Reserved	
0x2A6A	4	Reserved	
0x2A6C	4	Reserved	
0x2A6E	4	Reserved	
0x2A70	4	Reserved	
0x2A72	4	Reserved	
0x2A74	4	Reserved	
0x2A76	4	Reserved	

ACQUIRE PARAMETERS OF DEVICE (NO INITIALIZATION)

Function Code = 03, 04
 Register start address = 0x2C00
 End address = 0x30ff

Table A- 15 Acquire Parameters of Device (No Initialization)

Register address	Byte	Name	Remark
No initialization			
0x2C00	4	L1 Input Voltage Calibration	Greater than 0
0x2C02	4	L2 Input Voltage Calibration	Greater than 0
0x2C04	4	L3 Input Voltage Calibration	Greater than 0
0x2C06	4	Reserved	
0x2C08	4	L1 Inductance Current Calibration	Greater than 0
0x2C0A	4	L2 Inductance Current Calibration	Greater than 0
0x2C0C	4	L3 Inductance Current Calibration	Greater than 0
0x2C0E	4	L1 CT Current Calibration	Greater than 0
0x2C10	4	L2 CT Current Calibration	Greater than 0
0x2C12	4	L3 CT Current Calibration	Greater than 0
0x2C14	4	L1 Inverter Current Calibration	Greater than 0
0x2C16	4	L2 Inverter Current Calibration	Greater than 0
0x2C18	4	L3 Inverter Current Calibration	Greater than 0
0x2C1A	4	Clear Fault	Pass 1
0x2C1C	4	CT Zero Point Calibration Enable	Pass 1 (Issue DSP module restart)
0x2C1E	4	Power On	Pass 1
0x2C20	4	Power Off	Pass 1
0x2c22	4	Reserved	
0x2c24	4	Reserved	
0x2c26	4	Reserved	

READ THE PARAMETERS OF THE DEVICE (EACH HARMONIC COMPENSATION MODE)

A mode is composed of three parameters. The value of each bit represents whether the mode is selected for the first harmonic. 1 means selection, 0 means no selection.

Table A- 16 Read the parameters of the device (each harmonic compensation mode)

Register address	Byte	Name	Remark
Initialization			
0x3200	4	2se~24th harmonic compensation mode 1	Default 0x7FFFFFFF
0x3202	4	25th~47th harmonic compensation mode 1	Default 0x7FFFFFFF
0x3204	4	48th~61th harmonic compensation mode 1	Default 0x7
0x3206	4	2se~24th harmonic compensation mode 2	Default 0
0x3208	4	25th~47th harmonic compensation mode 2	Default 0
0x320A	4	48th~61th harmonic compensation mode 2	Default 0
0x320C	4	2se~24th harmonic compensation mode 3	Default 0
0x320E	4	25th~47th harmonic compensation mode 3	Default 0
0x3210	4	48th~61th harmonic compensation mode 3	Default 0

SETTING PARAMETERS OF DEVICE

The parameter setting value is a floating point number. It is represented by 4 bytes. Therefore, the function code 16 is used to set a single parameter and a plurality of parameters, including general parameters, phase angle offset parameters, harmonic compensation parameters, and no initialization parameters.

ACQUIRE FAULT RECORD

Function Code: 03, 04

Register start address = 0xf000

SINEXCEL MODBUS APPLICATION

MODBUS is an application layer protocol and is widely used in industrial control. It is the de facto industry standard. Sinexcel provides both MODBUS RTU and TCP/IP communication. RTU is realized by RS485 interface

and TCP/IP by Ethernet port. Using Modbus, customers can realize the following functions:

- Acquire the status and alarm information;
- Acquire data like analog value, waveform, histogram, and manufacturer information;
- Set the parameters of the device. For more details, please refer to the Sinexcel Modbus protocol.

Physical Connection

Following is instructions on establishing connection between PC and modules via MODBUS

MODBUS TCP/IP

For LCD modules, Ethernet connection is optional. An extra dry contact board is needed. For 7-inch HMI, the Ethernet port is on the side of it. Ethernet connection has two types:

- ① Monitor connects with PC directly via reticle

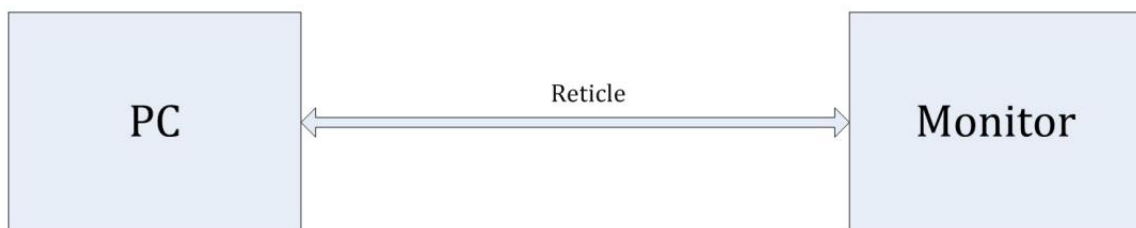

Figure A- 49 Monitor connects with PC directly via reticle

1. Make sure the reticle is firmly connected with the monitor. After the reticle is successfully connected, the green LED.

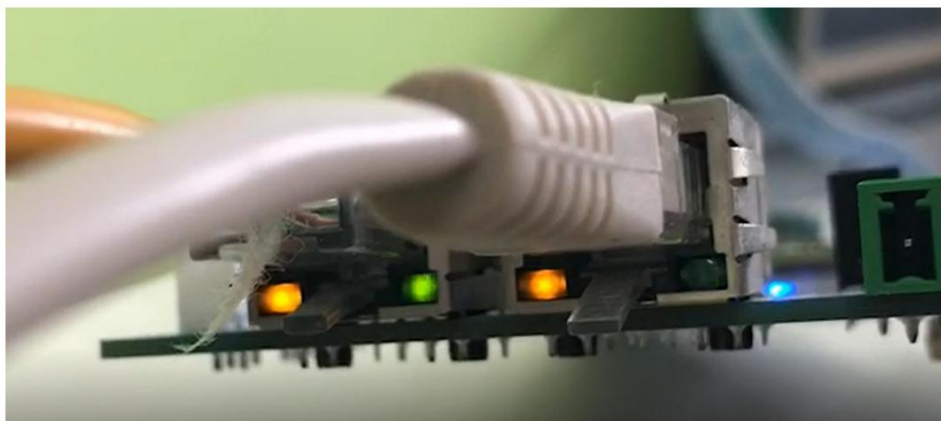

Figure A- 50 Connecting

2. Set the IP address and Subnet Mask manually on the monitor. Make sure they are on the same network segment with the PC.

3. Ping the address.

4. After successfully Ping the address, use the software modbuspoll for debugging. To establish the connection, the IP address should be the one of monitor and the

Sinexcel

② Monitor connects with PC via router

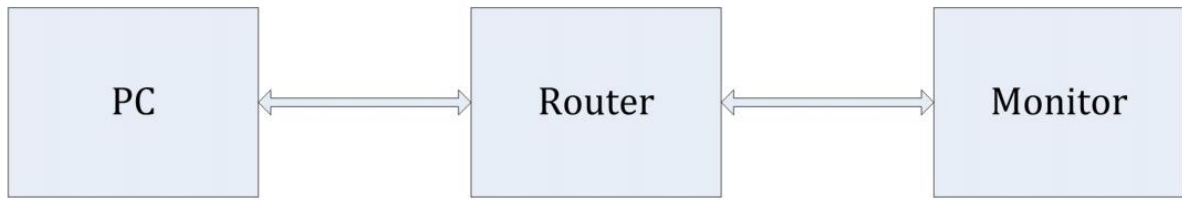

Figure A- 51 Monitor connects with PC via router

1. Make sure the reticle is firmly connected with the monitor. After the reticle is successfully connected, the green LED light on the port will flicker.
2. The router will assign IP address to PC automatically. Set the IP address, Mask and gateway manually on the monitor and make sure they are on the same Network segment as the ones of PC.
3. Ping the address.
4. After successfully Ping the address, use the software modbuspoll for debugging. To establish the connection, the IP address should be the one of monitor and the port should be 1025.

MODBUS RTU

RS485 is a standard function for all Sinexcel products. For single units, RS485 interfaces are on the back side. For the 7-inch HMI, they're on the right side, and 485_A7 and 485_B7 are for remote control.

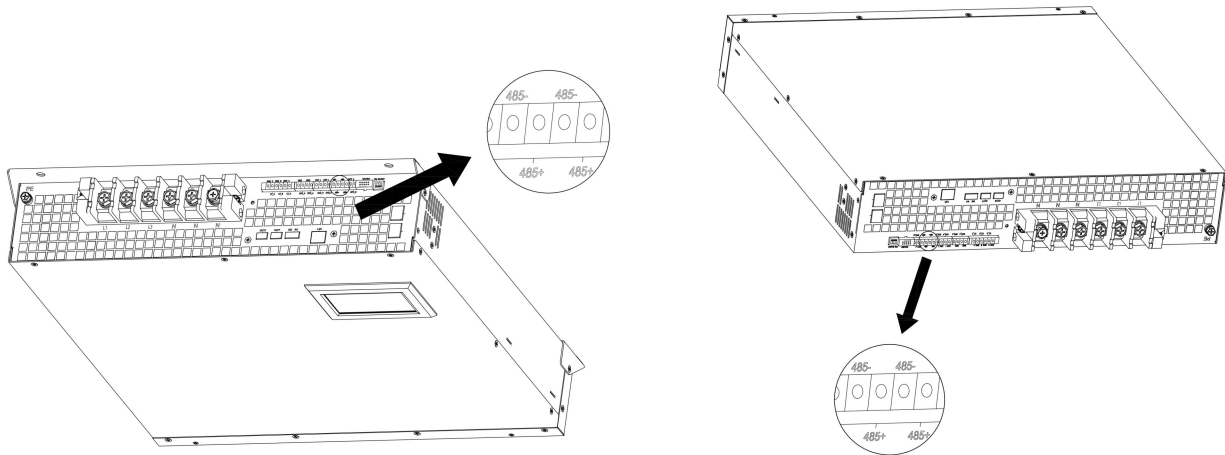

Figure A- 52 Single Module Unit

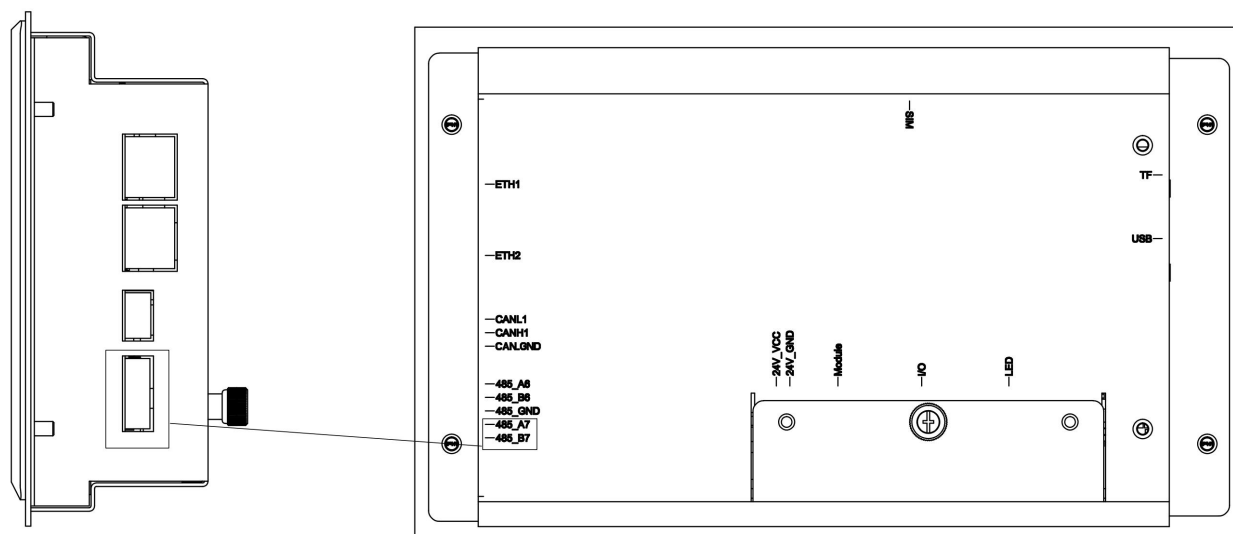

Figure A- 53 7-inch HMI

If were to connect with PC, an adapter is needed, like 485 to 232 adatper or 485 to USB adapter. Monitor connects with PC via adapter.

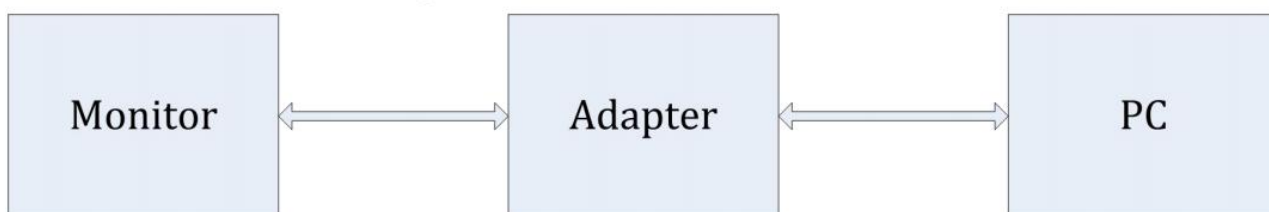

Figure A- 54 Connecting

1. Make sure devices are firmly connected.
2. Set the Baud rate on the monitor.
3. Use instrument like modbuspoll for commission. The Baud rate should match the one set on the monitor. The port should match the one the unit is connected to, which is shown

INTERFACE & DIMENSIONS

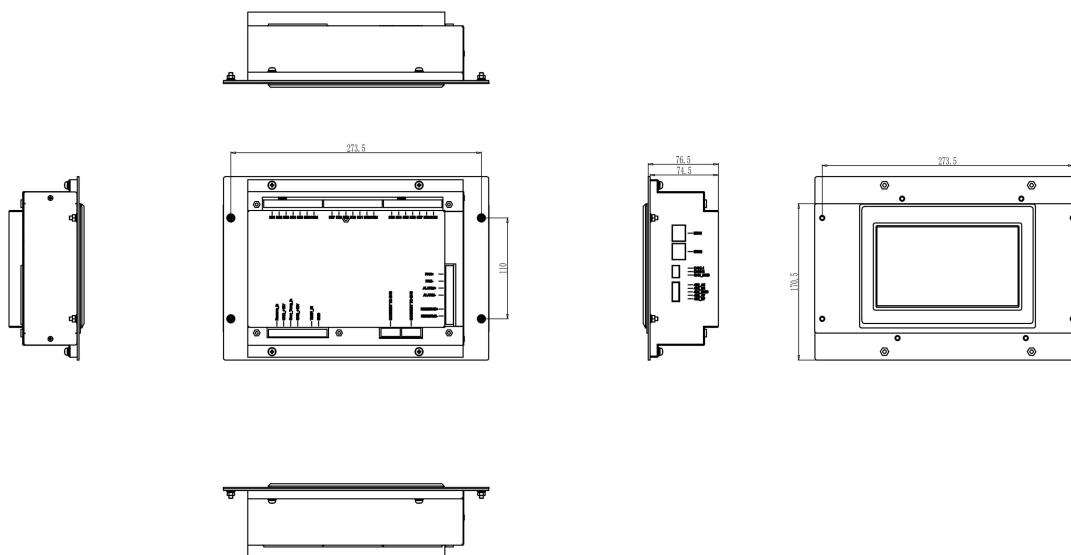

Figure A- 55 Dimensions of ICMS-P2

Sinexcel ICMS-P2, which the size is W273.5*D76.5*H170.5mm.

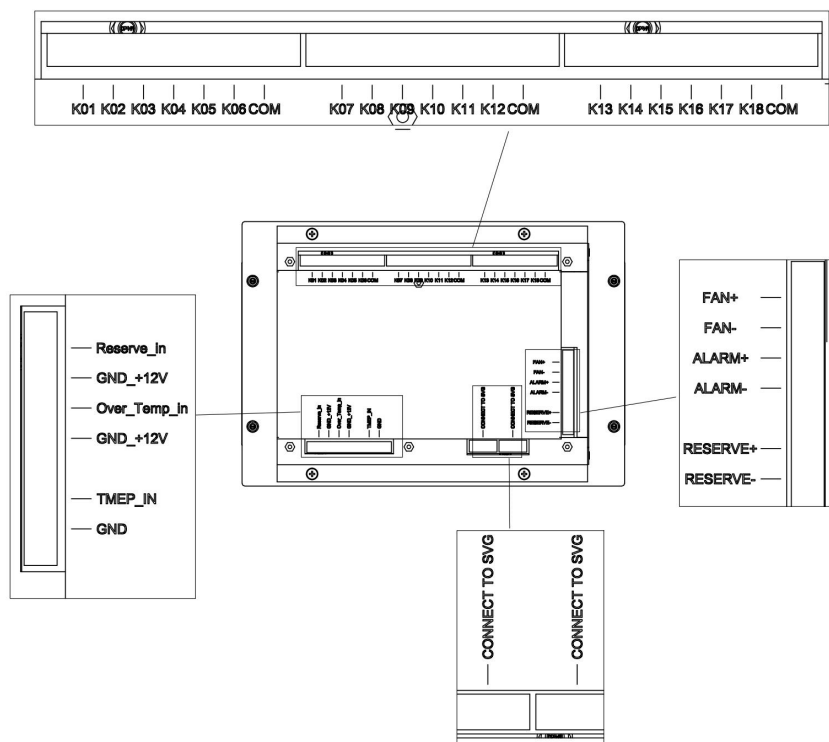

Figure A- 56 Structure of ICMS-P2

ICMS-P2 INTRODUCTION

Sinexcel ICMS is a special 7-inch HMI that is able to control both SVG and capacitor bank, offers the more cost effective solution for the customer. Reactive power generated by load will be compensated by SVC at first and the rest of the reactive power will be compensated accurately in real time basis by SVG. In this way, the whole system is able to remain in low cost but it is able to compensate the reactive power in 15ms.

Functional characteristics

Control signals: adopt power factor target parameter control

Way number in common use: switching way number (separately compensated or jointly compensated) is determined by users

Data storage: parameters do not lose after power-off; namely, data can be saved permanently

Over-voltage protection: in the case that grid voltage exceeds set voltage, the ICMS can rapidly switch off the capacitors

Strong anti-interference: with unique design, phenomena will not occur such as system halted or switching in disorder

Switching vibration: may prevent repeated switching caused by low-current load and over-voltage critical value

High sensitivity: a compensation may work normally when input signal current reaches 0.10A

Display error: when input signal current changes from 0.10A to 5A, error of power factors displayed and measured will not exceed $\pm 1\%$

SERVICE ENVIRONMENT

Ambient temperature: not higher than $+60^{\circ}\text{C}$, and not lower than -25°C Humidity: $\leq 95\%$, without condensation

Altitude: not more than 2,500 m

Environmental conditions: there is no flammable and combustible medium existing, no corrosive gas, no conductive dust and corrosion of snow and rain; meanwhile, there is no violent vibration occurring at the location of installation.

Storage temperature: not higher than 70°C , and not lower than -40°C

ICMS-P2 DEFINITION

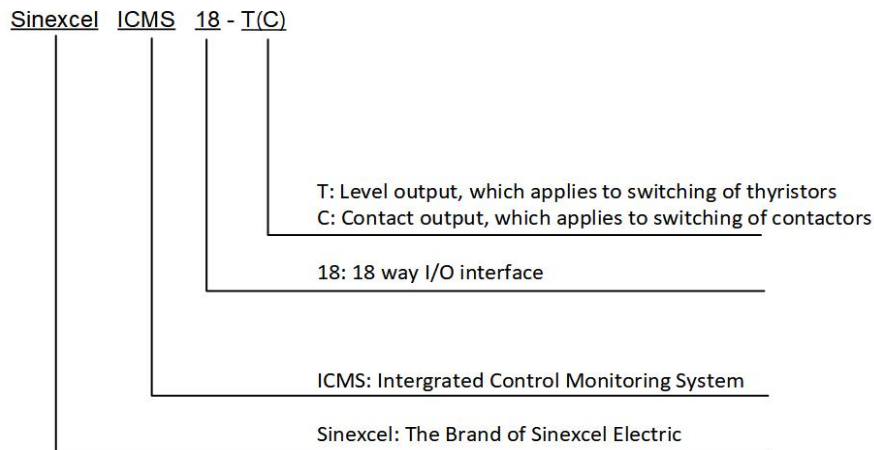

Figure A- 57 ICMS-P2 Nameplate

ICMS-P2 FUNCTION

Sinexcel ICMS is equipped with a 7-inch color touch screen, which serves as the center of monitoring and setting. High performance control unit is embedded in the monitoring module. Thus, the module has abundant functions such as real-time data acquisition, storage, real-time control, USB, etc. It can also provide abundant human-computer interaction interfaces, so that users may read data about voltage, current, and $\text{COS } \phi$ via the interfaces. To facilitate users to read data about voltage and current, the monitoring module provides them with voltage and current waveform display function as well.

Real-time data monitoring

The monitoring interface supplies users with real-time information about system, grid, SVG, and CT as well as information about the switching status of capacitors, as shown in Fig. 5.1, 5.2, 5.3, 5.4, and 5.5.

System: voltage, current, active power, reactive power, and $\text{COS } \phi$ in phase L1, phase L2, and PhaseC

Grid side: voltage, current, power factor, THDU, THDI, system frequency, active power, reactive power, and $\text{COS } \phi$ in phase L1/ L2/L3

SVG: offset current, load ratio, IGBT temperature, and machine capacity in phase L1/ L2/ L3

CT (load) side: current, THDI, active power, reactive power, and $\text{COS } \phi$ in phase L1/L2/ L3

Capacitors: setting parameters for switching of capacitors



Figure A- 58 System interface

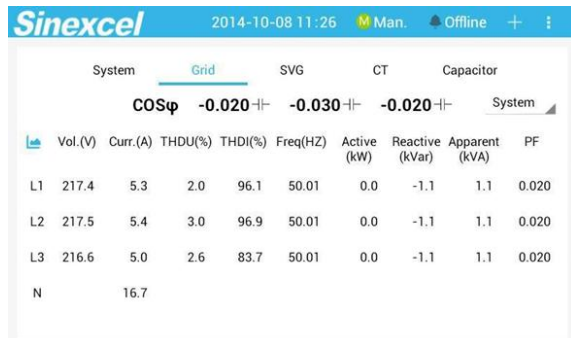

Figure A- 59 Grid Information

Sinexcel

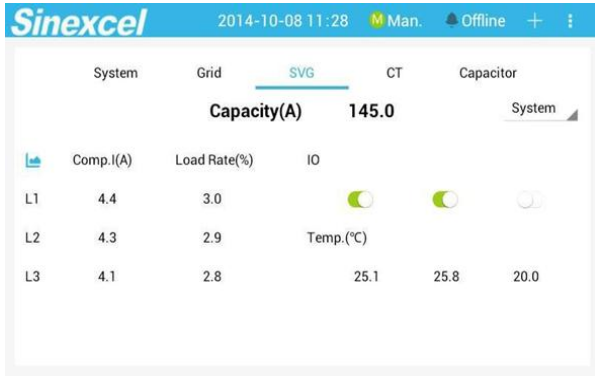

Figure A- 60 SVG parameter information



Figure A- 61 Load information



Figure A- 62 Capacitor settings information

Waveform display

Click waveform sign, which can read grid voltage, grid current, load current, offset current, grid THDU, grid THDI, and load THDI waveform, as shown in Fig.5.6 and 5.7.

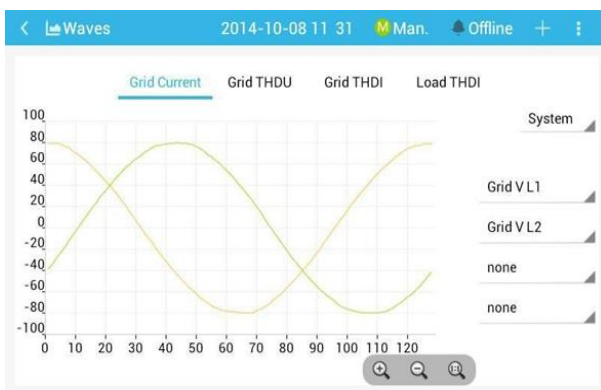

Figure A- 63 Voltage and current waveform

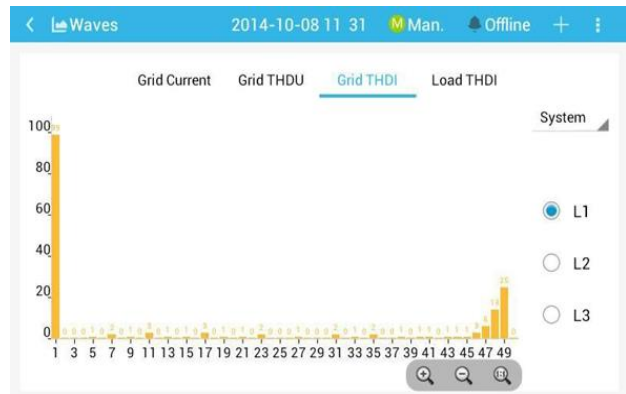

Figure A- 64 Grid THDI Waveform

Recording and analyzing of historical data

The monitoring module of Sinexcel ICMS can store historical data; namely, it can save data at the time of power down. Users may click at the top panel and then click “record”, check the current alarm, historical alarm, operation record of ICMS, switching times, operation time and operation data of each capacitor.

Records 2014-10-08 11:29 Man. Offline

Active History Operations Capacitor

S/N	Module	Alarm Name	Start Time
1	SVG#1	Monitor Setting Error	2014-10-08 11:18:51
2	SVC	Communication Failure	2014-10-08 11:18:45

Figure A- 65 Current alarm interface

Records 2014-10-08 11:30 Man. Offline

Active History Operations Capacitor

S/N	Module	Alarm Name	Start Time	End Time
1	SVC	Communication Failure	2014-10-08 11:00:30	-----
2	SVG#1	Communication Failure	2014-10-08 11:00:21	-----
3	SVC	Communication Failure	2014-09-30 14:09:27	-----
4	SVG#1	Communication Failure	2014-09-30 14:09:18	-----
5	SVC	Communication Failure	2014-09-30 14:08:15	-----
6	SVG#1	Communication Failure	2014-09-30 14:08:06	-----

Figure A- 66 Historical alarm interface

Records 2014-10-08 11:30 Man. Offline

Active History Operations Capacitor

S/N	Module	Operation Type	Start Time	Initial Value	End Value
-----	--------	----------------	------------	---------------	-----------

Figure A- 67 Operating Record Interface

Records 2014-10-08 11:30 Man. Offline

Active History Operations Capacitor

S/N	Module	Operation Type	Start Time	Initial Value	End Value
-----	--------	----------------	------------	---------------	-----------

Figure A- 68 Capacitor switching times and operating time

Data management

Via the USB Interface arranged on the controller, users may export recorded data with a USB flash disk. The exported file belongs to txt file. Open it in Excel on PC for data analysis. After entering the main record interface, click the "data statistics" option, and then click the "export" option, and the data will be exported.

ICMS-P2 TECHNICAL PARAMETERS

BASIC PARAMETERS

The maximum power consumption of the complete machine: 25 W Output nodes of the level: 18 ways, with DC12V/30mA for each Output nodes of contacts: 120V AC/10A, 220V AC/8A, and 400V AC/3A

MEASUREMENT ACCURACY

Table A- 18 ICMS-P2 Measurement Accuracy

Item	ACCURACY Value
Voltage	±1%
Current	±1%
Frequency	±1%
Power Factor	±1%
Active Power	±1%
Reactive Power	±1%

CONTROL AND PROTECTION PARAMETER RANGE

Table A- 19 ICMS-P2 Control and protection parameter range

Parameter	Range	Adjust the step	Default	Remarks
Power Factor of System Target	-1~1	0.01	1.00	
Setting of voltage classes	380/480/690/1140	/	/	Options
Setting of grid frequency	50/60	/	/	Options
Setting of CT transformation ratio	150~10000	1	600	Secondary-side is 5A
Switching Delay	20ms~300s	1ms	20ms	/
THDU Overrun	5%~15%	0.1	7%	/
SVC Over-voltage Protection	5%~20%	1%	20%	Phase Voltage
SVC Under-voltage Protection	-30%~-5%	1%	-25%	For protection
The upper limit of frequency protection	0.5~5	0.1	2	For protection
The lower Limit of Frequency Protection	-5~-0.5	0.1	-1	For protection
Starting temperature of SVC Fan	20~100	1	20	/

EXTERNAL COMMUNICATION INTERFACE

Table A- 20 ICMS-P2 External Communication Interface

Communication Interface	Description of applications	Quantity
485 Communication Interface 1	External communication interface	1
USB Interface	Interface for code upgrade and data download	1

APPENDIX VII CABINET DESIGNING INSTRUCTIONS

CABINET COMPONENT LIST

When users need to design their own cabinets who need preparing the component list below:

Table A- 21 Cabinet component list

Item	Number	Note
power cable	According to design	
485 cable	According to design	
CT cable	According to design	
CT	According to the system wiring	
CT Terminals bar	1	
EPO Button	1	Sinexcel provide
Indicator(Red)	1	
Indicator(Green)	1	
7-inch HMI	1	
Module	Max. is 8	
MCCB(Breaker)	1	

For others customers can choose to buy on their own or from Sinexcel.

CABINET VENTILATION DESIGN

When users need to design their own cabinets, the cabinet ventilation design should meet the requirements of this article.

SVG module has fans inside for cooling, in order to meet the cooling requirement, the cabinet should leave enough ventilation area on the door. When there are no special requirements of the appearance and the IP class, air cooling design without fans should be first option for the cabinet ventilation design. Air cooling design should meet the following items:

- The effective ventilation area in the front door of the cabinet should be more than 1.5 times ventilation area in the front side of the module.
- The effective ventilation area in the rear door of the cabinet should not be more than 1.5 times ventilation area in the rear side of the module.

Module effective ventilation area: Each module has many ventilation holes in the front side, module ventilation area means the sum of all the ventilation holes' area in the front side. Similarly, ventilation area on the rear side of the module means the sum of all the ventilation holes' area in the rear side.

Effective ventilation area in the front door of the cabinet means the sum of the area of all the ventilation holes in the front door. Similarly, effective ventilation area in the rear door of the cabinet means the sum of the area of all the ventilation holes in the rear door.

- The position of the ventilation hole in the front and rear door of the cabinet should face the position of the module ventilation hole.

Sinexcel

Capacity	100K
Cooling (Smart ventilation)	240CFM

Cabinet Ventilation= Module cooling requirement *1.5

For example: User needs to build the 500K IP20 rear cabinet, which need to install the 5*100K Ultra SVG

Cabinet ventilation = (5*240CFM) *1.5=1800CFM

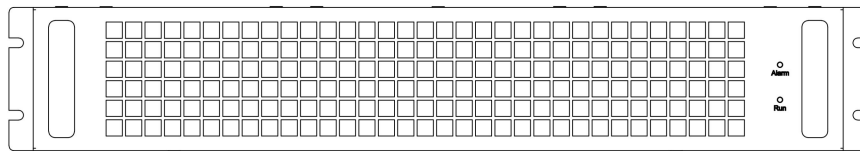

Figure A- 69 SVG ventilation holes on front side (air inlet)

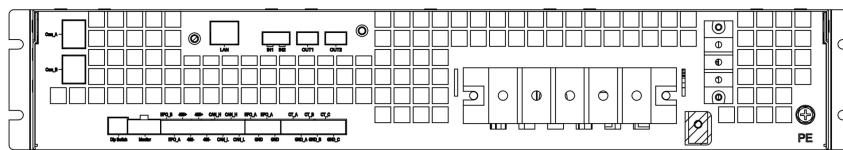

Figure A- 70 SVG ventilation holes on the rear side (air outlet)

- Above standards apply to IP2X or IP3X air cooling design cabinet, higher IP level cabinet may need to add fans to improve heat dissipation. If there are requirements of higher protection class cabinet, please contact Sinexcel.

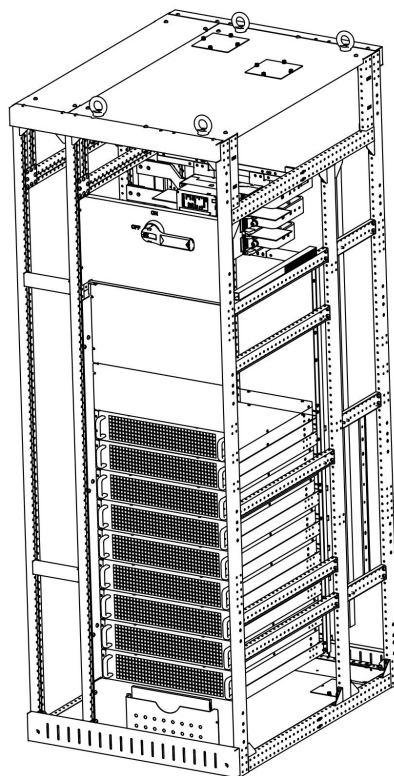

Figure A- 71 Structure of Sinexcel Rear Ventilation Cabinet

FAN-FORCED AIR COOLING

Sinexcel doesn't suggest user to design the cabinet with fans, which means the IP class of the cabinet is higher than IP5X.

When design the cabinet with fans inside for cooling, cabinet ventilation design should meet the following items:

- Open the ventilation hole in the front door, use fans to exhaust hot air in the rear. The effective ventilation area in the front door should not be less than 2.5 times the module ventilation area. The heat dissipation capacity of the fans in the rear side should be more than 2.5 times of the heat volume of all modules. The cooling requirement of single module please refer to user manual.
- Front and rear door both have fans. The heat dissipation capacity of the fans in the front and rear door should be more than 2.5 times the heat volume of the module.
- The installed position of fans should face the module ventilation hole as much as possible.

For fan-forced cooling cabinet that IP class is higher than IP5X, the drawing of the cabinet must be sent to Sinexcel engineer for confirmation. The following information is required:

- The appearance drawing of the cabinet and the structure drawing. The ventilation hole and fan install position can be clearly shown in the drawing.
- The cabinet with fans. The heat dissipation capacity of the fans is required.
- The cabinet with ventilation holes. The effective ventilation area is required.

Installing fans in cabinet to help vent is called fan-forced air cooling, 2 common design are listed below, and the following requirement should be followed:

- Natural air cooling on front side, fan-forced cooling on rear side.
- Cabinet's front ventilation area should not be less than 2.5 times the module's front ventilation area. The exhaust air volume of the fans in the rear should not be less than 2.5 times than summary heat volume of all modules. The cooling requirement of single module please refer user manual.
- Fan-forced air cooling on both front and rear side
- The exhaust air volume of the fans on front and rear door should both not be less than 2.5 times than summary heat volume of all modules.
- Cabinet's ventilation hole position should face against module ventilation hole position, and the fan's installing position should face against module's front or rear ventilation hole position.



APPENDIX VIII CURRENT TRANSFORMER

As one of external components of SVG, current transformer (CT) plays a key role in the normal operation of SVG, so the selection of external CT is extremely important. In 3-phase 3-wire system, two CTs are required, each installed on phase L1 and phase L3; while in 3-phase 4-wire system, three CTs are required, each installed on the circuits of phase L1, phase L2 and phase L3.

CT TYPE

SVG can use external CT ratio between 50:5~30000:5. Practical CT ratio should be selected within this range in accordance with actual load current. The setting of the CT ratio can be programmed into SVG via the settings during the commissioning phase.

Split-core or Solid-core CTs are both suitable for use. The accuracy of current transformer should be higher than 0.2 (Solid-core) or 0.5 (Split-core). Lower degree of accuracy may affect the compensation accuracy.

 Caution	Before power on, check if the CT ratio of the external CT is correct according to the settings in the touch screen. If not, SVG will not operate correctly.
 Caution	The CT primary should be selected to be 1.5~4 times (mostly choose 2 times) of the actual load current. Too small may result in equipment alarm; too large may affect the compensation performance. If special needs, please contact Sinexcel.

CT CABLE

As an accessory of Sinexcel SVG system, CT cable may contain three groups of shielded twisted pair (STP): yellow + black, green + black and red + black, each group consisting of two cables, twisted in pair to constitute CT cable. When the external CT is connected and installed, the yellow twisted pair is connected to phase A, the green to phase B and the red to phase C. Take the yellow as example, yellow pair is connected to S1 of external CT1, and the black to S2 of external CT1, ensuring the same direction of current straight through CT. Otherwise it may fail to achieve effect of compensation.

For CT cable shorter than 15m, recommended sectional area is 2.5mm². From 15m to 30m, recommended sectional area is 4mm². Above 30m, please contact Sinexcel.

CT CONNECTION ON SECONDARY SIDE

When connecting the secondary CT cables to SVG module, for A phase the S1 terminal of the CT is connected to the CT_A marked terminal on SVG and the S2 terminal of the CT is connected to the CT_A_GND marked terminal of SVG. This is duplicated for each phase.

CT SIZING

The CT ratio selection should be 1.5~4 times to maximum load current.

CT VA BURDEN

INSTRUCTION

Current transformers (CT) are used for measuring current, and play a key role in the normal operation of Sinexcel Static Var Generator.

CT maintains an accurate ratio between the currents in its primary and secondary circuits over a defined range. The alternating current in the primary produces an alternating magnetic field in the core, which then induces an alternating current in the secondary.

CTs are specified by a specific current ratio from primary to secondary side. The rated secondary current is normally 1 or 5A. Sinexcel SVG is compatible with CTs with secondary side current of 1A or 5A.

MECHANICAL STRUCTURE

There are two main types of CTs.

Solid core CTs form a permanently enclosed core. Installing a solid-core CT requires disconnecting the wire to get it through the CT core. The benefit is that they are usually less expensive and can be more accurate. They are most often used for new installations.

Split-core CTs have an "opening" in the core that allows the CT to be opened and placed around the conductor without interrupting the wiring. Split-core CTs can be more expensive, but more convenient.

CT RATIO

Sinexcel SVG is compatible with CTs with secondary side current of 1A or 5A.

For the CT with secondary side current of 1A, the range of CT ratio Sinexcel SVG can support is 10/1~6000/1.

For the CT with secondary side current of 5A, the range of CT ratio Sinexcel SVG can support is 50/1~30000/1.

CT BURDEN

CT burden is the total resistance of the secondary side. The maximum CT burden will vary depending on the CT turns ratio, the desired CT output and the rated current of the sensor. The value of CT burden is given in the specification of CT.

CT burden is commonly expressed in one of two ways:

The total impedance (Ω)

The total VA

CT CABLE

When choosing the length of CT cable, it's need to consider the following factors

The total resistance of CT's secondary side (CT burden) (check CT spec)

The resistance of CT cable (Calculate based on the cable diameter)

The resistance between the 2 pins of SVG CT port (Sinexcel SVG/SVG is 4.3×10^{-3} VA)

When the total resistance of the two CT cables exceeds the CT burden, the accuracy of the CT will be reduced. The load on the conductor can be calculated by using the following formula to determine how far the conductor can be extended without affecting accuracy.

CONCLUSION

For the CT with the CT burden $\geq 5VA$

If CT cable $< 15m$, $2.5mm^2$, dual twisted pair CT cable is suggested.

If CT cable $> 15m$ but $< 30m$, $4mm^2$, dual twisted pair CT cable is suggested.

If CT cable $> 30m$, it is necessary to confirm whether the CT rated load is larger than the cable impedance.

CALCULATION

For the impedance calculation of the CT cable, please refer to the following calculation of the 100m CT cable.

$$R = \rho \frac{L}{S}$$

For example, calculate the CT cable impedance by below formula

R: the impedance of cable

ρ : copper resistivity L: cable length

S: cross-sectional area

$L=100m$, $S=4mm^2$, $\rho=0.0172\Omega \cdot mm^2/m$,

so $R=0.43$

So one round of CT cable impedance is $2 \cdot R=0.86\Omega$

The secondary side current of CT is 5A, but in fact the current should be less than 3.9A, otherwise SVG will show alarm because of SVG software setting.

So $P = I^2 R = 3.9^2 * 0.86 = 13.08VA$

Since the CT is short-circuit inside the SVG, so the impedance of SVG could be neglected.

Base on the calculation, as long as the CT burden is bigger than 13.08VA, then SVG could work normally.

THE VA BURDEN OF OUR SVG MODULE

Same as before calculation.

For our SVG/ SVG module, $L=20mm$, $S=2.5mm^2$ $\rho=0.0172\Omega \cdot mm^2/m$, So $R=1.4 \times 10^{-4}\Omega$, $2R=2.8 \times 10^{-4}\Omega$

So $P = I^2 R = 3.9^2 * 2.8 \times 10^{-4}\Omega = 4.3 \times 10^{-3}V$.

CT SPECIAL APPLICATION INSTALLATION

When doing both harmonic mitigation and reactive power compensation with SVG and SVG equipment, please notice that SVG installation point should be closer to the Load side than SVG as below figure shows.

APPENDIX VIII CABLE SIZING

Table A- 22 Sinexcel power cable sizing recommend table

Rated Capacity	30kVAr	50kVAr	100kVAr	200kVAr	300kVAr	400kVAr	500kVAr	600kVAr	700kVAr	800kVAr
Phase L1/L2/L3 mm2	25	25	50	70*2	120*2	185*2	240*2	185*3	240*3	300*3
Phase N mm2	25	25	50*3	95*2	150*2	240*2	185*3	240*3	500*3	500*3
PE cable mm2	16	16	25	70	120	185	240	95*3	185*2	240*2
Power terminal screw	M6/M8	M6/M8	M8	M10	M10	M12	M16	M16	M16	M16
Power cable tightening torque	108~132(kgf.cm)									
PE terminal screw	M8	M8	M8	M8	M8	M8	M8	M8	M8	M8
Rated current of Breaker	63A	100A	200A	400A	630A	800A	1000A	1250A	1600A	1600A
CT cable	Below 15m: RVVSP 2*2.5 mm2; 15m-30m: RVVSP 2*4 mm2; above 30m: contact Sinexcel									
Range of CT ratio	50/5~30000/5									
Remark	Use SVG rated current as the current in this table, it provides the reference for power cable, neutral cable, PE cable and breaker sizing. This table is only for reference of power cable sizing. For some countries, there is more redundancy required when sizing the cable. In some Europe country, almost 70% redundancy need to be considered when choosing the current. If there is requirement for cable temperature, the specification of cable needs to be expanded. The power terminal screw and PE terminal screw dimension and power cable tightening torque could be found in the table.									

Note:

- The cable size selection of N phase should 3 times to phase if the zero-sequence harmonic as a main part of total harmonic current
- The CT ratio selection should be 1.5~4 times to maximum load current
- The Rated current selection of breaker should be 1.25 times or above to SVG rated capacity
- Accuracy class 0.5 or 0.2 of CT is sufficient to the module.
- The above 100K are only recommended for module cable selection, and the rest recommended for cabinet cable selection.

POWER ON STEPS

	<p>WARNING Only after SVG is installed and commissioned by an engineer correctly and the external power switch has been closed, can the power on steps be executed.</p>
---	--

These power on steps are applicable to SVG when it is at off-position. Operation steps are as follows:

- i. Supply power to SVG by closing the breaker between the grid and SVG.
- ii. Close the breaker in the cabinet. The HMI starts to work. If the green running indicator light of main cabinet flicks, it will indicate that SVG is normally energised. In case of any failure, the red alarm indicator on the cabinet will be on.
- iii. When powered on and normal supply is established and if SVG has been set as 'Automatic power on' mode, the system SVG will power on automatically.
- iv. If it is set as 'manual power on' and after the monitoring screen has started upon the energising process, click 'power on' in the menu. After a normal soft power on, the system will switch on the power module.

POWER OFF STEPS

	<p>WARNING To prevent personal injury and in case of cabinet maintenance or opening after shutdown, disconnect all input switches. Conduct relevant measurements using a multimeter to ensure personal safety.</p>
---	---

Click power off in the menu to stop system immediately and enter the 'stop' state.

Note: In a stop state, the internal system and terminal are still electrified (live). When the power is not disconnected, any maintenance or opening the cabinet is strictly prohibited.

AUTO POWER ON

In case of abnormal grid voltage or frequency, SVG will automatically stop compensating current output and enter standby state (standby mode will not operate in case of power outage).

When the following conditions are met, SVG will automatically re-run and recover output.

- i. The utility power has recover to normal
- ii. Auto-power on has been enabled in Settings-General-Start mode;
- iii. Auto-power on delay is enabled (default: 10 sec)

Note: If the auto power-on feature of SVG isn't enabled, the user needs to manually start SVG using the touch/monitor screen.

EMERGENCY STOP

In the case of an abnormal function or output of SVG, press the EPO button on the front panel to turn off the module (for cabinet solution). Immediately disconnect the circuit breaker or isolation switch between SVG and the grid to cut off the system input power.

After pressing EPO and finishing troubleshooting, if all tests appear OK, re-press the EPO button and click on the monitor screen, select 'Clear fault', and perform the startup operations if there is no alarm sounding.

APPENDIX XI SINEXCEL COMMON FAULT DIAGNOSIS

For common failures some failures and alarms can be solved by the user on site. If it can't be resolved, please contact Sinexcel.

The failures caused by improper use, such as CT cable reverse, CT polarity error, power cable phase sequence error and parameter setting error, can be found by checking the data in the power on process. For poor compensation effect and no alarm information, please contact Sinexcel.

Table A- 23 Sinexcel Common Fault Diagnosis

Alarm	Common cause	Solution
Inverter short-circuit fault	Short-circuit, the current is beyond the tolerant range of IGBT	Contact Sinexcel engineer
Output current abnormal	The load current changes too fast Resonance	Check if the load current change fast when the alarm appears. If so, use password '654321' to enter the setting, change 'Comp. mode' to sequential, change 'Input current abnormal' to 'Disable' If the alarm is caused by resonance, please refer to resonance debugging manual and contact Sinexcel
Inverter overheat	Environment temperature is high Ventilation is blocked Fan is broken.	Check if the ambient temperature is over 40°C Check the air flow way of module Check whether all fans are working. Check whether the setting parameter 'Temperature derating' is enable.
CT ratio setting error	The load current is bigger than the rated current of CT CT wiring is wrong	Check whether we choose the correct size of CTs. Check the CT cable wiring
Inverter overload	The module faulty alarm Resonance	Try to click 'Clear Alarm' on the HMI to see if the alarm will disappear If the alarm is caused by resonance, please refer to resonance debugging manual and contact Sinexcel
Frequency abnormal	Input voltage frequency is beyond range [45Hz~62.5Hz] Frequency is over range. Faulty alarm	Check if the grid frequency is beyond the range: 45-62.5Hz Try to click 'Clear Alarm' on the HMI to see if the alarm will disappear
Input voltage abnormal	Voltage is beyond module tolerable range Wire connection error Fuse is broken	Check whether the voltage level is beyond the range of product. Check the connection of the power cable. If the voltage is normal and the cable connection is correct, please contact Sinexcel engineer, it might need to check the internal fuse
Input phase sequence error	Phase sequence connect wrong	Check the power terminal connection
Monitor parameter setting fault	CT location is wrong Total capacity setting is wrong	Check if the CT location setting is correct Check if the total capacity setting is correct
Emergency shutdown	Emergency button is pressed down The emergency button is normal closed type The connection of EPO is not correct. False alarm of monitor. The module is broken	Check if the emergency button is pressed down Check if the emergency button is normal closed type, if so, please change to normal open type Try to click 'Clear Alarm' on the HMI to see if the alarm will disappear If all things are fine, please contact Sinexcel engineer
Communication failure	RS485 cable connection is wrong Dip switch setting error	Check the cable connection of RS485 Check if the dip switch is correct

Sinexcel

	communication parameter setting is not correct Slaver modules are too many, communication delay. If the product has WIFI module inside, check if the local address setting is match with dip switch setting	Check the communication setting parameters on HMI (Local address, baud rate)
Offline fault	The dip switch setting error Internal cable wiring is not connected well.	Check the dip switch, change it to correspond number. The setting of dip switch could be referred to user manual if the dip switch setting is correct, please contact Sinexcel engineer.