

## User Manual

# RHF-Active

Active Harmonic filter

**Nominal Current 3.5A, 15A, 35A, 55A, 100A, 150A**

**Nominal Voltage 220V – 480V (50Hz / 60Hz)**



Version 01/2026



Marine



Oil & Gas



Water  
Treatment



General  
Industry



Data Center

**Contents**

<b>1. Important Information .....</b>	<b>5</b>
1.1 About the manual.....	5
1.2 Terms and definitions.....	5
1.3 Type code .....	6
1.4 Name plate .....	6
1.5 Legal regulations.....	7
<b>2. Safety precautions.....</b>	<b>8</b>
2.1 What this chapter contains .....	8
2.2 Safety definitions and warning symbols.....	9
2.3 General safety information .....	11
2.4 Safety responsible persons.....	12
2.5 Specification of wires and cables.....	13
2.6 Rest danger .....	13
<b>3. Fast start .....</b>	<b>14</b>
3.1 What this chapter contains .....	14
3.2 First check when unpacking .....	14
3.3 Suitability for the application .....	14
3.4 Environment conditions .....	14
3.5 Check of the installation.....	15
3.6 Simplified commissioning.....	15
<b>4. Product-Overview .....</b>	<b>16</b>
4.1 What this chapter contains .....	16
4.2 Function principle:.....	16
4.2.1 RHF-Active .....	17
4.2.2 RHF-Hybrid .....	17
4.3 Product characteristics.....	18
A) 3.5A.....	18
B) 15A.....	19
C) 35A.....	20
D) 55A.....	21
E) 100A.....	23
F) 150A.....	24

<b>5. Installation instructions.....</b>	<b>25</b>
5.1 What this chapter contains .....	25
5.2 Mechanical drawings.....	26
A. 3.5A .....	26
B. 15A .....	27
C. 35A + 55A.....	28
D. 100A + 150A.....	29
5.2.1 Mechanical installation .....	30
5.3 Electrical wiring: .....	31
5.3.1 Open Loop - 3P3W wiring.....	31
5.3.2 Open Loop - 3P4W wiring.....	32
5.3.3 Close Loop - 3P3W wiring.....	33
5.3.4 Close Loop - 3P4W wiring.....	34
5.3.3 LED status display .....	36
5.3.4 RS-485 and CAN Communication .....	37
5.3.5 Current transformer wiring .....	38
5.3.6 RHF-Active in parallel wiring .....	39
5.3.7 Selection of current transformers.....	40
5.3.8 Modification of wiring when using current transformers with high ratio .....	40
5.3.9 EPO and RHF-Active ID .....	41
5.3.10 Input and output interface.....	43
<b>6. Supervision- and control software.....</b>	<b>44</b>
6.1 What this chapter contains .....	44
6.2 Introduction in the system .....	44
6.2.1 Log In .....	44
<b>7. Maintenance and check of hardware.....</b>	<b>45</b>
7.1 What this chapter contains .....	45
7.2 Periodicity of maintenance .....	45
<b>8. Error description and repair .....</b>	<b>46</b>
8.1 What this chapter contains .....	46
8.2 Typical errors and repairs.....	46
<b>9 Appendix A.....</b>	<b>47</b>
9.1 Storage Conditions .....	47

## Contents

---

<b>10 Revcon Product Overview .....</b>	<b>47</b>
10.1 Revcon Product.....	47
10.2 Revcon Contact.....	48

## **1. Important Information**

### **1.1 About the manual**

These present operating instructions are the translation of the original instructions, which were composed in the official EU language German.

These operating instructions shall ensure safe operation of and with the filter module REVCON RHF-active. They contain security advices which must be observed and information which is necessary for an undisturbed operation of the units and for the exploitation of all advantages of the system.

All persons who work on and with the filter module REVCON RHF-Active must have accessible the operating instructions, or the equal chapters of the operating instructions for other with this option equipped REVCON products available. All persons must follow the relevant notes and designations.

The operating instructions must be complete and perfectly legible. Please read this manual carefully and follow all safety precautions before moving, installing, operating and servicing the RHF-Active Filter, if ignored, physical injury or death may occur, or damage may occur to the devices.

### **1.2 Terms and definitions**

#### **Filter module**

For „Filter module REVCON RHF-Active“ the term „Filter module“ will be used.

#### **Drive controller**

For the frequency inverter which is used together with the power feedback unit in the following the term „Controller“ is used

#### **Drive system**

For a drive system with harmonic filter, power feedback units, controller and other components of the drive system in the following the term „Drive system“ is used.

## User Manual RHF-Active

### 1.3 Type code

The type code is part of the name plate and contains important information about the active harmonic filter.

## RHF –Active 100 – 480 – 50/60 – 20 – A

Code	Nr.	detaillied designation	Detailed signification
Short form	①	Product designation	RHF: Revcon Harmonic Filter
Product type	②	Product type	Active: Active Harmonic Filter
Nominal current	③	Nominal current	100: 100 Ampere
Voltage class	④	Voltage class	480: 220-480V
Mains frequency	⑤	Mains frequency	50/60: 50Hz and 60Hz
IP	⑥	IP degree of protection	20: IP20
Version	⑦	A or B	-

### 1.4 Name plate



Serien-Nr. / Serial no.  
 Artikel-Nr. / Article no.  
 Typ / Type  
 Spannung / Voltage (UL)  
 Spannung / Voltage (CE)  
 Sicherheit / Safety Standard

I RMS / MAX  
 Gewicht / Weight  
 Umgebungstemp. / Ambient Temp.  
 Schutzart / Protection

ELTROPLAN-REVCON GmbH

#### Active Harmonic Filter

**234301634**

35000005  
 RHF-Active 55-480-50/60-20-A  
 380-480VAC, 3P, 50/60Hz  
 380-440VAC, 3P(+N), 50/60Hz  
 (UL) Conforms to UL Std.  
 508, 61800-5-1

55A / 55A  
 17 kg  
 Max 40°C  
 Type 1 / IP 20



## User Manual RHF-Active

### 1.5 Legal regulations

Marking	Name plate	CE-marking	Manufacturer/Seller
	Filter modules REVCON® RHF-Active are clearly marked by the content of the nameplate	Conformable to EC directive “low-voltage“	ELTROPLAN-REVCON Edisonstraße 3 59199 Bönen Germany
<b>Intended use</b>	<p><b>Filter module REVCON® RHF-Active</b></p> <ul style="list-style-type: none"> <li>• <b>only to use under the terms of this operating instructions and the required operational conditions</b></li> <li>• are components <ul style="list-style-type: none"> <li>– to reduce the harmonic distortions of the electrical network by specific B6 rectifiers and inverters</li> <li>– to fit in a machine</li> <li>– to assembly with other components to a machine together</li> </ul> </li> <li>• are electric equipment to assembly in a electrical enclosure or similar</li> <li>• locked up operations rooms</li> <li>• conform to the <b>protection requirements</b> of the EC directive “low-voltage “</li> <li>• are no machines in terms of the EC directive “machines“</li> <li>• are no <b>household appliances</b>, but components which are determined only for the further application in commercial use</li> </ul> <p><b>Drive system with filter module REVCON® RHF-Active</b></p> <ul style="list-style-type: none"> <li>• <b>conform to the EC directive “Electromagnetic Compatibility“, if they are installed by the specifications of the CE-typical drive control system</b></li> <li>• are applicable <ul style="list-style-type: none"> <li>– in the public electrical network and closed electrical networks.</li> <li>– in the industrial sector and in living areas as well as in business units.</li> </ul> </li> </ul> <p>The <b>responsibility</b> for the compliancy of the EC directive with the machine application is one for the user.</p>		
<i>Liability</i>	<ul style="list-style-type: none"> <li>• <b>The indicated information, technical data and notes in this operating instruction were updated at the time of the printing. No demands for changing a delivered filter module can be asserted by the information, figures and descriptions of these operating instructions.</b></li> <li>• The represented process engineering notes in this operating instructions and circuit details are <b>suggestions</b>, which <b>transferability</b> on the respective application must be verified. For the suitability of the specified procedures and circuit suggestions accepts the ELTROPLAN-REVCON GmbH no guarantee.</li> <li>• The data in these operating instructions describe the characteristic of the products without ensuring them.</li> <li>• No Liability will be taken over for damages and malfunctions which result by: <ul style="list-style-type: none"> <li>– disregard of the operating instructions</li> <li>– arbitrary changes on the filter module</li> <li>– operating errors</li> <li>– improper works on and with the inverter</li> </ul> </li> </ul>		
<i>Warranty</i>	<ul style="list-style-type: none"> <li>• <b>Warranty conditions: Refer to the sales - and delivery conditions of the ELTROPLAN-REVCON GmbH.</b></li> <li>• Immediately announce guarantee claims after the discovery of defects or faults</li> <li>• The warranty expires in all cases, in which even no liability claims can be <b>asserted</b>.</li> </ul>		
<i>Disposal</i>	<b>Material</b>	<b>Recycling</b>	<b>Disposal</b>
	Metal	●	-
	Plastic	●	-

---

	PCB		•
--	-----	--	---

## 2. Safety precautions

### 2.1 What this chapter contains

Please read this manual carefully and follow all safety precautions before moving, installing, operating and servicing the RHF-Active Filter, if ignored, physical injury or death may occur, or damage may occur to the devices.

If any physical injury, death, or damage to the devices occurs for ignoring to the safety precautions in the manual, our company will not be responsible for any damages and we are not legally bound in any manner.

## User Manual RHF-Active

### 2.2 Safety definitions and warning symbols







All Safety definitions have a uniform layout:

- The pictogram shows the kind of danger
- The signal word characterizes the severeness of danger
- The note describes the danger and suggest how to avoid the danger.



#### Signal Word **Mot de signal**

Note                      Noter

	Used Pictogram		Instruction	
<b>Warning of personal injury</b> <b>Avertissement de blessure corporelle</b>		Imminent danger by electricity <i>Danger imminent par l'électricité</i>	<b>Danger!</b> <b>Danger!</b>	Warns of an immediate imminent danger. In case of disrespect, death or severe injury may happen. <i>Avertit d'un danger imminent immédiat. En cas de manque de respect, la mort ou des blessures graves peuvent survenir.</i>
		Warning of an imminent danger <i>Avertissement d'un danger imminent</i>	<b>Warning</b> <b>Avertissement</b>	Warns of a possible, very dangerous situation. In case of disrespect, death or severe injury may happen. <i>Avertit d'une situation possible et très dangereuse. En cas de manque de respect, la mort ou des blessures graves peuvent survenir.</i>
		Dangerous Situation <i>Situation dangereuse</i>	<b>Caution!</b> <b>Mise en garde!</b>	Warns of a possible, dangerous situation. In case of disrespect, minor injury may happen. <i>Avertit d'une situation possible et dangereuse. En cas de manque de respect, des blessures mineures peuvent survenir.</i>
		Warning of hot surface <i>Avertissement de surface chaude</i>	<b>Warning!</b> <b>Avertissement</b>	Warns of touching of a hot surface. In case of disrespect, burnings may happen <i>Avertit de toucher une surface chaude. En cas de manque de respect, des brûlures peuvent survenir</i>
<b>Warning of property damages</b> <b>Avertissement de dommages matériels</b>		Harmful Situation <i>Situation préjudiciable</i>	<b>Stop!</b> <b>Arrêter</b>	Warns of possible property damage. In case of disrespect, the system and it's environment may be damaged <i>Met en garde contre d'éventuels dommages matériels. En cas de non-respect, le système et son environnement peuvent être endommagés</i>
<b>Useful information and hints for using</b> <b>Informations utiles et conseils d'utilisation</b>		Information <i>Information</i>	<b>Note!</b> <b>Noter!</b>	Marks a general, useful hint. If it is observed, usage of the system will be easier <i>Marque une indication générale et utile. S'il est observé, l'utilisation du système sera plus facile</i>



## Safety and application notes for drive systems

(following Low Voltage Directive 2006/95/EC)

### 1. General

During operation, filter modules may have, according to their type of protection, live, bare, in some cases also movable or rotating parts as well as hot surfaces.

Non-authorized removal of required cover, inappropriate use, incorrect installation or operation, creates the risk of severe injury to persons or damage to material assets.

Further information can be obtained from the documentation.

All operations concerning transport, installation and commissioning as well as maintenance must be carried out by qualified, skilled personnel (IEC 364 and CENELEC HD 384 or DIN VDE 0100 and IEC-Report 664 or DIN VDE 0110 and national regulations for the preventions of accidents must be observed).

According to this basic safety information qualified skilled personnel are persons who are familiar with the erection, assembly, commissioning and operation of the product and who have the qualifications necessary for their occupation .

### 2. Application as directed

Filter modules are components which are designed for installation in electrical systems or machinery.

When installing in machines, commissioning of the filter module (i.e. the starting of operation as directed) is prohibited until it is proven, that the machine corresponds to the regulations of the EC Directive (2006/42/EC) (Machinery Directive); EN 60204 must be observed.

Commissioning (i.e. starting operation as directed) is only allowed when there is compliance with the EMC-Directive (2004/108/EC).

The filter modules meet the requirements of the Low-Voltage Directive (2006/95/EEC). The harmonized standards of the prEN 50178/DIN VDE 0160 series together with EN 60439-1/DIN VDE 0660 part 500 and EN 60146/DIN VDE 0558 are applicable for the power feedback unit. The technical data and information on the connection conditions must be obtained from the nameplate and the documentation and must be observed in all cases.

### 3. Transport, storage

Notes on transport, storage and appropriate handling must be observed. At non-observance any warranty expires. The filter module unit has to be protected from inadmissible stress. The transport is only valid in original packaging and in the thereon by pictograms marked transport position. In particular during transport and handling no components are allowed to be bent and / or isolating distances may not be altered. The modules are equipped with electrostatic sensitive devices, which may be damaged by improper handling. Therefore, it has to be avoided to get in contact with electronic components. If electronic components are damaged mechanically the module must not be put into operation, as it cannot be ensured, that all relevant standards apply. **This safety information must be kept!**

### 4. Erection

The modules must be erected and cooled according to the regulations of the corresponding documentation.

The filter modules must be protected from inappropriate loads. Particularly during transport and handling, components must not be bent and / or isolating distances must not be changed. Touching of electronic components and contacts must be avoided.

Filter modules contain electro-statically sensitive components which can easily be damaged by inappropriate handling. Electrical components must not be damaged or destroyed mechanically (health risk are possible!).

### 5. Electrical Connection

When working on live filter modules, the valid national regulations for the prevention of accidents (e.g. VBG 4) must be observed. Before any installation or connection works, the plant has to be switched off and to be secured properly.

The electrical installation must be carried out according to the appropriate regulations (e.g. cable cross-sections, fuses, PE-connection). More detailed information is included in the documentation. When using the filter module with controllers without safe separation from the supply line (to VDE 0100) all control wiring has to be include in further protective measures (e.g. double insulated or shielded, grounded and insulated) . Notes concerning the installation in compliance with EMC – such as screening, grounding, arrangement of filters and laying of cables – are included in the chapter installation of this documentation. These notes must be also observed in all cases for filter modules with the CE-mark. The compliance with the required limit values demanded by the EMC legislation is the responsibility of the manufacturer of the system or machine.

### 6. Operation

Systems where filter modules are installed, if applicable, have to be equipped with additional monitoring and protective devices according to the valid safety regulations e.g. law on technical tools, regulations for the prevention of accidents, etc.. After disconnecting the filter module the supply voltage, live parts of the filter module and power connections must not be touched immediately, because of possibly charged capacitors. For this, observe the corresponding labels on the drive controllers.

During operation, all covers and doors must be closed

### 7. Maintenance and service

The manufacturer's documentation must be observed.

**The product-specific safety and application notes in these Operating Instructions must also be observed!!**

### 2.3 General safety information

- These safety regulations are not entitled to completeness. In case of questions please contact our technicians.
- When commissioning the filter module is compliant with the state of the art. The filter module generally allows safe operation.
- The statements of this manual describe the attributes of the products without guaranteeing them.
- The filter module unit may expose persons, the power feedback units itself and other material to danger, if
  - non-qualified personal works at and with the filter module
  - the filter module is used in opposite to its purpose.
- Filter modules have to be projected in a way, that they fulfil their function and don't expose persons to danger, if they are mounted correctly and are used in accordance with their purpose. This applies also for the interplay with the whole plant.
- The units, operational data and circuit details described in this manual have to be understood analogously and have to be checked for transferability to each application.
- Use the drive system only in flawless condition.
- Modifications of the filter modules without consultation of a REVCON<sup>®</sup>-technician are not allowed generally .
- The warranty given by us expires, if the unit is modified or (even partially) dismantled or if it is used in contradiction to our instructions.
- The constructor of the plant, who has to know the technical guidelines, bears the responsibility for the correct selection and arrangement of the electrical components.
- Putting into operation of the power feedback unit is only admissible at VDE-compliant network of electrical power supply. Non observance may damage the device!
- In accordance with the corresponding standards and guidelines the operation on even for a short time over-compensated networks ( $\cos\varphi \leq 1$ , capacitive) respectively on un-choked compensation-units is not admissible. If this is done nevertheless, overvoltage will occur (caused by oscillating currents), which may damage all connected components, especially electronic units like controllers and filter modules.
- It is recommended that the RHF modules are installed on a network where the SCR (Short Circuit Ratio) meets the requirements of Table 2 in IEEE Std 519-2022.

**Stop!**

Undisturbed and safe operation of the filter module is possible only if the hints of this instruction are observed.

---

**If they are not observed, in some cases malfunctions and damages may occur:**

- Observe specified mains voltage.
- Power and control cables must be installed with distance (> 15cm)
- Use screened / twisted control wires. Connect screen to PE at both ends!
- Ensure good grounding of drive, motor and filter module. Connect the screen of power cables to ground extensive at both ends. (remove lacquer)!
- Observe star layout for grounding of cabinets and systems (AVOID ground loops!)
- The filter module is designed for fixed mounting and electrical connection.
- The ground wire must have a minimum cross section of 2,5mm<sup>2</sup> (depending on filter module size).

**2.4 Safety responsible persons****Operator**

- The operator is any natural or legal person who is using the system or let someone use the system.
- The operator and / or the safety responsible person must take care for:
  - all relevant rules, guidelines and laws must be observed
  - only qualified personnel will work with and on the system
  - the manual will be available for the personnel during working at the system.
  - unqualified personnel will be forbidden to work on the system.

**Qualified personal**

---

**Stop!**

- Qualified technical personnel are persons, who
    - have appropriate training, knowledge and experience
    - are informed about relevant specifications, standards and accident prevention regulations
    - are trained in the installation and operation of relevant systems
    - are able to recognize and avoid possible dangers(Definition for qualified personnel in accordance to IEC 364)
-

## 2.5 Specification of wires and cables

- The used wires and cables must comply the relevant standards at place of installation and operation.
- Rules regarding minimum PE cross section must be observed in any case!

## 2.6 Rest danger

---

### **Danger!**



### **ELECTRIC SHOCK OR ARC FLASH**

After switching off, internal parts may stay live for up to fifteen minutes!

Before touching, verify that no voltage is present.

Failure to comply will result in death or serious injury.

---

### **Danger!**



### **Electric shock or Arc Flash**

Pour L'entretien, debranchez toute l'alimentation électrique.

- Attendez 15 minutes. – Vérifiez qu'il n'y a pas de tension

Le défaut de le faire peut entraîner la mort ou des blessures graves.

---

### 3. Fast start

#### 3.1 What this chapter contains

This chapter describes the basic guidelines for installation and commissioning of RHF-ACTIVE, which should be observed for fast and easy usage.

#### 3.2 First check when unpacking

Please check the goods during and immediately after receipt on the following characteristics:

1	Please check the packaging for intactness and dryness. If this is not the case, immediately get in contact with the sender.
2	Please check if the type-code on the packaging matches the ordered product. If this is not the case, immediately get in contact with the sender.
3	Please check for any kind of moisture inside the packaging and for any kind of damages at the product. If this is not the case, immediately get in contact with the sender.
4	Please check if the type code on the packaging matches the data on the name plate. If this is not the case, immediately get in contact with the sender.
5	Please check if the packaging contains all accessories including manual. If this is not the case, immediately get in contact with the sender.

#### 3.3 Suitability for the application

Please check if all current transformers and the adjusted parameters are suitable for the application before you start up the RHF-Active for the first time.

#### 3.4 Environment conditions

Please check and consider the following environment conditions before starting the installation:

1	Check for the ambient temperature to be below 40°C. If it is higher, consider the derating mentioned in Chapter 4.3 Product characteristics.
2	Check for the ambient temperature to be above -10°C. If it is lower, a heater must be installed. Hint: Ambient temperature means the temperature inside the cabinet with the RHF-Active.
3.	Check for the installation height to be below 2000m above sea level. If it is higher, consider derating of 1%/100m. This would mean that an RHF-Active 100A at 3000 A.S.M.L. must be loaded with not more than 90A. Operation above 4000m is not acceptable.
4	Check for ambient moisture to be below 90%. If the moisture is higher, measures for reduction of moisture must be taken.
5	Check for no direct sunlight exposition of the RHF-Active and for no dust impact. If that could happen, countermeasures must be taken.

### 3.5 Check of the installation

Perform this check AFTER installation but BEFORE first powering up:

1	Check the correct mounting and wiring of the current transformer (CT). The wires used must comply with the requirements of components (CT, RHF-Active) and with the place of installation.
3.	Check that power and controls wires are installed separately and that EMC guidelines are observed.
4	Check the grounding of the system and components for compliance with guidelines and requirements of the drives.
5	Check if the clearance between the components complies with the requirements of these instructions.
6	Check if the installation meets the requirements of these instructions. The RHF-Active must be mounted in an upright position.
7	Check if the EPO connector is equipped with a short circuit wire. This is mandatory to ensure that the RHF-Active will NOT start at first powering up.

### 3.6 Simplified commissioning

The REVCAN RHF-ACTIVE is a largely automated product for reduction of harmonics.

Complete the simplified commissioning as described below BEFORE first usage:

1	Check all parameters of the monitoring system on your computer.
2	Check the correct wiring of the current transformers
3	If several products are used in parallel, check for compliant adjustment of the parameters.
4	<b>If the RHF-Active has not been powered up for &gt;4 months, wait 1 hour before starting it (RUN). This action ensures a prolonged lifetime of the capacitors.</b>

Hint: If the result of harmonic compensation is not satisfying, please check the parameters once again firstly, wiring (especially polarity) of the current transformers secondly. If everything is o.k. modify the phase angle of the system to achieve even better results.

For extensive commissioning and software navigation, please refer to the Commissioning Guide.

For the detailed storage conditions please see Appendix A on Chapter 9.



#### Stop!

If RHF-Active is started (RUN) not observing step 4, the product's lifetime will be affected.

---



#### Hint!

This manual contains hints on current transformers in several chapters. As during installing the current transformers, one can cause a lot of issues, all hints are summarised in chapter 5.

---

## 4. Product-Overview

### 4.1 What this chapter contains

This chapter describes the function principle, the characteristics of the product and dimensions.

### 4.2 Function principle:

The following drawings show the principle, simplified setup of active harmonic filters.

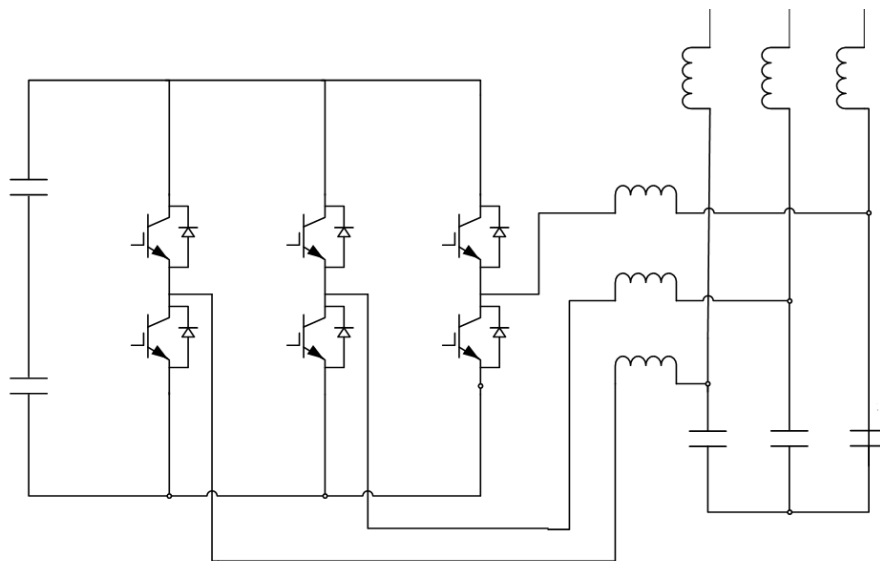

Simplified topology of RHF-Active 15-150A

### 4.2.1 RHF-Active

Non-linear Loads (e.g. frequency converter) load the mains with distorted (non-sinewave) currents. Such currents increase losses in wires and transformers and cause distorted voltage, which stress all connected loads in multiple manners (e.g. resulting in reduced lifetime). RHF-Active measure the distorted currents and generate for each harmonic up to 61<sup>st</sup> a phase shifted compensation current. The sum of distorted load current and compensation current results in a (nearly) sinewave grid current. The required nominal current of the RHF-Active depends on the nominal current of the load and its distortion. If the distorting load is a frequency converter, the percentage of compensation current is ca. 25-30%. This results in a grid current with mitigated distortion of ca. 5%.

### 4.2.2 RHF-Hybrid

Especially for high loads (>>100kW) quite high level of compensation current is required. To keep this level low, the RHF-Hybrid-System may be used. This system consists out of RHF-Active added by one or two RHF-Passive. The RHF-Active controls the usage of passive filter circuits, resulting in several important advantages:

- Only ca. 10% of the nominal current are left for active compensation.
- The resulting distortion of the grid current may go down to less than 1% (THDi <1%).
- The total costs are significantly lower than by using exclusively active filters.

**4.3 Product characteristics**
**A) 3.5A**

General Data	
Mains voltage	220-480V (+10% / -10%)
Network type	3-phase with/ without neutral 3P4W/3P3W 3P3W (220-480V) 3P4W (220-415V)
Nominal current	3.5 A
Line current	15A (Internal CTs)
Colour	white
Electrical data	
Mains frequency	50Hz / 60Hz ( $\pm 2$ Hz)
Harmonic compensation	2nd – 61st Harmonic
Reaction time	20 $\mu$ s
Response time	Load level (20%, 50%, 90%): 5ms, 10ms, 20ms
Switching frequency	55kHz-75kHz, typical 65kHz
Technology	Advanced SIC
System topology	Two Level Topology
Function	Harmonic compensation Power factor correction Three phase balancing
Main Supply Terminals & PE	Feed-through, 0.2-4mm <sup>2</sup> (10-24AWG) Tightening torque: 1.5Nm
User-Interface & Remote monitoring	
HMI	Not present / external
Communication protocol	RS485
PC-Software	V3.2.21
Efficiency	
$\eta$	99%
Power loss (100% load)	95W
Installation / Configuration	
Current transformer ratio	Internal CTs 15A
Cooling	Internal fans
Air flow requirement	>105m <sup>3</sup> /h
Mounting	Wall mount
Parallel configuration	3
Extensions	Modules in parallel
Protection level	IP20
Cable entering	bottom
RFI level	class A
Environmental	
Ambient temperature	-10°C~40°C
Temperature-Derating	°C / Max ambient temperature with derating  60°C $\geq$ Td' >55°C, (Capacity) : 30%; 55°C $\geq$ Td' >50°C, (Capacity) : 50%; 50°C $\geq$ Td' >45°C, (Capacity) : 70%; 45°C $\geq$ Td' >40°C, (Capacity) : 100%; 40°C $\geq$ Td', (Capacity) : 100%;
Maximum temperature	60°C

Relative Humidity	5%~95% Class F without condensation
Altitude	below 2000m
Altitude Derating	above 2000m (10%/1000m to 4000m)
<b>Weight, Dimensions</b>	
Weight	2.6kg
Dimensions W*D*H[mm]	50*159*313
<b>Certifications</b>	
Certifications	CE
<b>Transport/Storage</b>	
Ambient temperature (Transport)	-10°C~+65°C (following DIN EN 50178)
Ambient temperature (Storage)	-10°C~+55°C (following DIN EN 50178)

**B) 15A**

General Data				
Mains voltage	220-480V (+10% / -10%)			
Network type	3-phase with/ without neutral 3P4W/3P3W 3P3W (220-480V) 3P4W (220-415V)			
Nominal current	15 A			
Colour	white			
Electrical data				
Mains frequency	50Hz / 60Hz ( $\pm 2$ Hz)			
Harmonic compensation	2nd – 61st Harmonic			
Reaction time	20 $\mu$ s			
Response time	Load level (20%, 50%, 90%): 5ms, 10ms, 20ms			
Switching frequency	40kHz-60kHz, typical 50kHz			
Technology	Advanced SIC			
System topology	Two Level Topology			
Function	Harmonic compensation Power factor correction Three phase balancing			
Main Supply Terminals	Feed-through, 0.5-25mm <sup>2</sup> (20-4AWG) Tightening torque, min-max.: 1.8-2.0Nm M5 (PE terminal)			
Internal CT impedance	Test Parameter	Phase-A	Phase-B	Phase-C
	Ls	0.55uH	0.65uH	0.57uH
	Rs	17.1m $\Omega$	18.34m $\Omega$	16.77m $\Omega$
User-Interface & Remote monitoring				
HMI	Not present / external			
Communication protocol	RS485			
PC-Software	V3.2.21			
Efficiency				
$\eta$	98%			
Power loss (100% load)	274W			
Installation / Configuration				
Noise	<60db			
Current transformer ratio	5/5~10000/5			
Cooling	Internal fans			
Air flow requirement	>105m <sup>3</sup> /h			
Mounting	Wall mount			

Parallel configuration	Unlimited
Extensions	Modules in parallel
Protection level	IP20
Cable entering	bottom
RFI level	class A
<b>Environmental</b>	
Ambient temperature	-10°C~40°C
Temperature-Derating	°C / Max ambient temperature with derating 60°C ≥ Td' > 55°C, (Capacity) : 30%; 55°C ≥ Td' > 50°C, (Capacity) : 50%; 50°C ≥ Td' > 45°C, (Capacity) : 70%; 45°C ≥ Td' > 40°C, (Capacity) : 100%; 40°C ≥ Td', (Capacity) : 100%;
Maximum temperature	60°C
Relative Humidity	5%~95% Class F without condensation
Altitude	below 2000m
Altitude Derating	above 2000m (10%/1000m to 4000m)
<b>Weight, Dimensions</b>	
Weight	9.2kg
Dimensions W*D*H[mm]	86*260*410
<b>Certifications</b>	
Certifications	CE, UL
<b>Transport/Storage</b>	
Ambient temperature (Transport)	-10°C~+65°C (following DIN EN 50178)
Ambient temperature (Storage)	-10°C~+55°C (following DIN EN 50178)

**C) 35A**

<b>General Data</b>	
Mains voltage	220-480V (+10% / -10%)
Network type	3-phase with/ without neutral 3P4W/3P3W 3P3W (220-480V) 3P4W (220-415V)
Nominal current	35 A
Colour	white
<b>Electrical data</b>	
Mains frequency	50Hz / 60Hz (±2Hz)
Harmonic compensation	2nd – 61st Harmonic
Reaction time	20 µs
Response time	Load level (20%, 50%, 90%): 5ms, 10ms, 20ms
Switching frequency	40kHz-60kHz, typical 50kHz
Technology	Advanced SIC
System topology	Two level topology
Function	Harmonic compensation Power factor correction Three phase balancing
Main Supply Terminals	Feed-through, 2.5-25mm <sup>2</sup> (20-2AWG) Tightening torque, min-max.: 2.5-3.0Nm M5 (PE terminal)

Internal CT impedance	Test Parameter	Phase-A	Phase-B	Phase-C
	Ls	0.6uH	0.61uH	0.62uH
	Rs	15.42mΩ	20.01mΩ	19.5mΩ
<b>User-Interface &amp; Remote monitoring</b>				
HMI	Not present / external			
Communication protocol	RS485			
PC-Software	V3.2.21			
<b>Efficiency</b>				
$\eta$	98.1%			
Power loss (100% load)	556W			
<b>Installation / Configuration</b>				
Noise	<60db			
Current transformer ratio	5/5~10000/5			
Cooling	Internal fans			
Air flow requirement	>160m <sup>3</sup> /h			
Mounting	Wall mount			
Parallel configuration	Unlimited			
Extensions	Modules in parallel			
Protection level	IP20			
Cable entering	bottom			
RFI level	class A			
<b>Environmental</b>				
Ambient temperature	-10°C~40°C			
Temperature-Derating	°C / Max ambient temperature with derating 60°C ≥Td' >55°C, (Capacity) : 40%; 55°C ≥Td' >50°C, (Capacity) : 60%; 50°C ≥Td' >45°C, (Capacity) : 80%; 45°C ≥Td' >40°C, (Capacity) : 100%; 40°C ≥Td', (Capacity) : 100%;			
Maximum temperature	60°C			
Relative Humidity	5%~95% Class F without condensation			
Altitude	below 2000m			
Altitude Derating	above 2000m (10%/1000m to 4000m)			
<b>Weight, Dimensions</b>				
Weight	15.8kg			
Dimensions W*D*H(mm)	105*360*560			
<b>Certifications</b>				
Certifications	CE, UL			
<b>Transport/Storage</b>				
Ambient temperature (Transport)	-10°C~+65°C (following DIN EN 50178)			
Ambient temperature (Storage)	-10°C~+55°C (following DIN EN 50178)			

#### D) 55A

<b>General Data</b>	
Mains voltage	220-480V (+10% / -10%)
Network type	3-phase with/ without neutral 3P4W/3P3W 3P3W (220-480V) 3P4W (220-415V)

Nominal current	55 A			
Colour	White			
<b>Electrical data</b>				
Mains frequency	50Hz / 60Hz ( $\pm 2$ Hz)			
Harmonic compensation	2nd – 61st Harmonic			
Reaction time	20 $\mu$ s			
Response time	Load level (20%, 50%, 90%): 5ms, 10ms, 20ms			
Switching frequency	40kHz-60kHz, typical 50kHz			
Technology	Advanced SIC			
System topology	Two level topology			
Function	Harmonic compensation Power factor correction Three phase balancing			
Main Supply Terminals	Feed-through, 2.5-25mm <sup>2</sup> (20-2AWG) Tightening torque, min-max.: 2.5-3.0Nm M5 (PE terminal)			
Internal CT impedance	Test Parameter	Phase-A	Phase-B	Phase-C
	Ls	0.6uH	0.61uH	0.62uH
	Rs	15.42m $\Omega$	20.01m $\Omega$	19.5m $\Omega$
<b>User-Interface &amp; Remote monitoring</b>				
HMI	Not present / external			
Communication protocol	RS485			
PC-Software	V3.2.21			
<b>Efficiency</b>				
$\eta$	>98.2%			
Power loss (100% load)	833W			
<b>Installation / Configuration</b>				
Noise	<60db			
Current transformer ratio	5/5~10000/5			
Cooling	Internal fans			
Air flow requirement	>160m <sup>3</sup> /h			
Mounting	Wall mount			
Parallel configuration	Unlimited			
Extensions	Modules in parallel			
Protection level	IP20			
Cable entering	bottom			
RFI level	class A			
<b>Environmental</b>				
Ambient temperature	-10 $^{\circ}$ C~40 $^{\circ}$ C			
Temperature-Derating	$^{\circ}$ C / Max ambient temperature with derating 60 $^{\circ}$ C $\geq$ Td' >55 $^{\circ}$ C, (Capacity) : shut down; 55 $^{\circ}$ C $\geq$ Td' >50 $^{\circ}$ C, (Capacity) : 50%; 50 $^{\circ}$ C $\geq$ Td' >45 $^{\circ}$ C, (Capacity) : 70%; 45 $^{\circ}$ C $\geq$ Td' >40 $^{\circ}$ C, (Capacity) : 90%; 40 $^{\circ}$ C $\geq$ Td', (Capacity) : 100%;			
Maximum temperature	55 $^{\circ}$ C			
Relative Humidity	5%~95% Class F without condensation			
Altitude	below 2000m			
Altitude Derating	above 2000m (10%/1000m to 4000m)			
<b>Weight, Dimensions</b>				

Weight	18kg
Dimensions W*D*H(mm)	105*360*560
<b>Certifications</b>	
Certifications	CE, UL
<b>Transport/Storage</b>	
Ambient temperature (Transport)	-10°C~+65°C (following DIN EN 50178)
Ambient temperature (Storage)	-10°C~+55°C (following DIN EN 50178)

**E) 100A**

General Data				
Mains voltage	220-480V (+10% / -10%)			
Network type	3-phase with/ without neutral 3P4W/3P3W 3P3W (220-480V) 3P4W (220-415V)			
Nominal current	100 A			
Colour	White			
Electrical data				
Mains frequency	50Hz / 60Hz (±2Hz)			
Harmonic compensation	2nd – 61st Harmonic			
Reaction time	20 µs			
Response time	Load level (20%, 50%, 90%): 5ms, 10ms, 20ms			
Switching frequency	30kHz-50kHz, typical 40kHz			
Technology	Advanced SIC			
System topology	Two level topology			
Function	Harmonic compensation Power factor correction Three phase balancing			
Main Supply Terminals	Barrier terminal, screw connection M8, 10-70mm <sup>2</sup> (8-3/0AWG) Tightening torque, min-max.: 3.5-8.0Nm M8 (PE terminal)			
Internal CT impedance	Test Parameter	Phase-A	Phase-B	Phase-C
	Ls	0.86uH	0.62uH	0.87uH
	Rs	11.53mΩ	15.87mΩ	8.3mΩ
User-Interface & Remote monitoring				
HMI	Not present / external			
Communication protocol	RS485			
PC-Software	V3.2.21			
Efficiency				
η	98.5%			
Power loss (100% load)	1283W			
Installation / Configuration				
Noise	<60db			
Current transformer ratio	5/5~10000/5			
Cooling	Internal fans			
Air flow requirement	>160m <sup>3</sup> /h			
Mounting	Wall mount			
Parallel configuration	Unlimited			
Extensions	Modules in parallel			
Protection level	IP20			

Cable entering RFI level	bottom class A
<b>Environmental</b>	
Ambient temperature	-10°C~40°C
Temperature-Derating	°C / Max ambient temperature with derating 60°C ≥ Td' > 55°C, (Capacity) : 80%; 55°C ≥ Td' > 50°C, (Capacity) : 90%; 50°C ≥ Td' > 45°C, (Capacity) : 95%; 45°C ≥ Td' > 40°C, (Capacity) : 100%; 40°C ≥ Td', (Capacity) : 100%;
Maximum temperature	60°C
Relative Humidity	5%~95% Class F without condensation
Altitude	below 2000m
Altitude Derating	above 2000m (10%/1000m to 4000m)
<b>Weight, Dimensions</b>	
Weight	31kg
Dimensions W*D*H(mm)	97*482.5*722
<b>Certifications</b>	
Certifications	CE, UL
<b>Transport/Storage</b>	
Ambient temperature (Transport)	-10°C~+65°C (following DIN EN 50178)
Ambient temperature (Storage)	-10°C~+55°C (following DIN EN 50178)

**F) 150A**

<b>General Data</b>				
Mains voltage	220-480V (+10% / -10%)			
Network type	3-phase with/ without neutral 3P4W/3P3W 3P3W (220-480V) 3P4W (220-415V)			
Nominal current	150 A			
Colour	White			
<b>Electrical data</b>				
Mains frequency	50Hz / 60Hz (±2Hz)			
Harmonic compensation	2nd – 61st Harmonic			
Reaction time	20 μs			
Response time	Load level (20%, 50%, 90%): 5ms, 10ms, 20ms			
Switching frequency	30kHz-50kHz, typical 40kHz			
Technology	Advanced SIC			
System topology	Two level topology			
Function	Harmonic compensation Power factor correction Three phase balancing			
Main Supply Terminals	Barrier terminal, screw connection M8, 10-70mm <sup>2</sup> (8-3/0AWG) Tightening torque, min-max.: 3.5-8.0Nm M8 (PE terminal)			
Internal CT impedance	Test Parameter	Phase-A	Phase-B	Phase-C
	Ls	0.86uH	0.62uH	0.87uH

	Rs	11.53mΩ	15.87mΩ	8.3mΩ
<b>User-Interface &amp; Remote monitoring</b>				
HMI	Not present / external			
Communication protocol	RS485			
PC-Software	V3.2.21			
<b>Efficiency</b>				
$\eta$	98.3%			
Power loss (100% load)	2120W			
<b>Installation / Configuration</b>				
Noise	<60db			
Current transformer ratio	5/5~10000/5			
Cooling	Internal fans			
Air flow requirement	>160m <sup>3</sup> /h			
Mounting	Wall mount			
Parallel configuration	Unlimited			
Extensions	Modules in parallel			
Protection level	IP20			
Cable entering	bottom			
RFI level	class A			
<b>Environmental</b>				
Ambient temperature	-10°C~40°C			
Temperature-Derating	°C / Max ambient temperature with derating 60°C ≥ Td' > 55°C, (Capacity) : shut down; 55°C ≥ Td' > 50°C, (Capacity) : 80%; 50°C ≥ Td' > 45°C, (Capacity) : 90%; 45°C ≥ Td' > 40°C, (Capacity) : 95%; 40°C ≥ Td', (Capacity) : 100%;			
Maximum temperature	55°C			
Relative Humidity	5%~95% Class F without condensation			
Altitude	below 2000m			
Altitude Derating	above 2000m (10%/2000m to 4000m)			
<b>Weight, Dimensions</b>				
Weight	33kg			
Dimensions W*D*H(mm)	97*482.5*722			
<b>Certifications</b>				
Certifications	CE, UL			
<b>Transport/Storage</b>				
Ambient temperature (Transport)	-10°C~+65°C (following DIN EN 50178)			
Ambient temperature (Storage)	-10°C~+55°C (following DIN EN 50178)			

## 5. Installation instructions

### 5.1 What this chapter contains

This chapter describes mechanical and electrical installation.

## 5.2 Mechanical drawings

### A. 3.5A

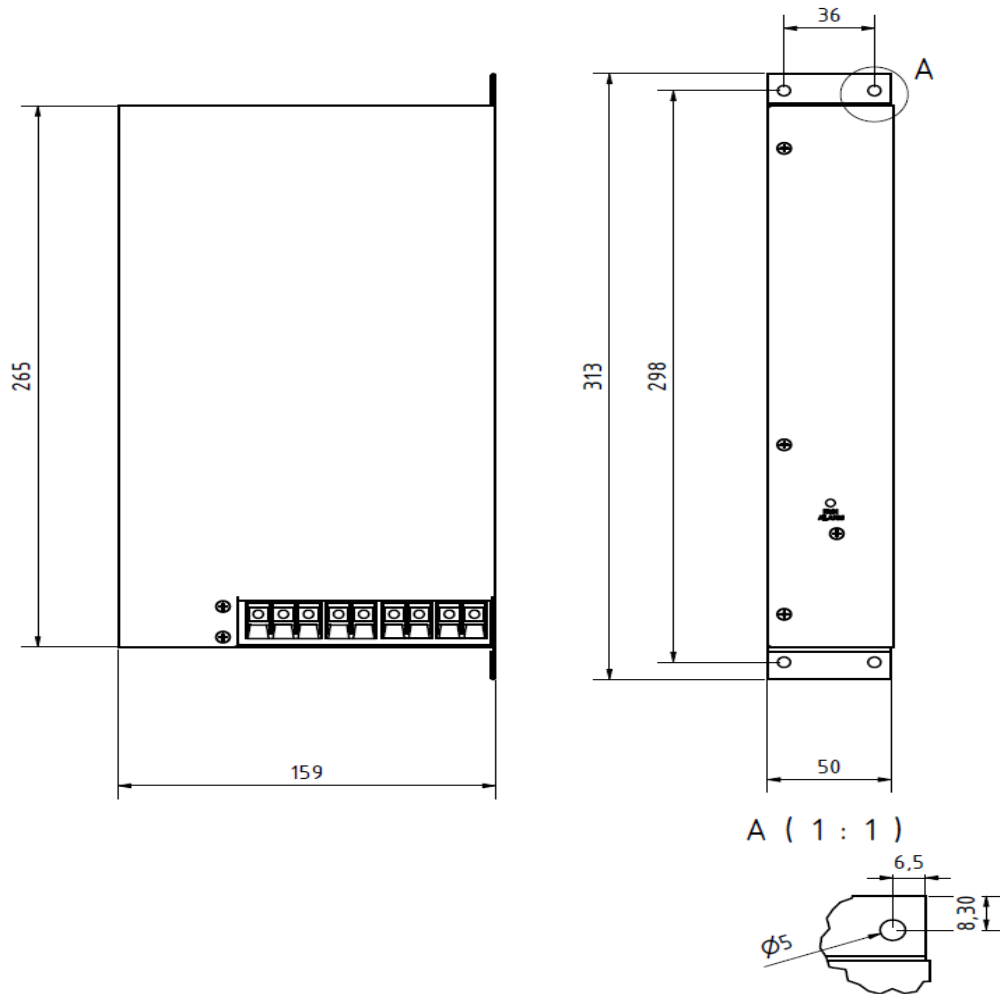

**B. 15A**

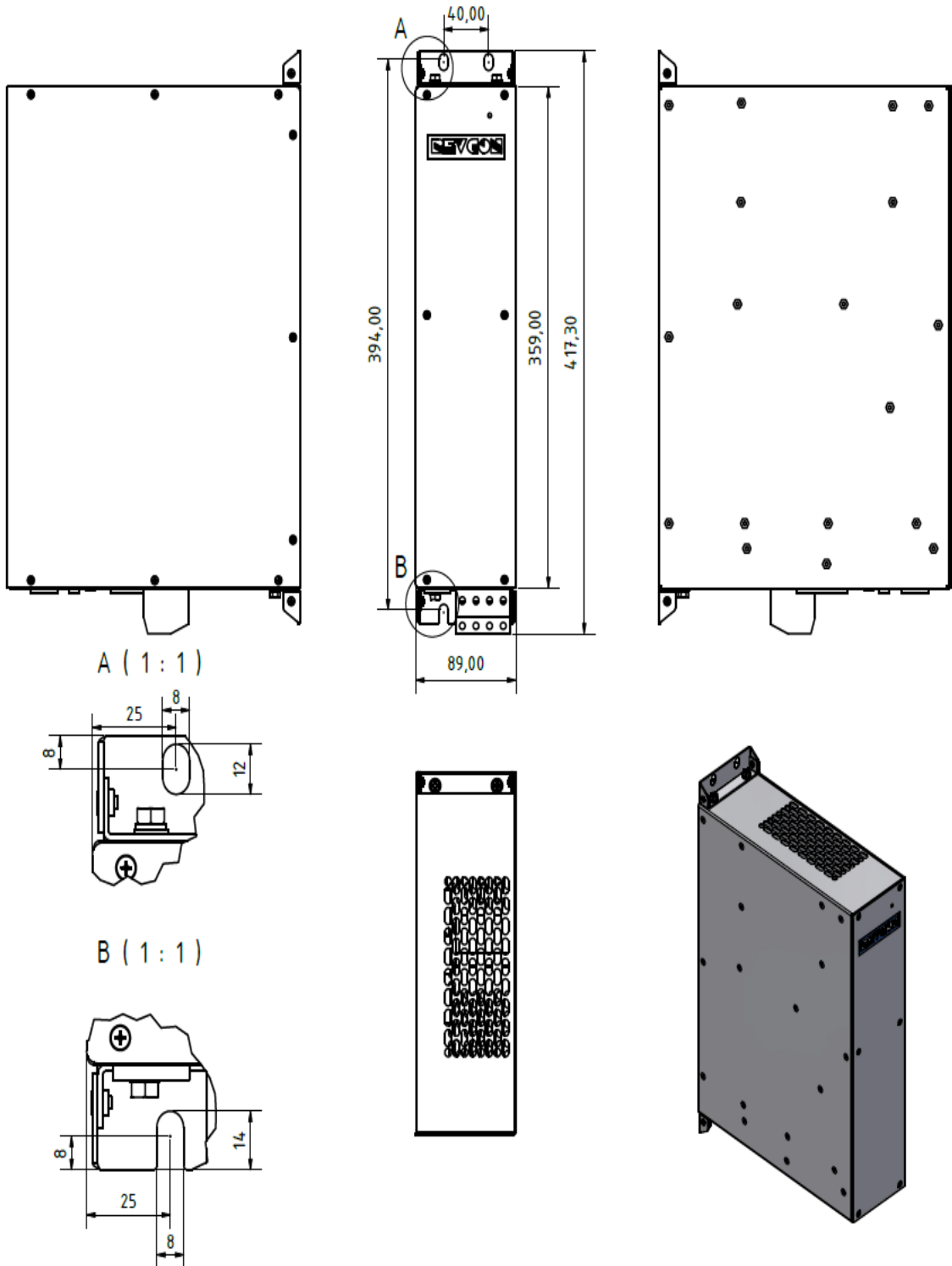

C. 35A + 55A

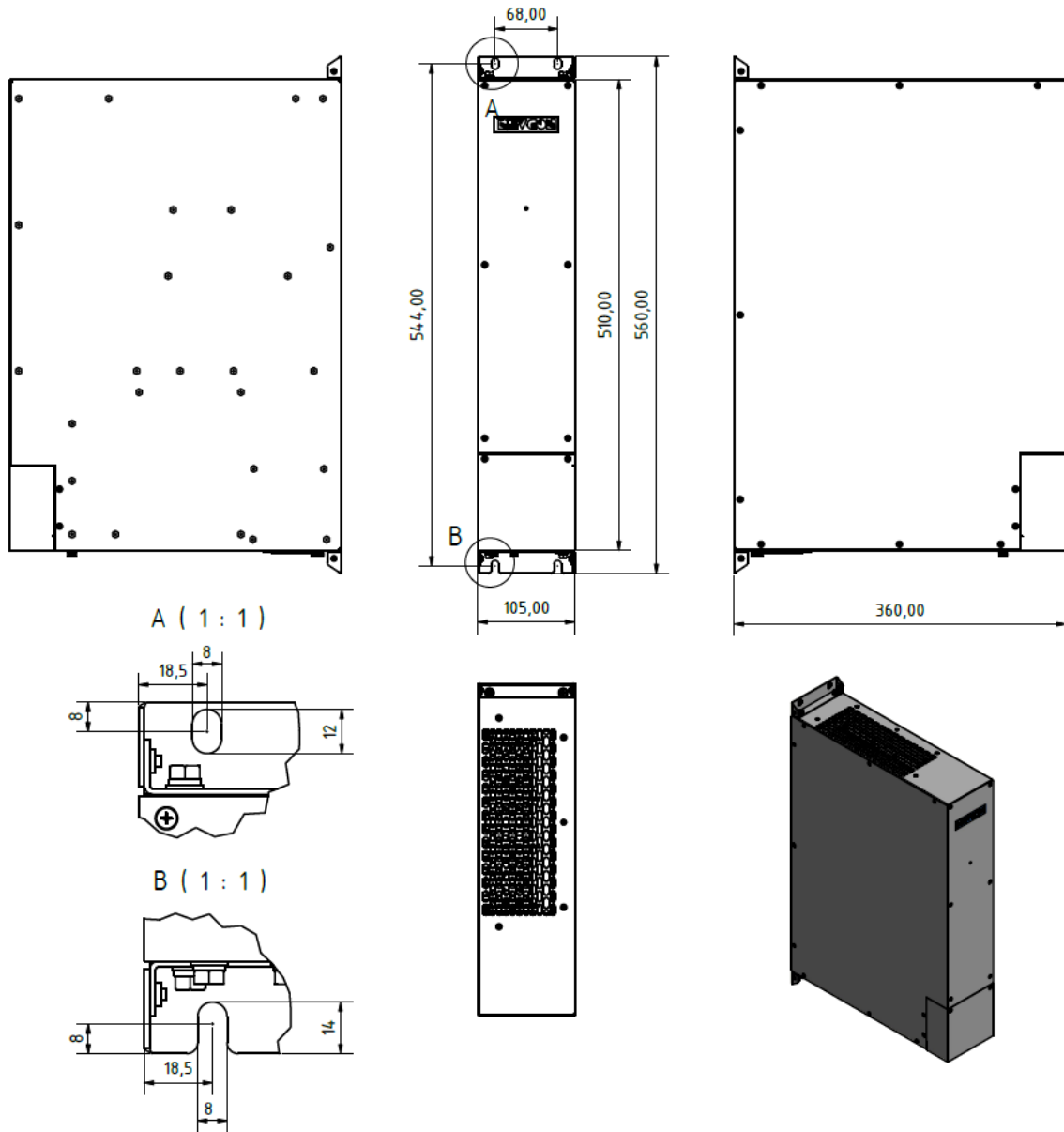

**D. 100A + 150A**

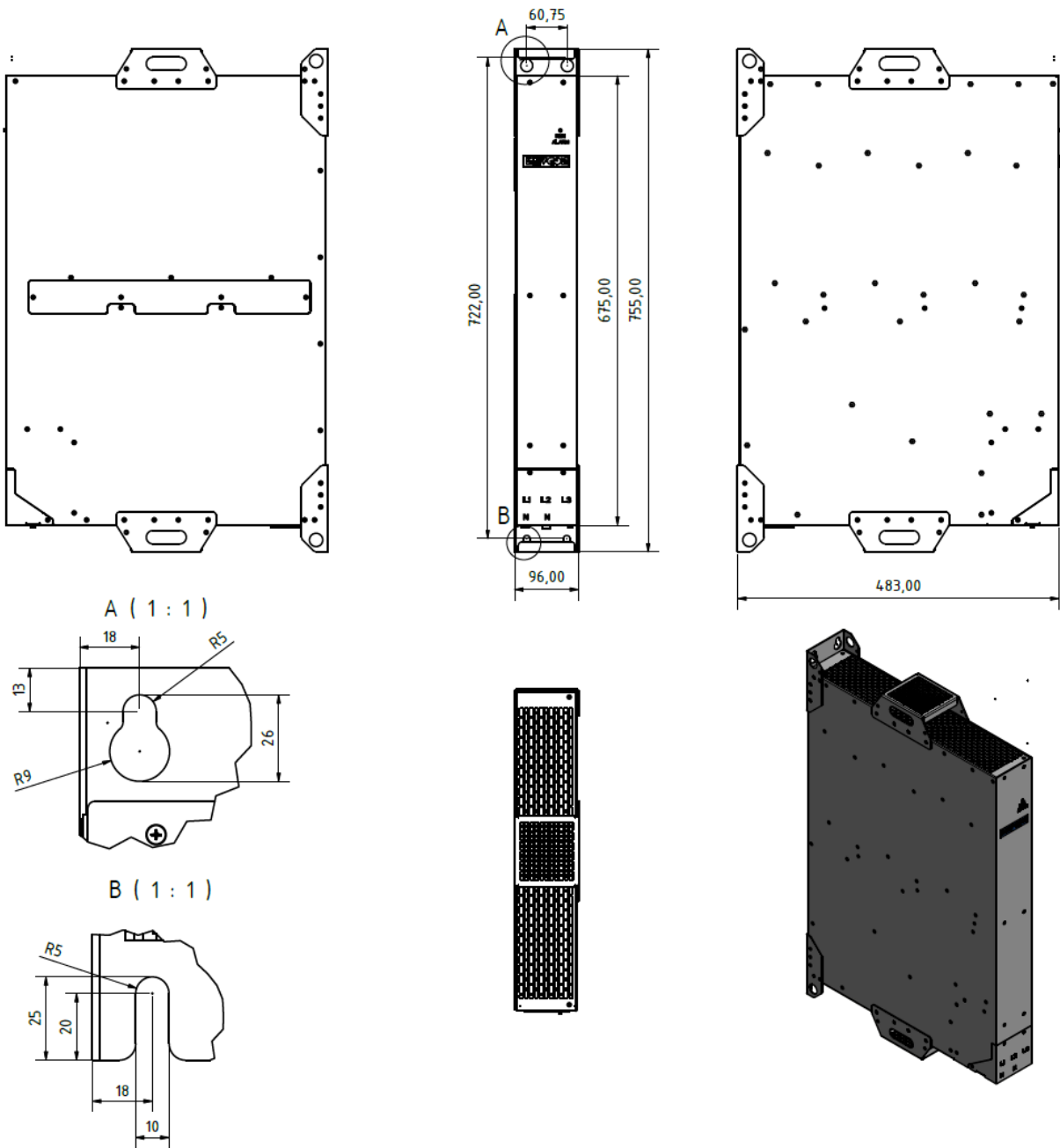

### 5.2.1 Mechanical installation

For safe and undisturbed operation, it is mandatory to follow these instructions for mechanical installation:

1. Clearance between RHF-Active and other components like chokes, cabinet walls, drives:  
≥100mm in horizontal (left/right) and ≥100mm in vertical direction (bottom)
2. Clearance between RHF-Active and other RHF-Active:  
≥10mm in horizontal (left/right) and ≥100mm in vertical direction (bottom)
3. Min. clearance in vertical direction (top):  
RHF-Active 15A : 130mm                      RHF-Active 35A : 180mm  
RHF-Active 55A : 180mm                    RHF-Active 100/150A : 230mm
4. Use screws with min. diameters  
RHF-Active 15A : 6mm                      RHF-Active 35A : 6mm  
RHF-Active 55A : 6mm                      RHF-Active 100/150A : 8mm

**5.3 Electrical wiring:**

**5.3.1 Open Loop - 3P3W wiring**

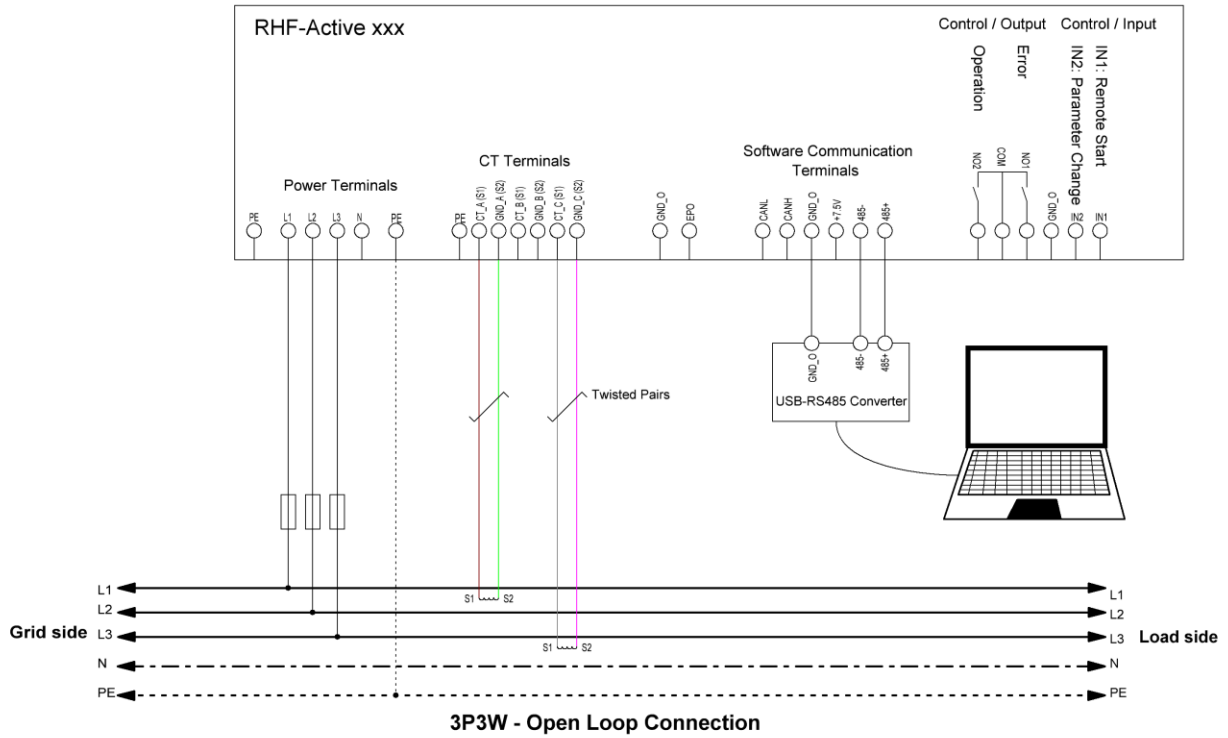

5.3.2 Open Loop - 3P4W wiring

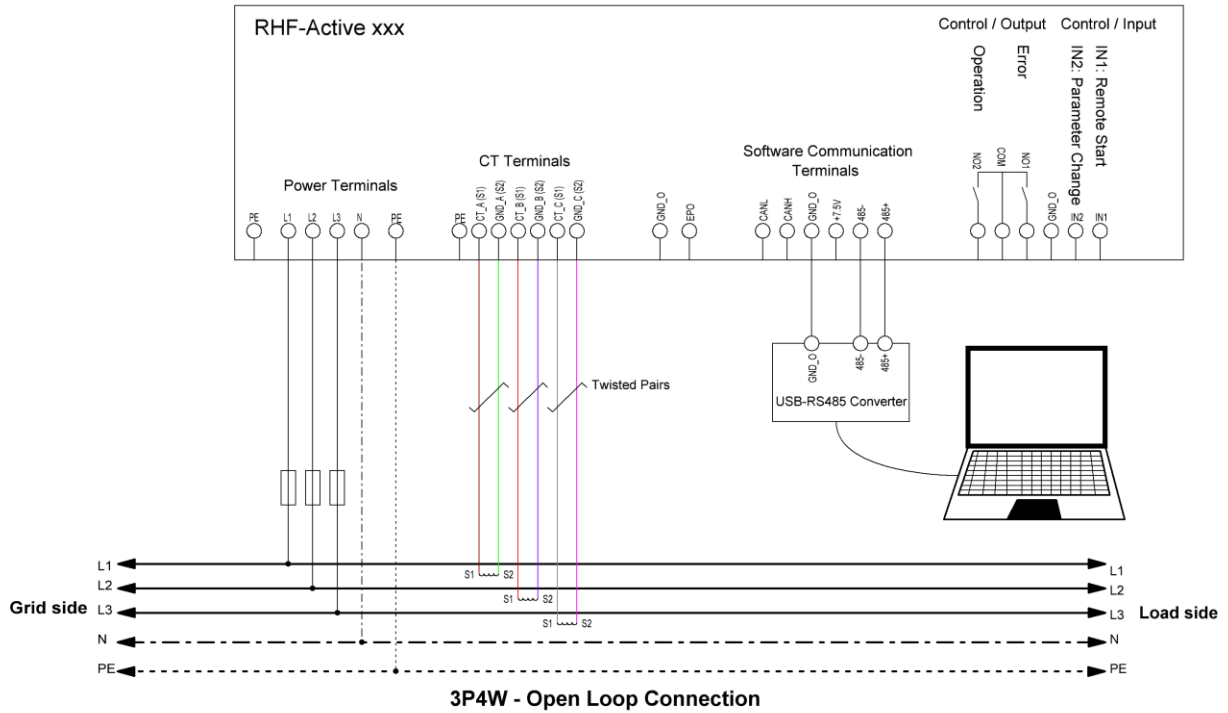

**5.3.3 Close Loop - 3P3W wiring**

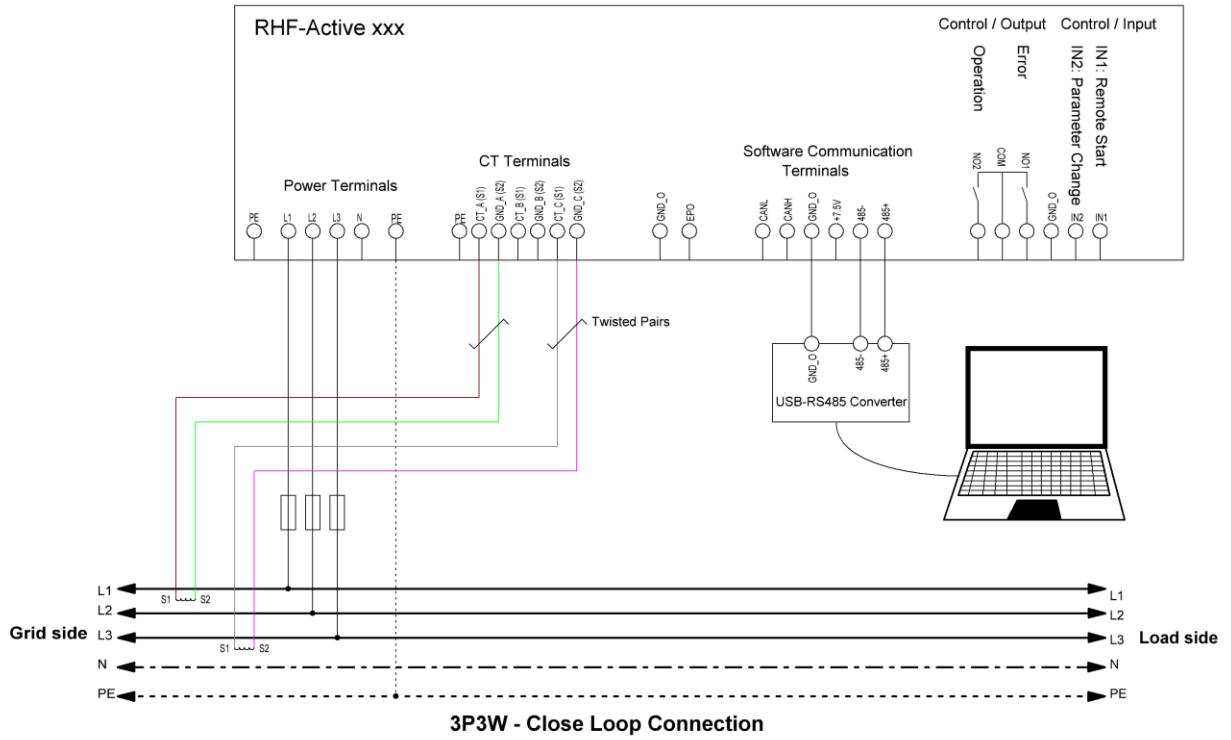

**5.3.4 Close Loop - 3P4W wiring**

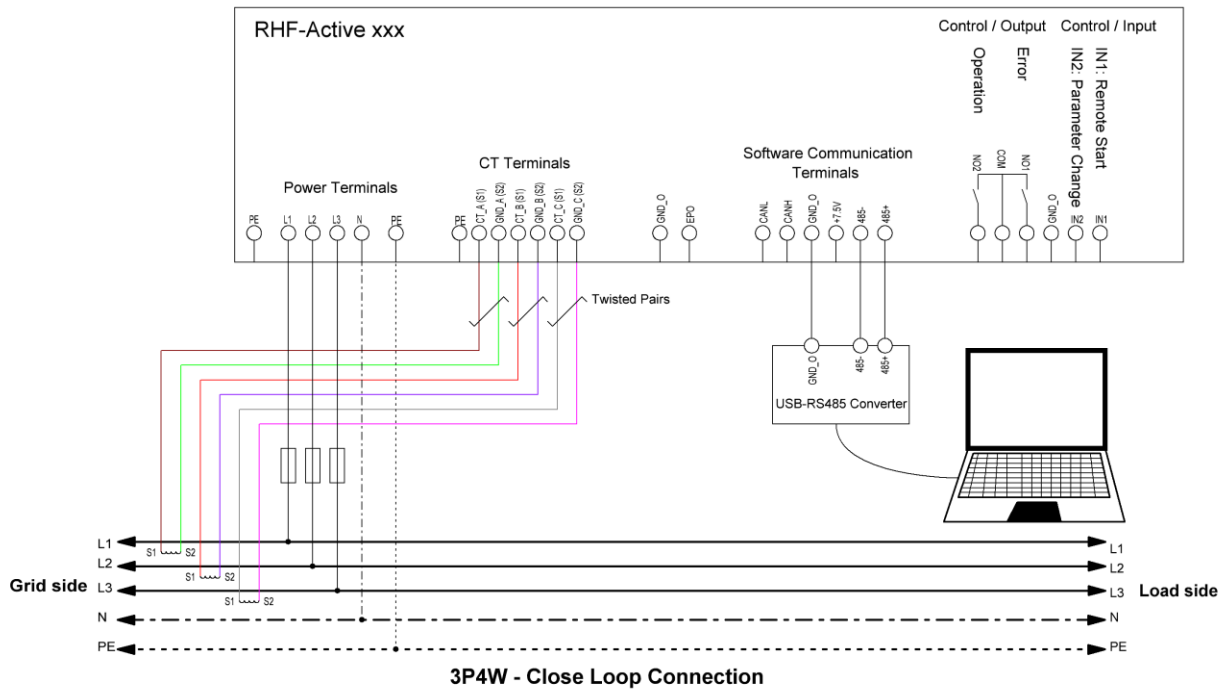

**Remarks:**

**Routing of wires:** The wires between RHF-Active and current transformers must be twisted pair cables. A correct function is only possible if the wiring matches exact the diagram below. If wires are interchanged, the harmonics will not be reduced but amplified. To avoid interchanging of wires it is strongly recommended not to use any wire colour twice.

**Wire cross section:** The cross section of the wires has a significant influence on the quality of the control. Is the cross section to small in relation to the length of the wire, the resulting measurement will be too small to achieve a good control quality and good reduction of harmonics.

$$A = \frac{2 \times d \times v \times I^2 \times \rho}{S}$$

The following values needed to be known:

S = Power of the current transformer (typical 2,5VA)

d = Distance (length of cableway) between RHF-Active and current transformer

v = Twisting factor (typical 1,05)

I = secondary current of the current transformer (typical 5A)

$\rho$  = Rho = specific resistance of copper (  $0,01786 \frac{\text{Ohm} \times \text{mm}^2}{\text{m}}$  )

Example:  $A = \frac{2 \times 2\text{m} \times 1,05 \times 5^2 \times 0,01786 \text{ Ohm} \times \text{m}}{2,5\text{VA} \times \text{mm}^2} = 0,75\text{mm}^2$

**Wiring type:**

A hybrid between 3P3W and 3P4W is not possible. At 3P3W (installation of two current transformers) the neutral must not be connected to the RHF-Active. It is mandatory that the physical installation must match the adjusted method in the software of the RHF-Active. If this is not observed, the reduction of harmonics is not optimal.

### 5.3.3 LED status display



5.3.4 RS-485 and CAN Communication

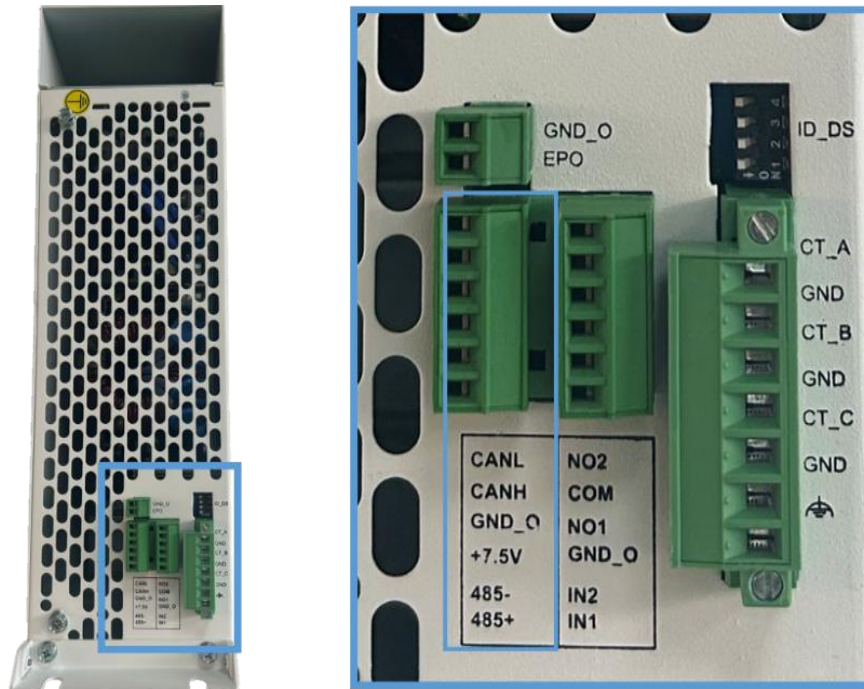

Terminal label	Function
CANL	CAN Bus connection for firmware update (for use of REVCON only)
CANH	
GND_O	GND
+7.5V	Aux supply. For use of REVCON only.
485+	485 Interface for remote control by a computer. A standard-485-communication interface requires screened or twisted wires. If the wire length exceeds 1m, GND must be connected.
485-	

Wiring example:

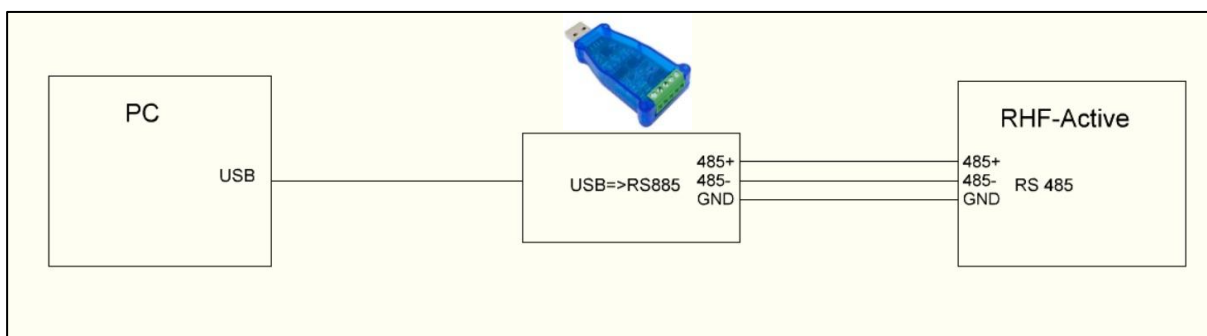

### 5.3.5 Current transformer wiring

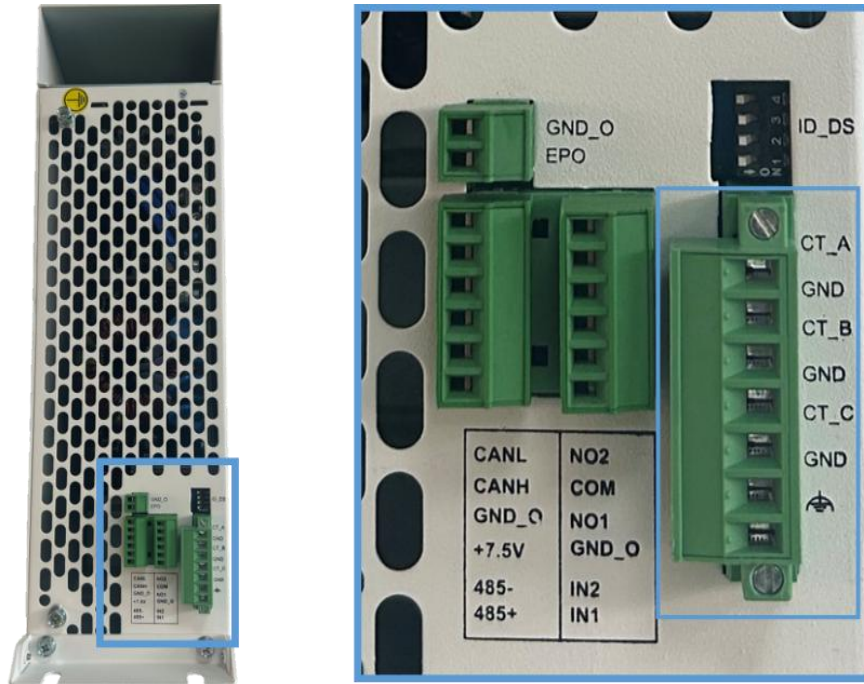

Terminal label	Function / Terminal
CT_A	CT S1 in Phase A (L1)
GND	CT S2 in Phase A (L1.1)
CT_B	CT S1 in Phase B (L2)
GND	CT S2 in Phase B (L2.1)
CT_C	CT S1 in Phase C (L3)
GND	CT S2 in Phase C (L3.1)
PE	Protective wire / screening

Hint: To achieve best performance of RHF-active the pairs CT\_A+GND, CT\_B+GND and CT\_C+GND should be twisted.

### 5.3.6 RHF-Active in parallel wiring

RHF-Active may be connected in parallel without limitation to achieve higher power ratings. It is necessary to adjust the related parameters in the software and do adopt the wiring of the current transformers.

Phase A (L1) is used for reference for the other phases.

**Example Case 1:  
Parallel wiring of two RHF-Active:**

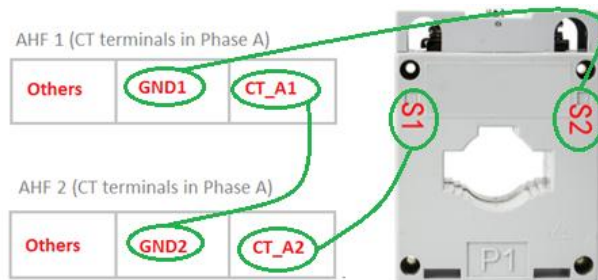

Hint: Like the polarity of S1 and S2, the polarity of P1 and P2 is very important for the correct function. P1 must face to mains supply and P2 (on opposite side of current transformer) must face to the load.

**Example Case 2:  
Parallel wiring of more than two RHF-Active:**

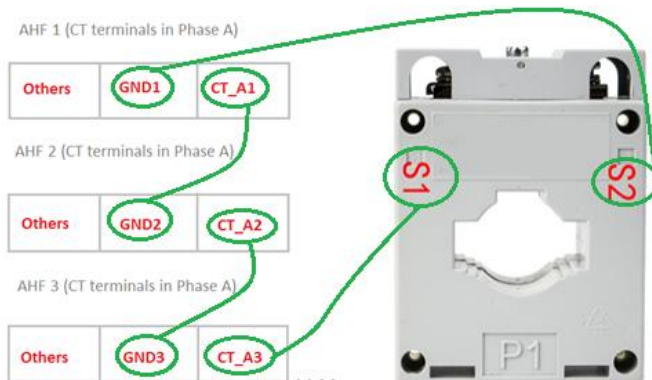

Hint: Like the polarity of S1 and S2, the polarity of P1 and P2 is very important for the correct function. P1 must face to mains supply and P2 (on opposite side of current transformer) must face to the load.

### **5.3.7 Selection of current transformers**

Selection of current transformers depends on the load current of the application. Applicable are current transformers in the range of 5/5 to 10000/5. The transfer ratio must be adjusted in the correlated parameter of the software. For optimal performance, the nominal current of the current transformer must not be much higher than the load current of the application (e.g. load current 95A => current transformer 100A)

### **5.3.8 Modification of wiring when using current transformers with high ratio**

If there is no current transformer with optimal ratio available, at push through transformers the primary conductor may be lead through the transformer two or several times. Not only in this case it is very important to observe that the direction of energy flow in the conductor and the marked direction on the transformer match. The Software adjustment must be in accordance to the final ratio.

If e.g. a 100A CT is used, but the wire is loped through. The setting in the software must be 50A.

5.3.9 EPO and RHF-Active ID

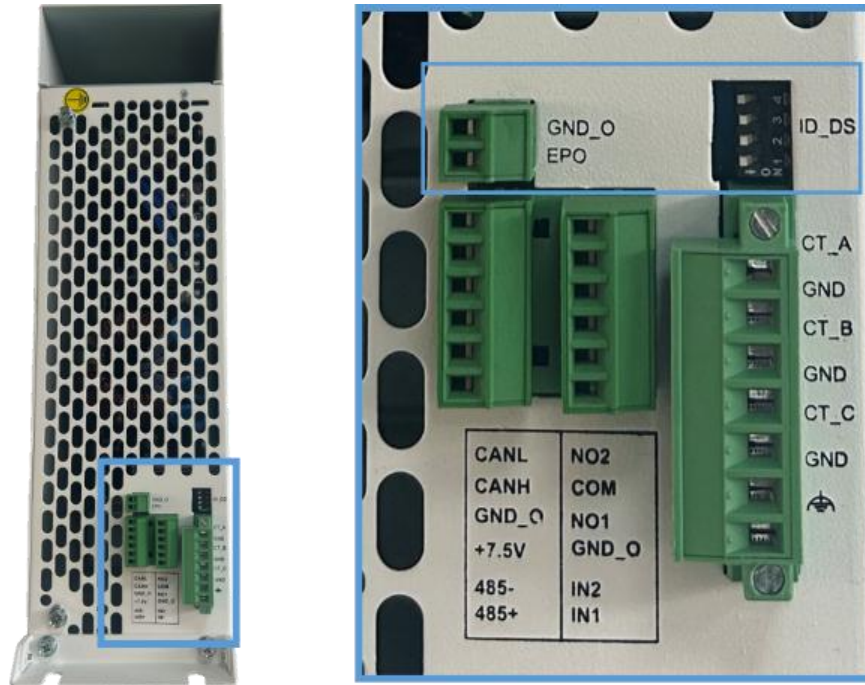

Terminal label	Function
GND_O	EPO connection for usage as part of EMERGENCY OFF line. If the contact to be wired here is closed, the EMERGENCY OFF function is active.
EPO	
ID_DS	Reserved for future purpose

A new RHF-Active will be supplied with a short circuit wire at the EPO connector. This is mandatory to ensure that the RHF-Active will NOT start at first powering up. **If the RHF-Active has not been powered up for >4 months, wait 1 hour before starting it (RUN). This action ensures a prolonged lifetime of the capacitors.** For the detailed storage conditions please see Appendix A on Chapter 9. To start the RHF-Active, switch off the supply voltage, disconnect the EPO connector (or remove the wire) and power it up again. The error will be cleared automatically and the product can be used.



**Stop!**

If RHF-Active is started (RUN) not observing this instruction, the product's lifetime will be affected.



### 5.3.10 Input and output interface

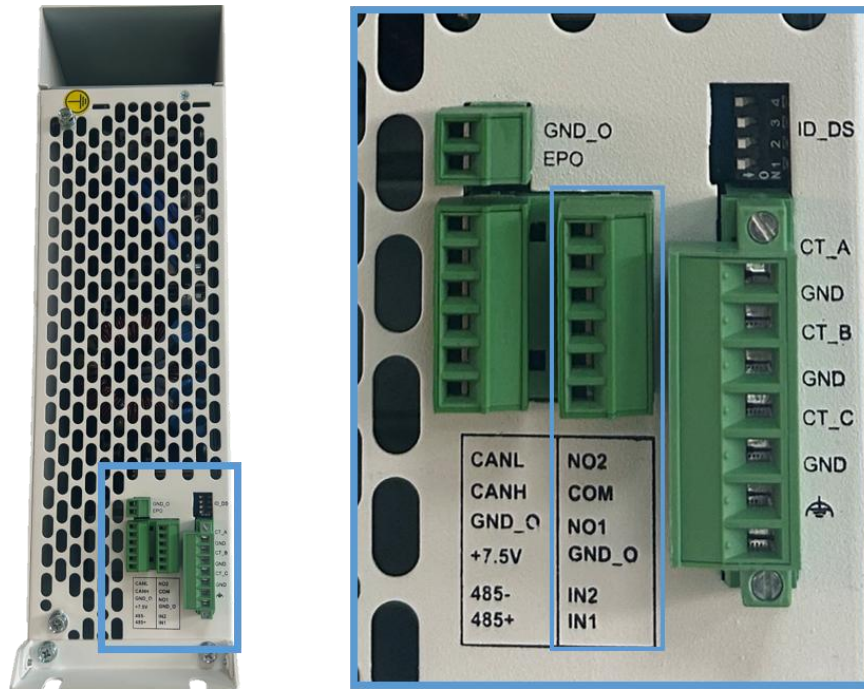

Terminal label	Function
NO2	Relay 2, Normal Open, DC, capacity: 8A/250VAC
COM	Common ground for relay output
NO1	Relay 1, Normal Open, DC, capacity: 8A/250VAC
GND_O	Common ground for DC input
1N1	IN1+ for DC +, recommended input voltage range: 10 ~ 24V DC
1N2	IN2+ for DC +, recommended input voltage range: 10 ~ 24V DC

## 6. Supervision- and control software

### 6.1 What this chapter contains

This chapter contains guidelines for using the supervision and control software. There are hints how to check the parameters before commissioning and how to optimize them during operation.

This chapter has been shortened. For further information regarding connection and commissioning please refer to the RHF-Active commissioning guide.

### 6.2 Introduction in the system

There are two versions of the software:

Software-Version	Suitable for
RHF-Active Configuration V3.2.7 (or higher)	Old RHF-Active 100A
RHF-Active Configuration V3.2.17 (or higher)	RHF-Active 15A, 35A, 55A, 100A, 150A

#### 6.2.1 Log In

For connection of the RHF-Active to the PC the latest RHF-Active PC software should be used.

This can be downloaded from [www.revcon.de](http://www.revcon.de) or requested from [info@revcon.de](mailto:info@revcon.de)

During download of the software, please ensure your antivirus software is not changing the name or delating the exe file: "RHF-Active-SiC.exe". Execute this exe to start the software. The following Login for easy access can be used:

Login: 001

Password: 010101

Higher access level can be requested from REVCON.

## 7. Maintenance and check of hardware

### 7.1 What this chapter contains

This chapter contains instructions for predictive maintenance of the RHF-Active.

### 7.2 Periodicity of maintenance

When installed in an appropriate environment the RHF-Active required minimal maintenance. The recommended maintenance is listed below.

Check	Task	Method
Environment conditions	Check of ambient temperature, humidity, vibrations and for absence of dust, gas, oil mist and water drops	Optical check and measurement of the parameters
	Ensure that no tools or other potentially dangerous components have been placed nearby	Optical check
Voltage	Measure voltage in power and control circuits	Measurement with multimeter
Supply lines	Check of system and cabinet	Check for loosen screws
		Check of absence of sparks, damages, dark colour due to overheating or aging of isolation
		Ensure that no dust or dirt is present
Cooling system	Fan	Check for abnormal sound emission or vibrations
		Check for loosen screws
		Check of absence of dark colour due to overheating or aging
	Air duct	Check for debris in the cooling system
		Optical check or estimation of operation time based on maintenance files
		Fix screws
		Optical check or estimation of operation time based on maintenance files
		Optical check

## 8. Error description and repair

### 8.1 What this chapter contains

This chapter describes known issues and their solutions.

### 8.2 Typical errors and repairs

Error	cause	repair
RHF-Active wrong compensation (THDI rises)	Current transformer	Check wiring and polarity
	System settings	Check transformer ratio
RHF-Active insufficient compensation (THDI decreases but is higher than expected)	Phase angle	Setting the phase angle compensation with patience and carefully step by step, Trial and error iteration
	Low impedance	Low impedance of the connection result in very harmonic levels before compensation. It is highly recommended to install impedance as first counter measurement against harmonics (for Drives basically DC or AC chokes).
Error signal (red LED)	System settings	Observe chapter 5.3.9! Check for first error than for second
No communication	Software settings	Improve baud rate and/or interface selection

Further possible alerts and troubleshooting can be found in the RHF-Active commissioning guide.

## 9 Appendix A

### 9.1 Storage Conditions

Storage Humidity	Storage Temperature	Storage Packaging	Storage time
<95%	5 ~ 35°C	Original sealed packaging	2-Years
<95%	35 ~ 70°C	Original sealed packaging	1-Year
<75%	5 ~ 35°C	Opened	1-Year
75% ~ <95%	5 ~ 25°C	Opened	2-Months
75% ~ <95%	25 ~ 70°C	Opened	Cannot be stored long-term under these conditions

## 10 Revcon Product Overview

### 10.1 Revcon Product

#### 1. REVCON® RLD

Power feedback units for short time operation (light-duty)  
(Crane systems, discontinuous centrifugal, etc.)

#### 2. REVCON® RHD

Power feedback units for continuous operation (heavy-duty)  
(Engine test beds, escalators, wind energy plants, elevators etc.)

#### 3. REVCON® RFE

Power feed and feedback units for continuous operation  
(Engine test beds, escalators, wind energy plants, elevators etc.)

#### 4. REVCON® RSU

Step- up converter for the generation of a current controlled, high output voltage from a lower input DC voltage.

#### 5. REVCON® RSD

Step- down converter for the generation of a decreased output voltage from a higher DC voltage (AC input is also possible).

- Voltage controlled: A free selectable output voltage in wide limits

The required output voltage can be adjusted by set-point (0 ... 10V)

- Current controlled: A lower output voltage that adjusts free in dependence of the load

The required output current can be adjusted by set-point (0 ... 10V)

#### 6. REVCON® EDC

Power supply module for multiple motor applications (supply of multiple drive controllers) without generator- operation

**7. REVCAN® RHF-8P/5P**

Revcon Passive Harmonic filter. Reduces the harmonic distortion of a drive to <5% or 8%

**8. REVCAN® RHF-Hybrid**

Combines the advantages of active and passive harmonic filter.

All products are available for 400V line voltage, the most also for 230V, 400V, 460V, 500V, 600V and 690V! According to the product power from 4 to 440kW can be transmitted, whereby the most products are appropriate for parallel connection, so that power ratings until the megawatt range can be achieved!

## 10.2 Revcon Contact

**Eltroplan-REVCAN Elektrotechnische Anlagen GmbH**

**Edisonstraße 3**

**D-59199 Bönen**

**Phone +49 (0)2383 920 22 22**

**Fax +49 (0)2383 920 22 66**

**E-Mail [info@REVCAN.de](mailto:info@REVCAN.de)**

**Web [www.REVCAN.de](http://www.REVCAN.de)**