



CP Automation  
Keeping industry  
in motion

Uninterruptible Power Supply UPS

**Cover CORE ONE**

**1 - 3 kVA / kW**

User manual

## Contents

1. Safety rules.....	1
2. Transportation, UPS unpacking.....	3
2.1. Horizontal installation in a 19" rack.....	3
3. Design and connection.....	4
3.1. Back panel of UPS .....	4
3.2. Connection of internal batteries.....	5
3.3. Connection of external batteries.....	5
3.4. Power connection .....	6
3.5. Connecting loads to the UPS output.....	6
3.6. Remote REPO switch connection.....	7
3.7. Connection of communication options .....	7
3.8. TVSS connection.....	7
4. LCD display support .....	8
4.1. Function keys .....	8
4.2. LCD panel .....	8
4.3. Alarm signals .....	10
4.4. LCD display letter abbreviations .....	10
4.5. Settings of UPS.....	11
4.6. Description of the UPS operating modes .....	14
4.7. UPS warnings and audible alarms.....	15
4.8. Error codes.....	16
5. UPS operation .....	17
5.1. UPS turning on .....	17
5.2. UPS turning off.....	17
5.3. Battery test .....	17
5.4. Mutes the audible alarm.....	17
5.5. Software installation.....	17
6. UPS working environment and operation .....	18
6.1. Working conditions.....	18
6.2. The storage conditions.....	18
6.3. Battery replacement .....	18

## 1. Safety rules

This manual provides information on the safe use of the UPS. Before unpacking and installing the power supply, read its contents and follow its recommendations.

	<b>MET STANDARDS - EXECUTION</b>
EN 62040-3	Uninterruptible Power Systems (UPS): Performance Methods and Test Requirements.

	<b>STANDARDS MET - ELECTROMAGNETIC COMPATIBILITY</b>
EN 62040-2 :2018 C2	Uninterruptible Power Supply Systems (UPS): Electromagnetic Compatibility.
EN 61000-2-2 :2002	Electromagnetic Compatibility (EMC): Environment. Compatibility Levels for IF Conducted Disturbances and signaling in public low-voltage power supply systems.
EN 61000-4-2 :2009	Electromagnetic compatibility (EMC): Methods of testing and measurement - testing of resistance to electrostatic discharges.
EN 61000-4-3 :2006 +A2 :2010	Electromagnetic Compatibility (EMC): Testing and Measurement Methods - Radio Frequency Electromagnetic Field Immunity Test.
EN 61000-4-4 :2012	Electromagnetic Compatibility (EMC): Testing and Measurement Methods - Immunity testing against series of fast electrical transients.
EN 61000-4-5 :2014	Electromagnetic Compatibility (EMC): Testing and Measurement Methods - Surge Immunity Test.
EN 61000-4-6 :2014	Electromagnetic compatibility (EMC): Methods of testing and measurement - Immunity to conducted disturbances induced by radio frequency fields.
EN 61000-4-8 :2010	Electromagnetic compatibility (EMC): Methods of testing and measurement - Testing the resistance to magnetic field with the frequency of the power grid.
The device complies with Directive 2014/30/EC (EMC).	

	<b>STANDARDS MET - SAFETY</b>
EN 62040-1 :2019	Uninterruptible Power Systems (UPS): General and UPS safety requirements.
EN 60950-1:2006 IEC 60417	Information technology devices. Security. Symbols used on devices
The device complies with Directive 2014/35/EC (LVD).	

- Keep this manual! The manual contains important instructions for the use of the UPS, which should be followed during the installation and use of the UPS device and batteries.
- Condensation may occur if the UPS is cold and is brought into a warm room. Therefore, you should wait at least 2 hours until it starts.
- To reduce the risk of electric shock, the UPS should be installed in a dust-free room with appropriate temperature and humidity. The ambient temperature must not exceed 40°C.
- Do not install the power supply in a place exposed to direct sunlight or other sources of heat.
- Do not connect devices to the UPS output that may overload it, e.g. laser printers, electric heaters, etc.
- Cables should be connected and placed in such a way that no one can accidentally step on or disconnect them.
- The UPS must be connected to a socket with a pin with a functional protective conductor (PE).
- Do not block the ventilation openings in the UPS. Make sure that the vents are uncovered and there is a minimum of 25 cm of free space for free ventilation.
- The UPS power socket should be protected by a suitable overcurrent circuit breaker.
- The UPS has its own battery power source, so there may be voltage at the output sockets even though the UPS is not connected to the mains.
- Batteries should be handled by trained personnel who are familiar with the use of batteries and take appropriate precautions when using them.
- If it is necessary to replace the batteries, use batteries with the same number and the same parameters, i.e. rated voltage, capacity and dimensions.

---

***ATTENTION! Do not throw batteries into fire. The battery may explode.***

---

---

***ATTENTION! Do not open or damage the battery. The released electrolyte is harmful to the skin and eyes. It can be toxic.***

---

- The battery may present a risk of electric shock. Observe the following precautions when working with batteries:
  - Remove watches, rings and other metal objects from your hand.
  - Use tools with insulated handles.
  - Wear rubber gloves and boots.
  - Do not place tools or metal parts on top of the battery.
  - Disconnect the battery charging source before connecting or disconnecting the battery terminals.
- Check that the battery is not inadvertently grounded. If present, remove the source of the ground fault. Contact with any part of a grounded battery can cause electric shock.

## 2. Transportation, UPS unpacking

Check carefully that the carton and contents are not damaged. If any damage is found, immediately inform the transport company and the distributor of the power supply. Do not throw away the power supply packaging.

1. If no damage is found, carefully open the carton.
2. Unpack all protective elements (sponges, fillers).
3. Carefully remove the UPS from the protective film and place it on a clean, flat and stable surface.

---

*Only transport the UPS in its original packaging to prevent mechanical damage, shocks and impacts.*

---

### 2.1. Horizontal installation in a 19" rack

The CORE series power supply can be mounted in a 19" Rack. Both the UPS and the battery module require 2U space for installation. Each item requires optional brackets (rack rails) for mounting in the rack.

For proper installation, you must:

Step 1

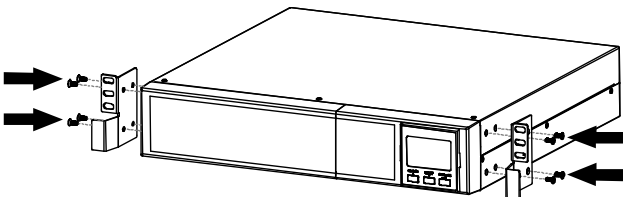

Step 2

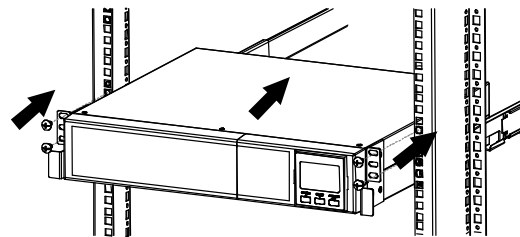

### 2.2. Vertical installation (Tower)

To install the power supply in the Tower position, use special supports that secure the power supply and enable its stable positioning in a vertical position. In order to place the power supply correctly, you should:

Step 1

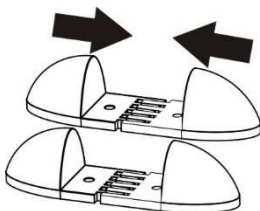

Step 2

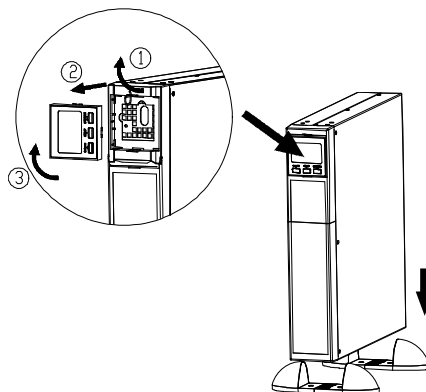

Step 3

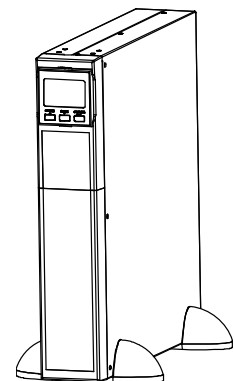

### 3. Design and connection

#### 3.1. Back panel of UPS

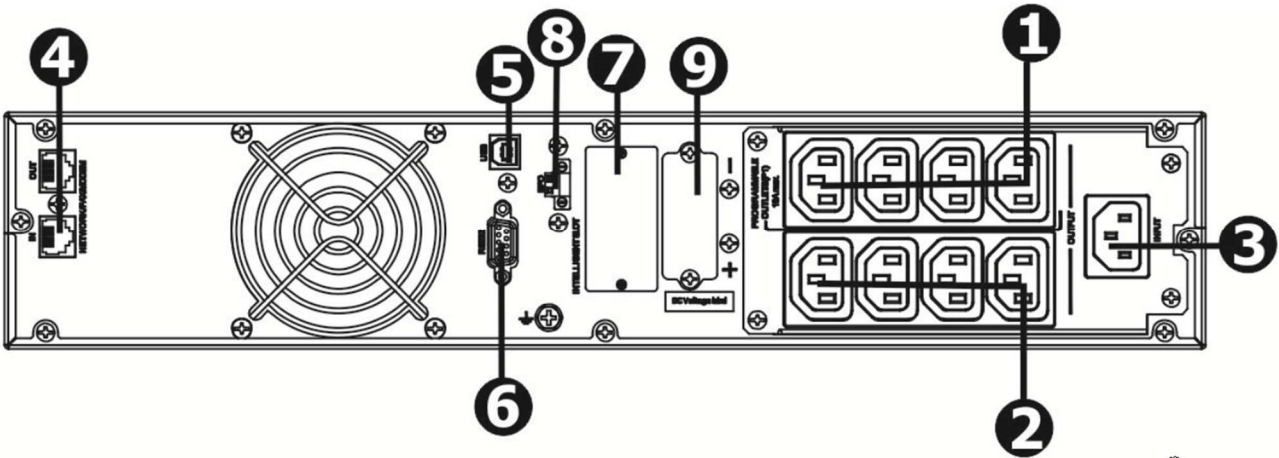

UPS COVER CORE ONE 1K

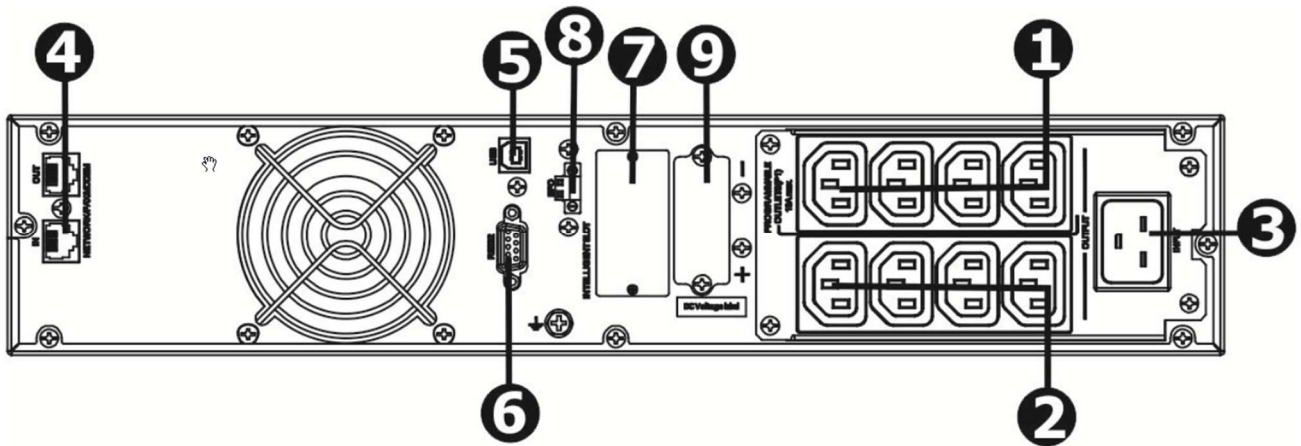

UPS COVER CORE ONE 2K

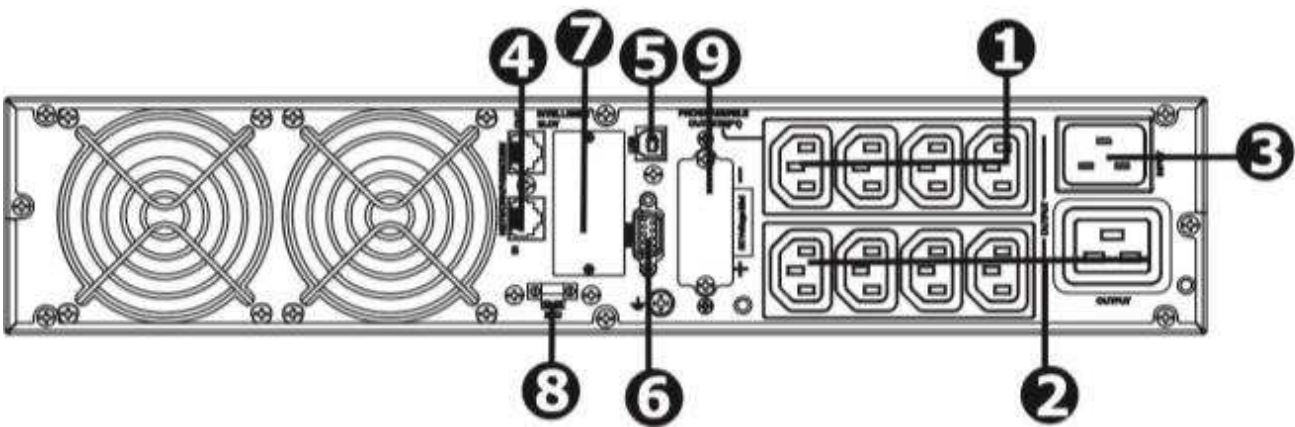

UPS COVER CORE ONE 3K

1. Programmable output sockets: can be switched off, intended for less critical loads.
2. Fixed output sockets: for connecting critical loads. Voltage is present on these outlets whenever the UPS is operating in normal or battery mode.
3. Power socket.
4. TVSS data line surge protection (network, fax, modem).
5. USB port.
6. RS-232 port.
7. Communication slot.
8. Remote Emergency Power Off (EPO) input.
9. Additional battery connector.

### 3.2. Connection of internal batteries

For safe transportation of the UPS, the battery cables inside the UPS are disconnected. Before installing the UPS, please follow the instructions below to connect the batteries.

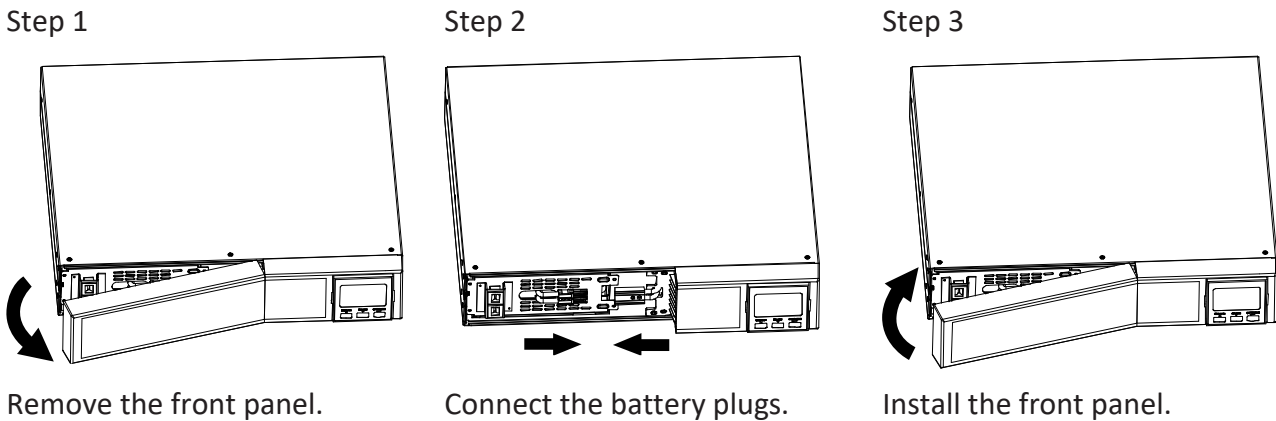

### 3.3. Connection of external batteries

Connect one end of the battery cable to the appropriate socket on the rear panel of the UPS, the other end to the socket located on the battery module. In the case of more battery modules, the remaining connections are made between the supplied battery modules as shown in the figure below.

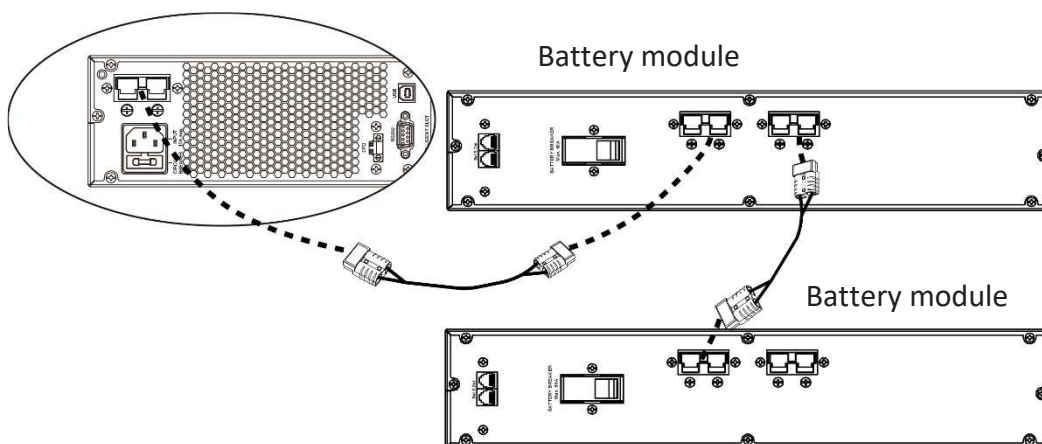

---

*If additional battery modules or external batteries are connected, the UPS should check and, if necessary, correct the setting of the connected battery capacity.*

---

---

*After connecting the external battery module, switch on the battery circuit by lifting the protection on the back cover of the battery module (Battery Breaker).*

---

---

*External batteries that are not installed in the original battery modules should have their own protection (fuse or circuit breaker).*

---

### **3.4. Power connection**

The power supply should be connected to an electrical outlet equipped with a pin with an operational protective conductor using the cable supplied by the manufacturer. The electrical socket to which the power supply is connected should be protected by a circuit breaker appropriate to the power of the UPS: 10A for 1kVA, 16A for 2kVA and 16A for 3kVA. It is recommended to use a separate socket to power the UPS, protected by its own circuit breaker.

### **3.5. Connecting loads to the UPS output**

The UPS is equipped with standard IEC 320 sockets. Connecting receivers requires the use of standard IEC 320 C13 - C14 (10A) or IEC 320 C19-C20 (16A) cables. The UPS is equipped with 8 IEC 320-C13 (10A) sockets and 1 16A (IEC 320-C19) socket.

The UPS has two groups of output sockets: programmable sockets and fixed sockets.

It is recommended to connect critical loads to group 2 sockets, and less important loads to group 1 programmable sockets (see description 3.1.).

In the event of a power failure, you can extend the working time of critical loads (connected to the group 2 sockets) on the battery by reducing the working time of devices connected to the programmable sockets (group 1). Programming the working time of devices connected to the programmable sockets is available from the level of the UPS configuration menu.

---

*Do not connect devices to the UPS output that may overload it, e.g. laser printers, electric heaters, heaters, etc.*

---

---

*Cables should be connected and placed in such a way that no one can accidentally disconnect them.*

---

---

*Do not connect loads with a current greater than 10A to IEC 10A output sockets.*

---

---

*Do not use output cables longer than 10 meters.*

---

### 3.6. Remote REPO switch connection

The UPS is equipped with an EPO port for connecting a remote REPO (Remote Emergency Power Off) switch.

By default, the EPO port is configured as NC (normally closed), EPO is activated by breaking the connection between Pin 1 and Pin 2 (jumper removed).

You can change the EPO configuration to NO (Normally Open) from the Setup Menu on the LCD. Changing the configuration to NO requires removing the jumper between Pin 1 and Pin 2.

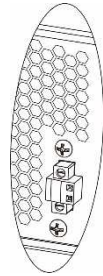

### 3.7. Connection of communication options

The UPS has three communication ports:

USB



RS-232

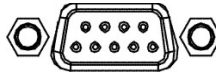

Slot SNMP/AS-400

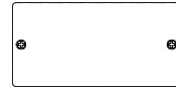

To enable automatic management and monitoring of the UPS, connect the USB cable supplied with the UPS to the USB port on the UPS on one end and the USB port on the computer on the other.

The software supplied with the UPS allows you to automate the processes of switching on/off the receivers connected to the UPS depending on the events that occur on the UPS (e.g. power failure, low battery charge, overload, etc.). The software also allows for ongoing monitoring of operation and registration of the history of UPS events.

The UPS also has a slot for additional cards, which enables retrofitting with an SNMP network card for remote communication via the Internet or an AS-400 relay contact card for communication with external supervision systems, e.g. BMS.

Attention! RS-232 and USB port cannot be used simultaneously.

### 3.8. TVSS connection

In order to protect the data lines (Internet/fax/telephone) against surges, the UPS is equipped with an additional TVSS filter. The protected device should be connected to the sockets located on the rear panel of the power supply, marked as in the figure beside.



## 4. LCD display support



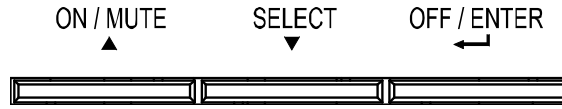





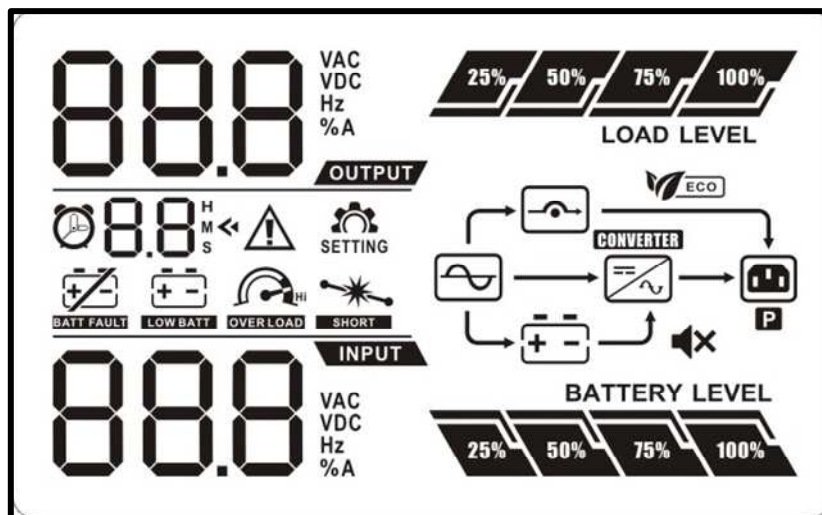





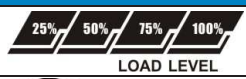



### 4.1. Function keys

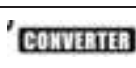
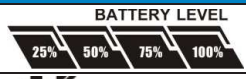

Button	Function
<b>ON/MUTE</b> ▲	<ul style="list-style-type: none"> <li>Turn on the UPS: press and hold for at least 2 seconds.</li> <li>Alarm Silence: When the UPS is running on battery, press and hold for at least 3 seconds to turn the buzzer on or off. Does not apply when there is an alarm condition.</li> <li>Up Arrow: Key to scroll up to the previous line in the UPS menu.</li> <li>Enable self-test mode: press and hold for 3 seconds during normal UPS operation.</li> </ul>
<b>OFF/ENTER</b> ↵	<ul style="list-style-type: none"> <li>UPS shutdown: press and hold for 2 seconds. Depending on the configuration of the Bypass mode in the menu: the UPS will switch to Stand-By mode (no output voltage) or Bypass mode (output voltage from the municipal network).</li> <li>Confirmation of selection: press the key to confirm the selection in the menu.</li> </ul>
<b>SELECT</b> ▼	<ul style="list-style-type: none"> <li>Switching between display information: press to switch between information displayed on the panel, such as voltage, frequency, battery voltage, etc.</li> <li>Settings menu: press and hold for 5 seconds to enter the UPS settings (configuration) menu. This function is only available when the UPS is in Bypass or Stand-By mode.</li> <li>Down Arrow: Key to scroll down to the next line in the UPS menu.</li> </ul>
<b>ON/MUTE</b> ▲ + <b>SELECT</b> ▼	<ul style="list-style-type: none"> <li>Switching to Bypass: During normal operation of the UPS, press the [ON/MUTE] and [SELECT] keys simultaneously for 5 seconds, the UPS will enter Bypass mode. Transfer to Bypass is not possible if the supply voltage is outside the acceptable range.</li> <li>Exit the menu setting mode or go to the upper menu level: In the setting menu mode, press the [ON/MUTE] and [SELECT] keys simultaneously for 0.2 seconds to go to the upper menu level or exit the setting mode menu.</li> </ul>

### 4.2. LCD panel



LCD panel	Function
<b>Autonomy time information</b>	
	Displays the estimated working autonomy time of the power supply H: hours, M: minutes, S: seconds
<b>Configuration and error information</b>	
	Displays the parameter value. Description of possible indications is contained in subchapter 4.5.
	Displays an error or warning code. Error and warning codes are described in sections 4.7. and 4.8.
<b>Sound signaling</b>	
	Indicate that the beeper is off
<b>Output information</b>	
	Indicates output parameters like voltage, frequency, current: VAC: voltage AC [V], Hz: frequency [Hz], A: current [A]
<b>Informacje o obciążeniu</b>	
	Indicates load level 0-24%, 25-49%, 50-74%, and 75-100%.
	Indicates an overload condition.
	Indicates a short circuit condition on the UPS output.
<b>Information about programmed outputs</b>	
	Indicates whether a group of programmable sockets is configured.
<b>Operating mode information</b>	
	Indicates that the UPS is connected to the utility grid.
	Indicates that the batteries are connected to the UPS.
	Indicates that Bypass is active.
	Indicates that ECO mode is on.
	Indicates that the UPS inverter is running.
	Indicates that the output voltage is present.
	Indicates that the UPS is in frequency converter mode.
<b>Battery information</b>	
	Indicates 0-24%, 25-49%, 50-74%, and 75-100% charge.
	Indicates a damaged battery.
	Indicates a low battery level.
<b>Input and battery information</b>	
	Displays input voltage, frequency and battery voltage: VAC: AC voltage [V], VDC: DC voltage [V], Hz: frequency [Hz]

### 4.3. Alarm signals

Battery mode	Beeps every 5 seconds.
Low voltage of battery	Beeps every 2 seconds.
Overload	Beeps every 1 second.
Error	Continuous signal.
Bypass mode	Beeps every 10 seconds.

### 4.4. LCD display letter abbreviations

Abbreviation	Display indication	Meaning
AC	AC	EPO NO - normally open (active after short circuit)
AO	AO	EPO NC - normally closed (active when open)
BR	bT	Battery change
CH	CH	Charger
DIS	di S	Disable
EAT	EAT	Estimated autonomy time
EE	EE	Error EEPROM
ENA	ENA	Enable
EP	EP	EPO - emergency shutdown (necessary restart)
ESC	ESC	Escape
FU	FU	Bypass frequency unstable
HLS	HLS	High voltage level
LLS	LLS	Low voltage level
OI	OI	Input current too high
OK	OK	OK!
ON	ON	Turning on
RAT	rAT	Current time of battery operation
SD	Sd	Shut-Down
SF	SF	Phase - neutral connection sequence error
TP	tP	Temperature

## 4.5. Settings of UPS

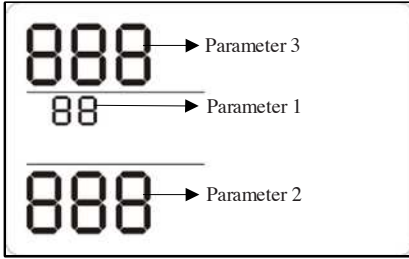

The configuration menu is active when the UPS is turned off (Stand-by mode) or in Bypass mode. To enter the configuration menu, press the SELECT key for 5 seconds as described in chapter 4.1.

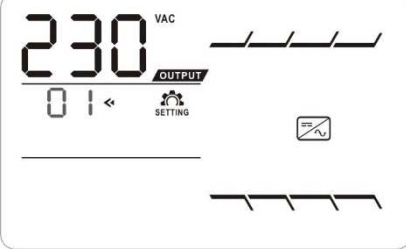
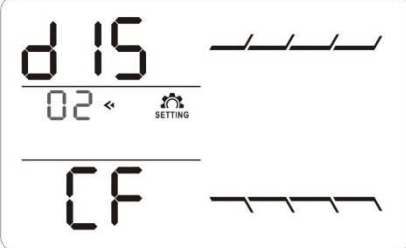
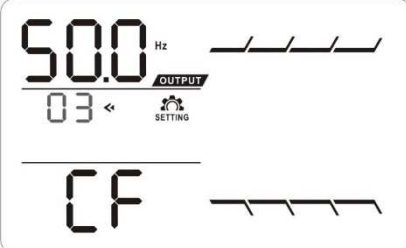
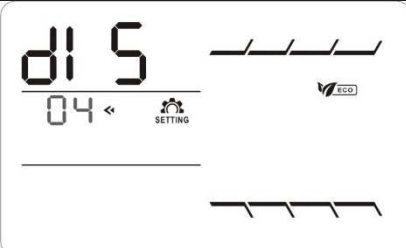
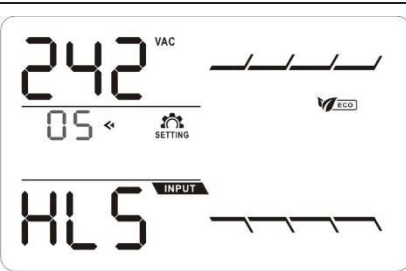

Parameter 1: number of the next menu item.

Parameter 2 and Parameter 3: values of a given parameter (e.g. 230Vac – output voltage value) or configuration.

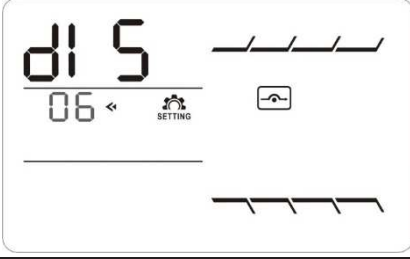
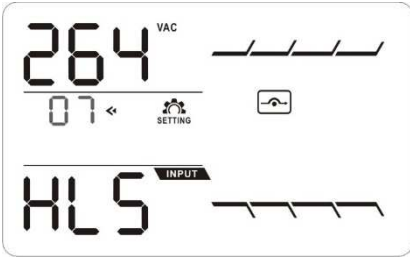
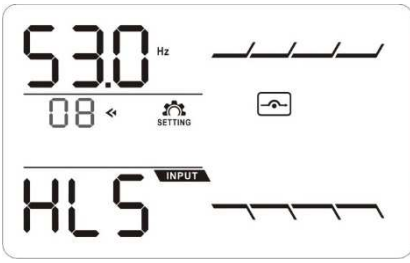
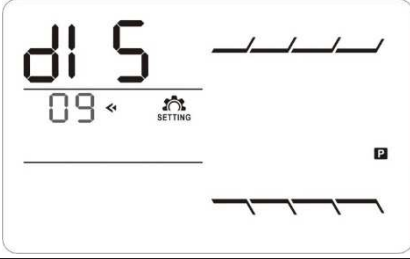
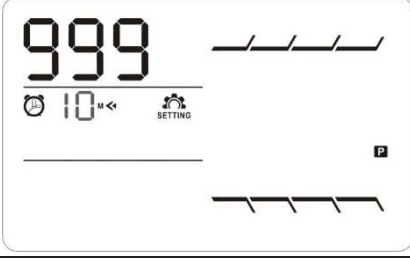
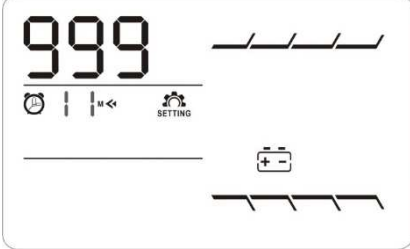
Display status	Settings
<b>01 - Setting the output voltage value</b>	
	200: indicates 200Vac output voltage 208: indicates 208Vac output voltage 220: indicates 220Vac output voltage 230: indicates 230Vac output voltage (default) 240: indicates 240Vac output voltage
<b>02 – Frequency converter available/unavailable</b>	
	ENA: Converter function available DIS: Converter function unavailable (default)
<b>03 - Frequency setting</b>	
	Battery frequency setting: BAT 50: output frequency 50Hz BAT 60: output frequency 60Hz When the UPS works as a converter, you can select the voltage frequency: CF 50: output frequency 50Hz CF 60: output frequency 60Hz
<b>04 – ECO Mode</b>	
	Economy mode availability setting (ECO mode) ENA: ECO function available DIS: ECO function unavailable (default)
<b>05 – Voltage tolerance range in ECO mode</b>	
	Settings of the lower and upper limits of the supply voltage for ECO mode.  HLS: upper supply voltage range. Using the arrow keys, it is possible to select the range +7V ÷ +24V from the nominal value, e.g. 230V (default +12V).  LLS: lower supply voltage range. Using the arrow keys, it is possible to select the range 77V ÷ -24V from the nominal value, e.g. 230V (default -12V).

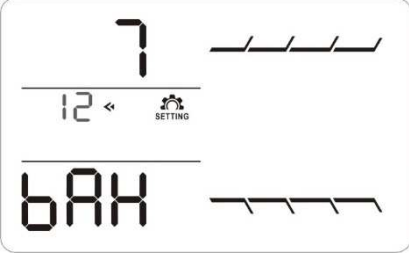
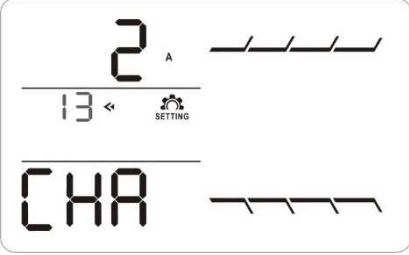
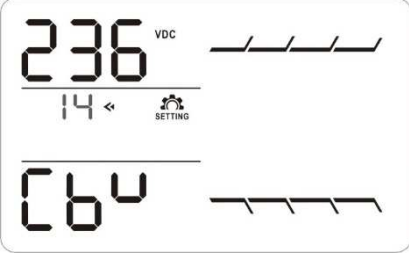
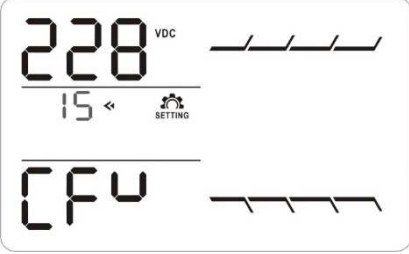
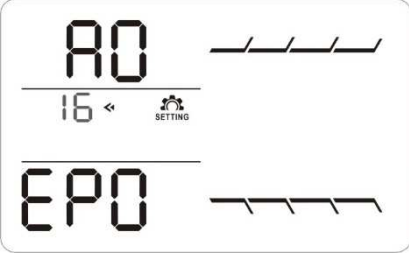
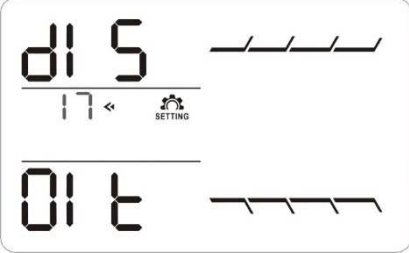
<p>06 – Bypass availability when the inverter is off</p> 	<p>Set the availability of Bypass when the UPS is turned off.          ENA: Bypass available          DIS: Bypass disabled (default)</p>
<p>07 – Bypass voltage tolerance range</p> 	<p>Setting the lower and upper limits of the supply voltage for Bypass. Exceeding the declared voltage thresholds causes unavailability of the Bypass track.</p> <p>HLS: Bypass voltage upper threshold. Using the arrow keys, it is possible to select the voltage 230V ÷ 264V (default 264V).</p> <p>LLS: Bypass voltage lower threshold. Using the arrow keys, it is possible to select the voltage 170V ÷ 220V (default 170V).</p>
<p>08 – Bypass frequency tolerance range</p> 	<p>Setting the lower and upper limits of the supply voltage frequency for Bypass. Exceeding the declared frequency thresholds causes unavailability of the Bypass path.</p> <p>HLS: Bypass frequency upper threshold. Use the arrow keys to select 51Hz ÷ 55Hz (default 53Hz).</p> <p>LLS: Bypass frequency low threshold. Use the arrow keys to select 45Hz ÷ 49Hz (default 47Hz).</p>
<p>09 – Programmable group of output sockets</p> 	<p>ENA: Socket programming function available          DIS: Socket programming not available (default)</p>
<p>10 - Setting the voltage availability time on the programmable sockets</p> 	<p>Setting the working time limit of devices connected to the programmable sockets 0 - 999 minutes in the battery mode. The time is counted from the moment the UPS enters the battery operation mode (999 minutes by default).</p>
<p>11 - Battery autonomy time limitation</p> 	<p>Parameter 2: Setting the maximum battery life 0 - 999 minutes for critical (non-programmed) outlets.</p> <p>DIS: Restriction lock. Autonomy depends on battery capacity. (default)          Attention! Setting the value to "0" means an autonomy of 10 seconds.</p>

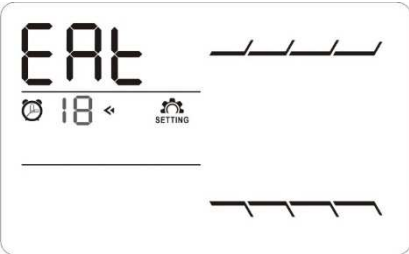
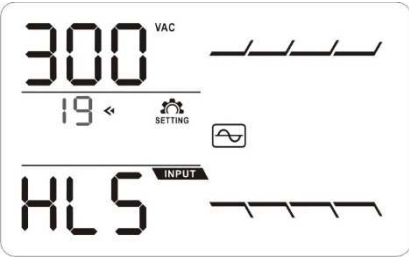
<b>12 - Setting the total battery capacity</b>	
	<p>Parameter 2: Set the capacity of the installed batteries [Ah].</p> <p>7 - 999: Total battery capacity in Ah.          In the case of several strings, the total capacity of the installed batteries must be stated</p>
<b>13 – Charging current limitation</b>	
	<p>Setting the maximum battery charging current.          1/2/3/4/8 A: Maximum battery charging current (default 2A).</p> <p>The maximum battery charging current should be in the range of 0.1C-0.3C. It is recommended to set the value around 0.1C.          E.g. for a battery: 9Ah*0.1=0.9A set to 1A;          45Ah*0.1=4.5A set to 4A</p>
<b>14 – Boost charging voltage setting (equalization voltage)</b>	
	<p>Setting the charging voltage value in boost mode.          225-240: charging voltage value x 0.01V/cell          (default 236 - means 2.36V/cell).</p>
<b>15 – Float charging voltage setting (float voltage)</b>	
	<p>Setting the charging voltage in float mode.          220-233: charging voltage value x 0.01V/cell          (default 228 - means 2.28V/cell).</p>
<b>16 – EPO operating logic setting</b>	
	<p>Setting the operation logic of the EPO input.</p> <p>AO: Active open - indicates the state of the EPO pins in the NC configuration (normally closed). Open means EPO is activated (default).</p> <p>AC: Active Closed - indicates the state of the EPO pins in the NO (normally open) configuration. Closing the connection means EPO is activated.</p>
<b>17 – Output isolation transformer</b>	
	<p>ENA: An output transformer can be used.          DIS: Output transformer cannot be used (default).</p>





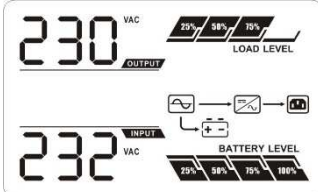
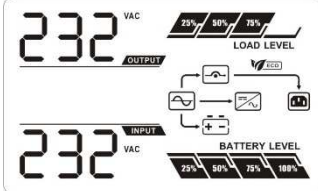
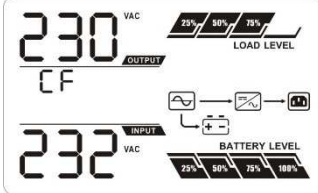
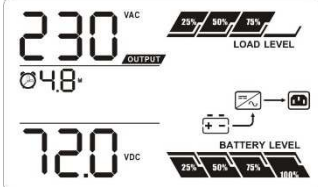

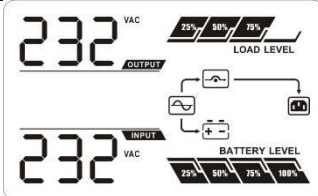
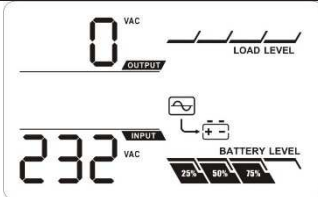
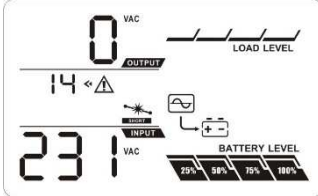







18 – Display of autonomy time during battery operation	
	<p>EAT: Remaining battery life is displayed (default). RAT: the working time elapsed since the power failure is displayed.</p>
19 – Acceptable input voltage range	
	<p>Settings for the lower and upper limits of the supply voltage for the UPS. Exceeding the declared voltage thresholds results in battery operation.</p> <p>HLS: high voltage threshold. Use the arrow keys to select 280/290/300V (default 300V). LLS: lower voltage threshold. Use the arrow keys to select 110/120/130/140/150/160V (default 110V).</p>
00 – Exit the settings menu	
	<p>Exits the UPS configuration menu.</p>

#### 4.6. Description of the UPS operating modes





Working mode	Description	Display status
Normal mode (On Line)	If the supply voltage is within tolerance, the UPS supplies the loads directly from the mains. In this mode, after the battery is fully charged, the fans are turned off to increase the efficiency of the device.	
ECO mode	If the supply voltage is within tolerance, the UPS operates in Bypass mode, the batteries are charged, but the inverter is in Stand-by mode, which increases efficiency and reduces operating costs.	
Frequency converter mode	If the frequency of the supply voltage is within the range of 40÷70Hz, it is possible to set a fixed value of the output voltage frequency of 50 or 60Hz. In this mode, the batteries are also charged.	
Battery mode	In the event of a power failure or when the input voltage is out of tolerance to maintain the output voltage within the required tolerance, the UPS transfers to battery operation. A beep sounds every 5 seconds.	

Bypass mode	If the supply voltage is within the acceptable range and an overload or any other event occurs, the UPS will transfer to Bypass mode. A beep sounds every 10 seconds.	
Stand-by mode	The UPS is off, there is no output voltage, but the batteries are being charged.	
Alarm	In emergency mode, the UPS indicates the error code and icons associated with the event.	

#### 4.7. UPS warnings and audible alarms

Warning	Icon (flashing)	Code	Sound signal
Low battery voltage			Every 2 seconds
Overload			Every 1 second.
Batteries not connected			Every 2 seconds
Battery overcharged			Every 2 seconds
Input current too high		0I	2 times every 10 seconds
Phase error (phase/neutral)		SF	Every 2 seconds
Active EPO (Fire Shutdown)		EP	Every 2 seconds
Overheating		EP	Every 2 seconds
Charger damaged		CH	Every 2 seconds
Battery damage			Every 2 seconds. (UPS off)
Bypass voltage out of tolerance			Every 2 seconds
Bypass frequency unstable		FU	Every 2 seconds
Error EEPROM		EE	Every 2 seconds
Battery replacement required		bt	Every 2 seconds

#### 4.8. Error codes

Error	Code	Icon	Error	Code	Icon
BUS start error	01	X	Battery voltage too high	27	
BUS start error	02	X	Battery voltage too low	28	
BUS voltage low	03	X	Charging system shorted	2A	X
Inverter start error	11	X	Temperature too high	41	X
Inverter voltage high	12	X	Overload	43	
Inverter voltage low	13	X	Damage to the charging system	45	X
Inverter output short circuit	14		Input current too high	49	X

## 5. UPS operation

### 5.1. UPS turning on

To turn on the UPS, press and hold the ON/Mute button on the UPS display for 2 seconds.

Attention! For maximum autonomy, charge the batteries for at least 10 hours after first use. Maximum battery capacity is reached after two complete discharge/charge cycles.

### 5.2. UPS turning off

To turn off the UPS, press and hold the OFF/ENTER button on the UPS display for 2 seconds. Depending on the setting of parameter 06 of the settings menu (see section 4.5.) - Bypass availability, the UPS will disconnect the output or switch to Electronic Bypass mode.

To completely shut down the UPS, disconnect the power cord.

### 5.3. Battery test

To activate the test function in the UPS, press and hold the ON/MUTE key for 3 seconds when the UPS is operating in normal, economic or converter mode. The UPS will perform a self-test and then return to the previous operating state by itself.

### 5.4. Mutes the audible alarm

When the UPS is operating on battery, beeps are emitted. To mute the UPS, press and hold the ON/MUTE key for 3 seconds.

### 5.5. Software installation

To take full advantage of the UPS, install the supplied ViewPower communication software.

During the installation, follow the instructions on the computer screen.

After the installation process is complete, restart your computer. Restarting the computer will automatically start ViewPower, which is indicated by the appearance of the ViewPower icon in the Windows system tray.

## 6. UPS working environment and operation

### 6.1. Working conditions

To ensure proper working conditions for the uninterruptible power supply system, the room where the power supply is located must be clean, dust-free.

From time to time (at least every 6 months or more often depending on the degree of dirt), clean the ventilation holes on the power supply to ensure free air flow.

To extend battery life, the ambient temperature should be between 15-25°C.

### 6.2. The storage conditions

If the UPS is not in use and is intended to be stored or stored, it is necessary to recharge the batteries periodically to avoid damaging the batteries. Depending on the storage temperature, connect the power supply to charge the battery at least every 6 months. Typically, the batteries are charged within 4 hours to 90% capacity, but it is recommended to leave the power supply turned on for 24-48 hours to fully charge the batteries, which will extend their life.

---

*Temp. storage up to 20°C - charging every 6 months.*

*Temp. storage up to 30°C - charging every 3 months.*

*Temp. storage up to 40°C - charging every 1 month.*

---

### 6.3. Battery replacement

If the operating time of the UPS is less than half of the nominal with good batteries, or if the UPS reports a battery alarm, the batteries should be replaced immediately.

Attention! The UPS is equipped with internal batteries that can be replaced during operation without switching off the UPS and connected loads (hot-swap function).

---

*Although battery replacement is possible in Hot Swap mode, it is not recommended to replace the batteries while the UPS and receivers are operating. A possible power failure may result in loss of data or damage to receivers.*

---

It is safe for the user to replace the battery according to the following recommendations. Only use batteries with the same capacity, voltage and dimensions as the original.

---

*After disconnecting the battery, the receivers are not protected against power failures.*

---

---

*The batteries must not be replaced while the UPS is operating in battery mode!*

---

**Step 1**

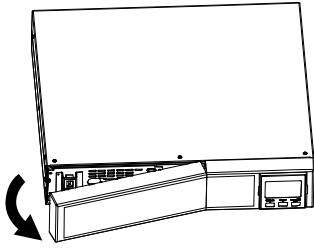

Remove the front panel.

**Step 2**

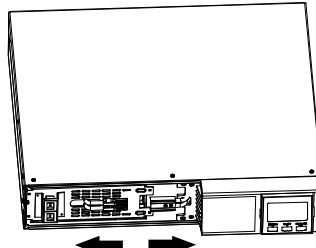

Disconnect the battery plugs.

**Step 3**

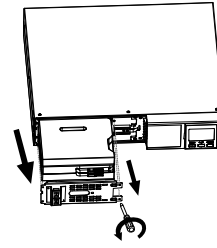

Remove the two mounting screws and pull out the battery pack.

**Step 4**

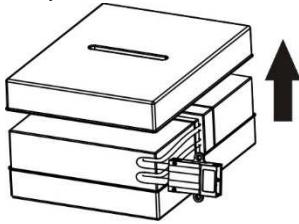

Remove the top cover from the battery pack and replace the batteries.

**Step 5**

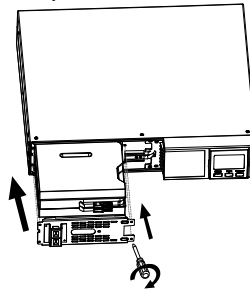

Reinstall the replaced battery pack and tighten the retaining screws.

**Step 6**

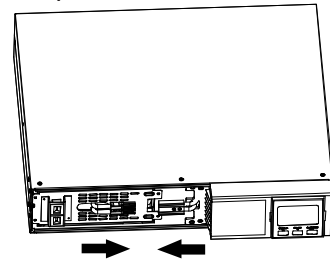

Connect the battery plugs.

**Step 7**

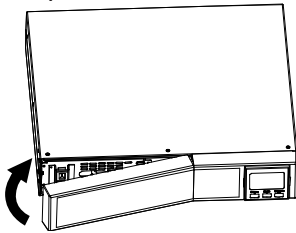

Install the front panel.



**CP Automation**  
Keeping industry  
in motion