



CP Automation
Keeping industry
in motion

Uninterruptible Power Supply UPS

Cover CORE 6 -10 kVA

User manual

Table of Contents

1.	Safety rules.....	1
2.	Transport, unpacking the UPS	3
2.1.	Horizontal assembly in the Rack 19 " cabinet	3
2.2.	Vertical mounting (tower)	4
3.	Appearance and connection	5
3.1.	Rear panel of the UPS and battery module.....	5
3.2.	Connecting external batteries	6
3.3.	Connecting the power supply and receivers	7
3.4.	Connection of remote EPO switch	7
3.5.	Control connector of the external EMBS service bypass	7
3.6.	Connection of communication options	8
4.	LCD display operation	9
4.1.	Function keys.....	9
4.2.	LED indicators	10
4.3.	LCD display.....	11
4.4.	Alarm signals.....	12
4.5.	LCD display letter abbreviations.....	12
4.6.	UPS settings menu	13
4.7.	Description of the UPS operation modes	15
4.8.	UPS warnings and audible alarms	17
4.9.	Warning codes	17
4.10.	Fault Codes - Active in Fault Mode (Fault LED active).....	18
5.	UPS operation	19
5.1.	Turn on the UPS from the mains	19
5.2.	UPS shutdown.....	19
5.3.	Turn on the UPS from the battery	19
5.4.	Transferring the UPS to the Maintenance Bypass mode	20
5.5.	Transferring the UPS from Maintenance Bypass mode to normal operation	20
5.6.	Battery test	20
5.7.	Mute the audible alarm.....	20
5.8.	Installing the software	20
5.9.	Working conditions.....	21
5.10.	The storage conditions	21
5.11.	Battery change.....	21

1. Safety rules

This manual provides information on the safe use of the UPS. Before unpacking and installing the UPS, read its contents and follow its instructions.

	FULFILLED STANDARDS - EXECUTION
EN 62040-3	Uninterruptible Power Systems (UPS): Methods for determining the characteristics and test requirements.

	FULFILLED STANDARDS - ELECTROMAGNETIC COMPATIBILITY
EN 62040-2 :2006 C3	Unsupported Power Systems (UPS): Electromagnetic Compatibility.
EN 61000-2-2 :2002	Electromagnetic Compatibility (EMC): Environment. Compatibility levels for conducted low-frequency disorders and signaling in public low-voltage power supply systems.
EN 61000-4-2 :2009	Electromagnetic Compatibility (EMC): Testing and measurement methods - electrostatic discharge immunity test.
EN 61000-4-3 :2006 +A1 :2008 +A2 :2010	Electromagnetic Compatibility (EMC): Test and Measurement Methods - Radio Frequency Electromagnetic Field Immunity Test.
EN 61000-4-4 :2004 +A1 :2010	Electromagnetic Compatibility (EMC): Test and Measurement Methods - Test of immunity to a series of fast electrical transients.
EN 61000-4-5 :2006	Electromagnetic Compatibility (EMC): Testing and Measurement Methods - Surge Immunity Test.
EN 61000-4-6 :2009	Electromagnetic compatibility (EMC): Test and measurement methods - Immunity to conducted disturbances, induced by radio frequency fields.
EN 61000-4-8 :2010	Electromagnetic Compatibility (EMC): Testing and measurement methods - Testing resistance to magnetic field at the frequency of the power grid.
The device complies with the Directive 2004/108 / EC (EMC).	

	FULFILLED STANDARDS - SAFETY
EN 62040-1 :2008	Uninterruptible Power Systems (UPS): General requirements and requirements for UPS safety.
EN 60950-1:2006 IEC 60417	Information technology devices. Security. Symbols used on devices.
The device complies with the 2006/95 / EC (LVD) directive.	

- Keep these operating instructions! The manual contains important instructions on the use of the UPS that should be followed during installation and use of the UPS device and batteries.
- Condensation may occur if the power supply is cold and is brought into a warm place. Therefore, you should wait at least 2 hours until it starts up.
- To reduce the risk of electric shock, the UPS should be installed in a pollution-free room with adequate temperature and humidity. The ambient temperature must not exceed 40 ° C.
- Do not install the power supply in a place exposed to direct sunlight or other heat sources.
- Do not connect devices that can overload the UPS output, e.g. laser printers, electric heaters, etc.
- Cables should be connected and arranged in such a way that no one can accidentally step on or disconnect them.
- The UPS must be connected to the electrical system with an efficient protective earth (GND).
- Do not block the ventilation openings on the UPS. Make sure the vents are exposed and there is a minimum of 25cm free space for free ventilation.
- The UPS power circuit should be protected with an appropriate overcurrent circuit breaker.
- The UPS has its own battery power source, so there may be voltage on the output strip, even though the UPS is not connected to the mains.
- Battery handling should be performed by trained personnel who are knowledgeable about battery operation and take appropriate precautions during its use.
- If it is necessary to replace the battery, use batteries of the same number and parameters, i.e. rated voltage, capacity and dimensions.

ATTENTION! Do not throw batteries into fire. The battery may explode.

ATTENTION! Do not open or mutilate the battery.

Released electrolyte is harmful to the skin and eyes and may be toxic.

- The battery can present a risk of electric shock. The following precautions should be taken when working with batteries:
 - Remove watches, rings and other metal objects from your hand.
 - Use tools with insulated handles.
 - Wear rubber gloves and boots.
 - Do not lay tools or metal parts on top of the battery.
 - Disconnect the battery charging source before connecting or disconnecting the battery terminals.
- Check that the battery is not inadvertently grounded. If present, remove the source of the ground fault. Contact with any part of a grounded battery can result in electric shock.

2. Transport, unpacking the UPS

Check carefully whether the carton and the contents are not damaged. If any damage is found, immediately inform the shipping company and the power supply distributor.
Do not throw away the UPS packaging.

1. If no damage is found, carefully open the carton.
2. Unpack all protective elements (sponges, fillers).
3. Gently remove the UPS from the protective film and place it on a clean, flat and stable surface.

To prevent mechanical damage, shock and impact, only transport the UPS in its original packaging.

All models of the CORE 6K and 10K power supplies are suitable for both horizontal and vertical mounting.

2.1. Horizontal assembly in the Rack 19 " cabinet

The CORE series power supply can be mounted in a Rack 19 " housing. The following space is required for installation:

- for a UPS of 2U height and depth greater than 60 cm,
- for a 3U high battery module and depth greater than 60 cm.

Each element requires the use of brackets for mounting in a rack.

You can also use the so-called rails. Rail Kit 19 "- available as optional equipment.

For proper installation:

Step 1

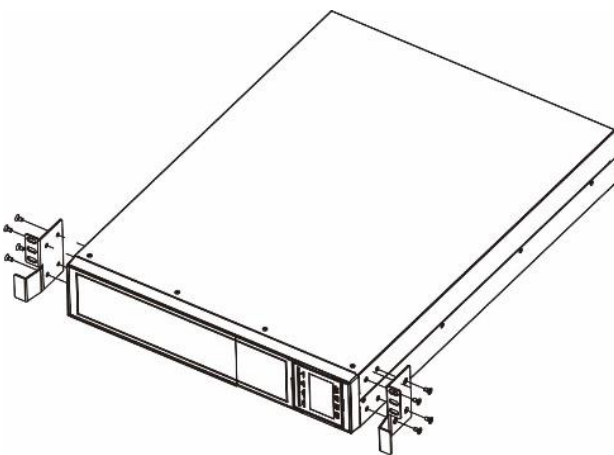

Step 2

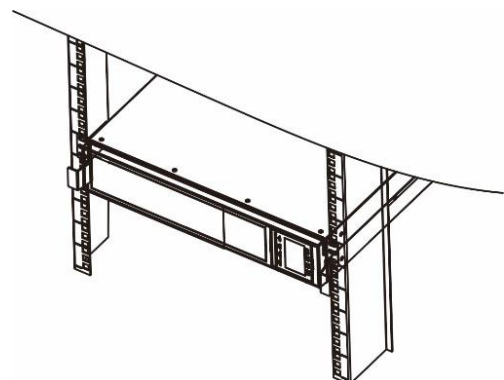

2.2. Vertical mounting (tower)

To install the power supply in the Tower position, you need to use special stands that secure the power supply and enable its stable placement in a vertical position. The set of stands includes short and long connecting elements, depending on the width of the UPS set.

In order to place the power supply correctly:

Step 1

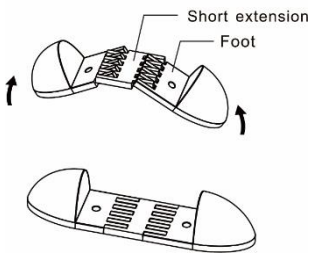

Step 2

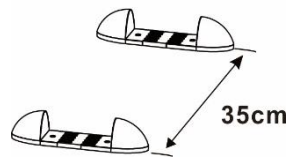

Step 3

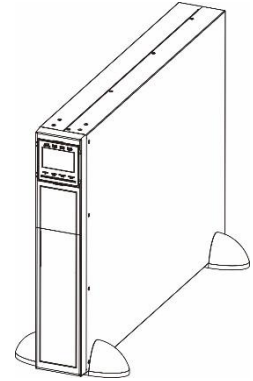

In order to properly place the power supply and the battery module (5U set):

Step 1

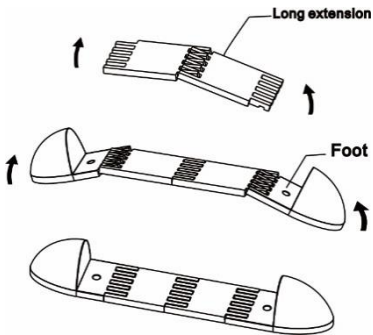

Step 2

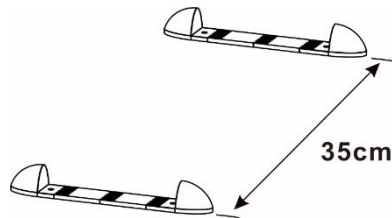

Step 3

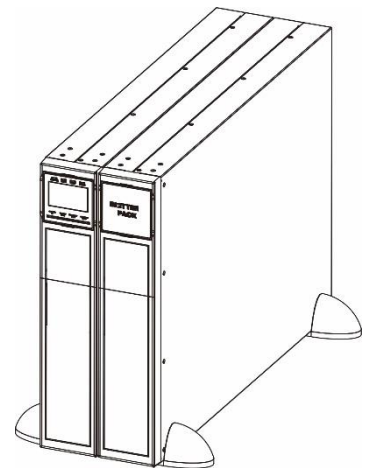

3. Appearance and connection

3.1. Rear panel of the UPS and battery module

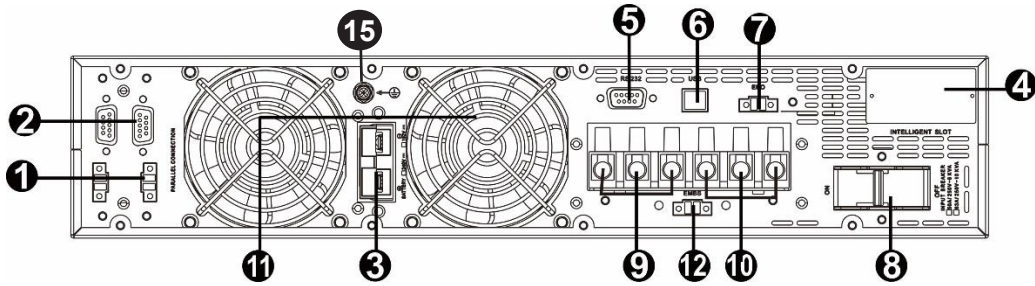

Fig. 1 COVER CORE 6-10K power supply

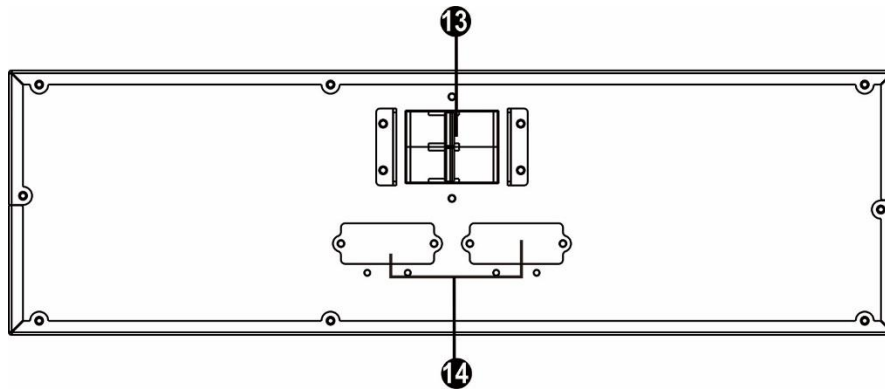

Fig. 2 EBM 6/10 - 3U battery module.

1. Current connectors (only for the parallel operation version) - option.
2. Parallel operation connectors (only for the parallel operation version) - option.
3. External battery connector.
4. INTELLIGENT SLOT communication card slot (LAN card, AS400, RS485).
5. RS-232 communication port.
6. USB communication port.
7. Remote Emergency Power Off (EPO) connector.
8. UPS power circuit fuse.
9. Output terminal.
10. Input terminal (UPS power).
11. Fans.
12. Control connector of the external EMBS service bypass.
13. Battery circuit breaker.
14. Extra battery connector.
15. Ground connection.

3.2. Connecting external batteries

Make sure there is a battery circuit breaker between the UPS and the battery module. Before connecting the battery module and the UPS, the circuit breaker must be turned OFF.

Make sure the number of batteries in the battery module is appropriate for the amount for which the UPS has been configured. The standard quantity of 12 V batteries for the UPS is 20.

Connect one end of the battery cable to the appropriate socket on the rear panel of the UPS, the other end to the socket located on the battery module. In the case of more battery modules, the remaining connections are made between the supplied battery modules as in the figure below.

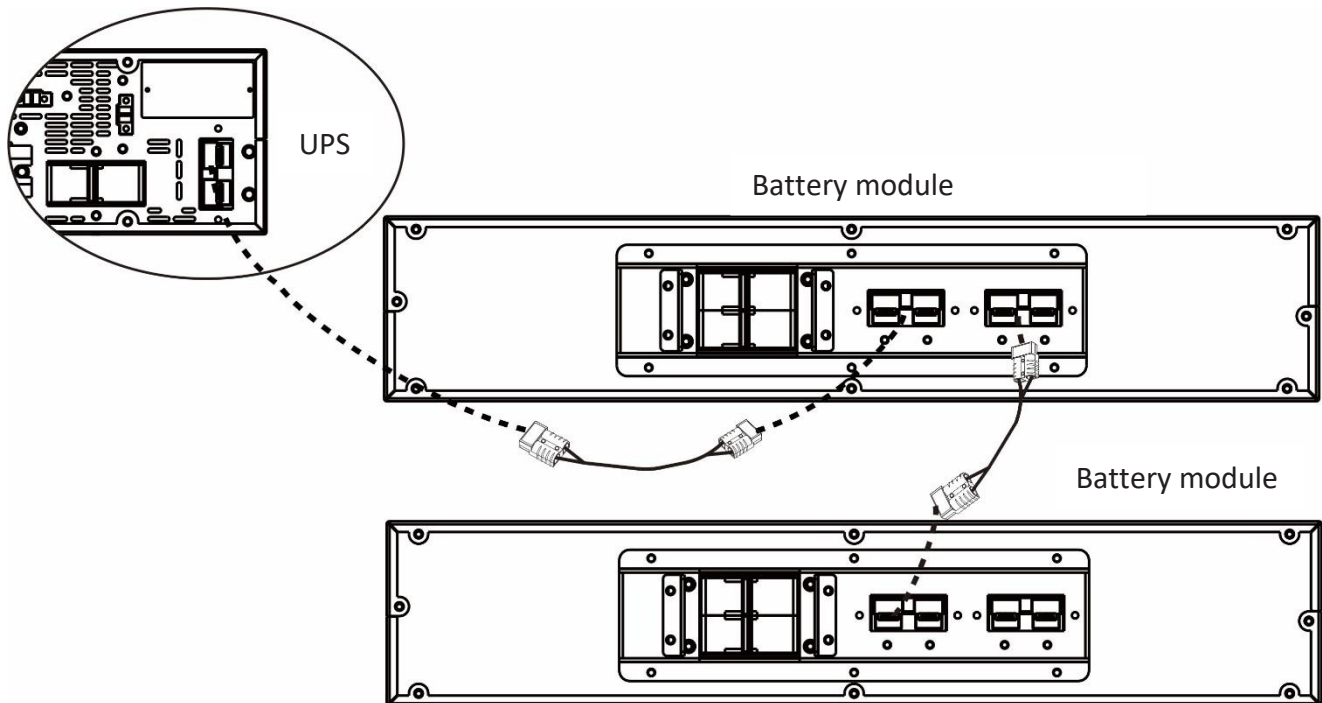

If it is necessary to extend the autonomy time, the power supply has the option of connecting a battery with a much larger capacity, thanks to the fact that it is equipped with an adjustable Charger with a capacity of 4A. Changes to the settings of the maximum battery charging current are made by an authorized service of the PSU manufacturer.

When using larger capacity external batteries, placed on racks or in cabinets, special attention should be paid to the installation of an additional disconnecter in the battery circuit, the correct polarity of the cables connected to the UPS battery and the number of batteries used.

Incorrect connection of the "+" and "-" wires or connection of the wrong number of batteries may cause permanent damage to the UPS and the batteries.

3.3. Connecting the power supply and receivers

The CORE 6K and 10K UPS is designed for permanent connection through the terminal block located on the back of the UPS, as shown in the figure below.

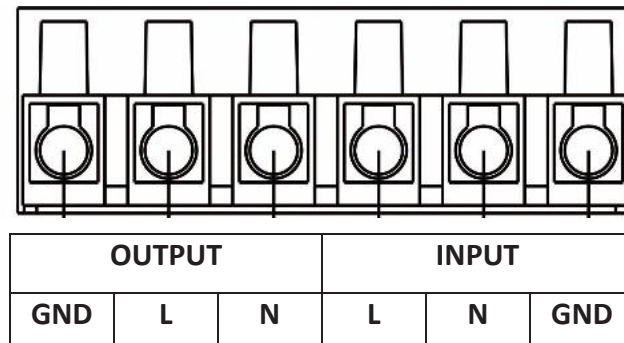

*UPS adapted for installation in a single-phase, three-wire installation,
TN with a grounded neutral.*

The UPS should be connected to a separate electrical installation, made in accordance with the manufacturer's Installation Recommendations. Installation should be carried out in accordance with the regulations and rules in force in a given country. The UPS power supply circuit should be protected with a circuit breaker or a fuse with the trip current value required in the recommendations. It is not recommended to use residual current devices in the UPS input.

Cables should be connected and arranged in such a way that no one can accidentally disconnect them.

3.4. Connection of remote EPO switch

The UPS is equipped with an EPO port for connecting a remote emergency stop switch. / REPO (Remote Emergency Power Off). By default, the EPO port is configured as NC (normally closed), activation of EPO takes place by breaking the connection between Pin 1 and Pin 2 (removal of the jumper).

It is possible to change the EPO configuration to NO (normally open) - contact an authorized service center. Changing the configuration to NO causes the need to remove the jumper between Pin 1 and Pin 2.

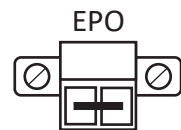

3.5. Control connector of the external EMBS service bypass

The EMBS connector is used to connect the auxiliary contacts of the External Maintenance Bypass switch to ensure that the UPS inverter is shut down when the External Bypass is turned on.

The EMBS connector is NO (normally open) type.

A short circuit (between Pin 1 and Pin 2) causes the inverter to shut down.

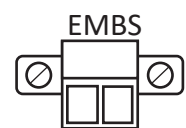

3.6. Connection of communication options

The UPS has three communication ports:

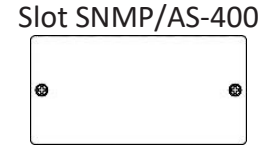

To enable automatic management and monitoring of the UPS, connect the USB cable supplied with the device, on one side to the USB socket on the UPS and on the other side to the USB socket on the computer.

The software provided with the UPS allows you to automate the processes of switching on and off the receivers connected to the UPS depending on the events that occur on the UPS (e.g. power failure, low battery level). The software also allows for ongoing monitoring and logging of UPS event history.

RS232 and USB ports cannot be used simultaneously.

The UPS also has an INTELLIGENT SLOT for additional cards, allowing for the use of communication options. Additionally, you can connect to the device:

- LAN card - allowing communication via LAN / WAN with the use of e.g. protocols: WWW, SNMP, Modbus TCP,
- AS-400 relay contact card for communication with external supervision systems, e.g. BMS, alarm control units,
- Modbus card with RS485 port, allowing communication using the Modbus RTU protocol, e.g. with BMS systems.

4. LCD display operation

4.1. Function keys

There are 4 buttons on the control panel of the UPS which are used to operate the UPS and the LCD.

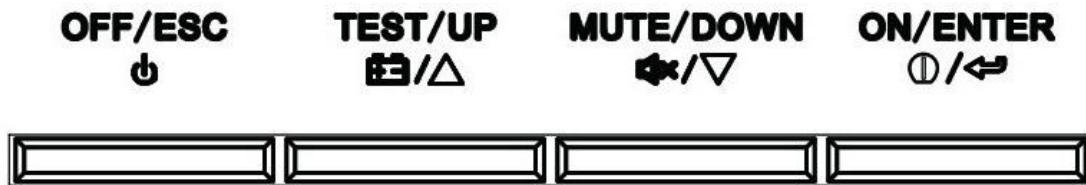

Button	Function
ON/ENTER	<ul style="list-style-type: none"> Turn on the UPS: Press and hold for more than 0.5 seconds to turn on the UPS. ENTER: Press the key to confirm the selection in the UPS menu.
OFF/ESC	<ul style="list-style-type: none"> UPS shutdown: Press and hold for more than 0.5 seconds to turn off the UPS. ESC: Press the key to return to the previous menu page.
TEST/UP	<ul style="list-style-type: none"> Battery test: Press and hold for more than 0.5 seconds during normal operation of the UPS to activate the test. Up arrow: Key to scroll up to the previous line in the UPS setup menu.
MUTE/DOWN	<ul style="list-style-type: none"> Mute the alarm: When the UPS is on battery, press and hold for more than 0.5 seconds to silence or enable the buzzer. Alarm silencing is not possible in the event of an alarm condition. Down arrow: Key for scrolling down to the next line in the UPS setup menu.
TEST/UP + MUTE/DOWN	<ul style="list-style-type: none"> Menu entry or exit: Press both buttons simultaneously for more than 1 second to enter or exit the UPS settings menu.

4.2. LED indicators

The UPS is equipped with an intuitive LCD panel and four LED indicators for easy reading of the UPS status UPS.

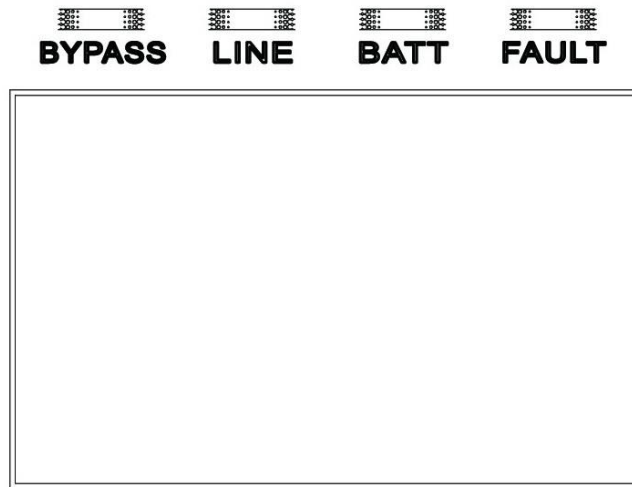



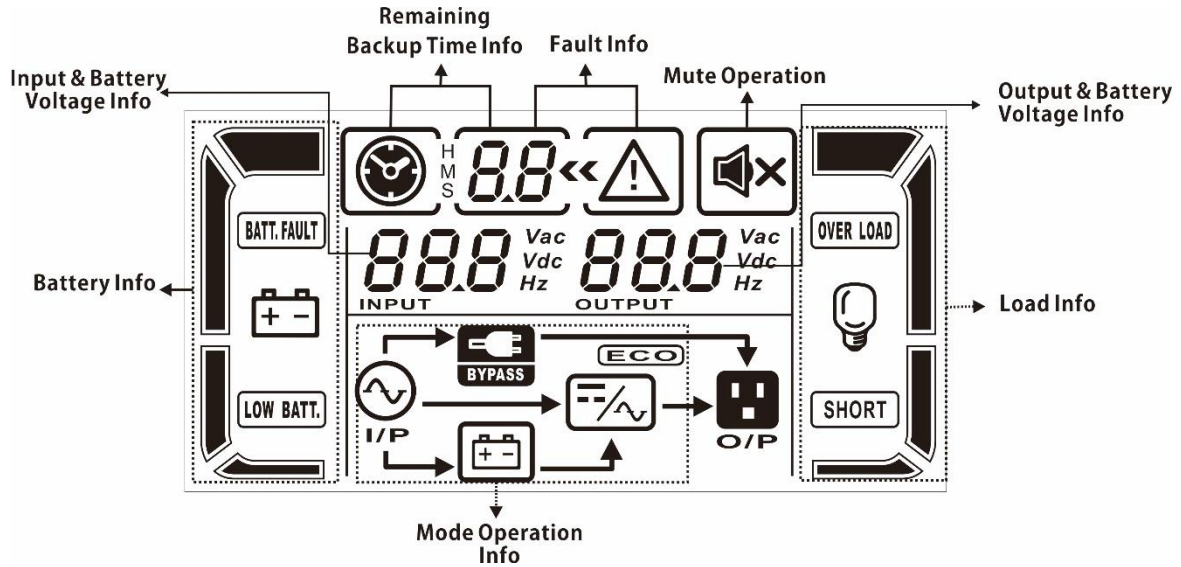

The status of the LEDs determines the current operating status of the power supply and is described in the table below:

Mode \ LED	Bypass	Line	Battery	Fault
UPS start	●	●	●	●
No output	○	○	○	○
Bypass mode	●	○	○	○
Normal mode	○	●	○	○
Battery mode	○	○	●	○
Converter mode	○	●	○	○
Battery test	●	●	●	○
ECO mode	●	●	○	○
Error Mode	○	○	○	●

4.3. LCD display

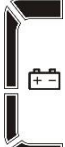

LCD	Function
Information about the time of autonomy	
	Displays the estimated autonomy of the UPS H: hours, M: minutes, S: seconds
Configuration and error information	
	Indicates that an error or warning occurs.
	Displays an error or warning code.
Output information	
	Displays the voltage or frequency parameters and the battery voltage. Vac: output voltage, Hz: output frequency, Vdc: battery voltage
Load information	
	Indicates the load level of 0-24%, 25-49%, 50-74%, and 75-100%.
	Indicates an overload condition.
	Indicates a short circuit condition at the device output.
Information about the operating mode	
	Indicates that the UPS is connected to the 230V mains.
	Indicates that the UPS is running on battery.
	Indicates the UPS is in Bypass mode.
	Indicates that the ECO mode is on.
	Indicates that the UPS inverter is running.
	Indicates that the output voltage is present.
	Indicates the sound on the UPS is muted.

Battery information	
	Indicates a charge level of 0-24%, 25-49%, 50-74%, and 75-100%.
	Indicates a defective battery condition.
	Indicates a low battery voltage condition.
Information about power supply parameters and battery voltage	
	Displays input voltage and frequency parameters and battery voltage. Vac: 230V mains voltage, Vdc: battery voltage, Hz: mains frequency

4.4. Alarm signals

Battery mode	Beep every 4 seconds.
Bypass mode	Beep every 2 minutes.
Overload	Beep 2x / second.
Error	Continuous tone.

4.5. LCD display letter abbreviations

Short	Wskazanie wyświetlacza	Meaning (eng.)
ENA	<i>ENA</i>	Enabled
DIS	<i>DIS</i>	Disabled
ATO	<i>ATO</i>	Auto
BAT	<i>BAT</i>	Battery
NCF	<i>NCF</i>	Normal mode
CF	<i>CF</i>	Converter mode
SUB	<i>SUB</i>	Subtract
ADD	<i>ADD</i>	Add
ON	<i>ON</i>	Turn ON
OFF	<i>OFF</i>	Turn OFF
FBD	<i>Fbd</i>	Not allowed
OPN	<i>OPN</i>	Allowed
RES	<i>RES</i>	Reserved
OP.V	<i>OPV</i>	Output voltage
PAR	<i>PAR</i>	Parallel mode

4.6. UPS settings menu

To enter the configuration menu, press the Test / Up + MUTE / Down buttons simultaneously for more than 1 second. View of the configuration menu and description of the possible settings below.

To access all settings, the UPS should be in Stand-by mode (no voltage at the UPS output) or Bypass mode (parameters 15 and 16 are available while the inverter is running).

Parameter 1





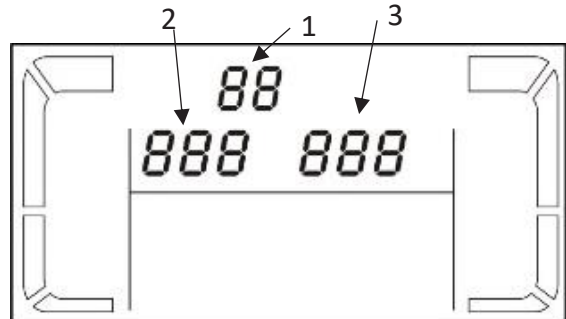

Indicates the number assigned to a specific parameter as described below, e.g. 01 - output voltage.





Parameter 2 and 3

Indicates a value specific for a given parameter, e.g. 230 - the value of the output voltage.

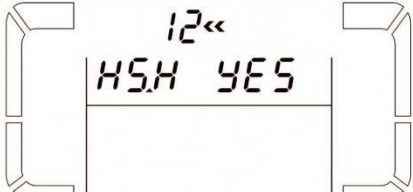

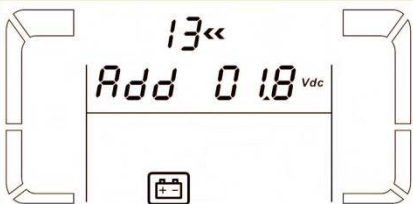
Display state	Settings
01 - Setting the output voltage value	
	208: Indicates 208Vac output voltage 220: Indicates 220Vac output voltage 230: indicates 230Vac output voltage (default) 240: Indicates 240Vac output voltage
02 – The output frequency	
60 Hz, CVCF mode 	Parameter 2: The output frequency Allows you to select the frequency: 50Hz: The output frequency is 50Hz 60Hz: The output frequency is 60Hz ATO: autosensing. The UPS automatically detects the frequency of the utility voltage. Parameter 3: UPS operating mode CF: UPS works as a frequency converter. The output frequency value should be set to 50 or 60 Hz. NCF: The UPS works in normal mode, within the tolerance of the input frequency, the UPS synchronizes to the mains frequency. Exceeding the permissible frequency tolerance causes the UPS to switch to battery operation.
50 Hz, Normal mode 	
ATO 	
03 - Voltage tolerance range for Bypass	
	Parameter 2: Lower Voltage Tolerance Range for Bypass. The value is adjustable from 110-209V (default 110V). Parameter 3: High Voltage Tolerance Range for Bypass. The value is adjustable from 231-276V (default 264V).

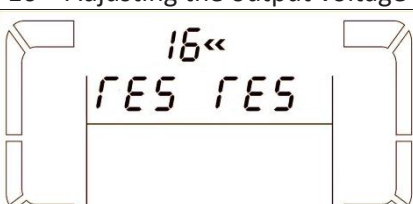
04 – Frequency tolerance range for Bypass	
	<p>Parameter 2: Lower Voltage Tolerance Range for Bypass. 50Hz: possible settings 46-49Hz (default 46Hz) 60Hz: possible settings 56-59Hz (default 56Hz)</p> <p>Parameter 3: High voltage tolerances for Bypass. 50Hz: possible settings 51-54Hz (default 54Hz) 60Hz: possible settings 61-64Hz (default 64Hz)</p>
05 – ECO mode	
	<p>Set the availability of economy mode ENA: ECO function available DIS: ECO function unavailable (default)</p>
06 – Voltage tolerance range in ECO mode	
	<p>Parameter 2: Setting the lower voltage tolerance for ECO mode. Possible settings -5% ÷ -10% of the nominal value of the input voltage.</p> <p>Parameter 3: Setting the upper voltage tolerance for ECO mode. Possible settings + 5% ÷ + 10% of the nominal value of the input voltage.</p>
07 – Frequency tolerance range in ECO mode	
	<p>Parameter 2: Low frequency tolerance setting for ECO mode. Possible settings: 50Hz: 46Hz ÷ 48Hz (default 48Hz) 60Hz: 56Hz ÷ 58Hz (default 58Hz)</p> <p>Parameter 3: Setting the upper frequency tolerance for ECO mode. Possible settings: 50Hz: 52Hz ÷ 54Hz (default 52Hz) 60Hz: 62Hz ÷ 64Hz (default 62Hz)</p>
08 – Bypass mode settings	
	<p>Parameter 2: OPN: Bypass allowed. UPS can work in Bypass mode depending on available / unavailable setting. FBD: Bypass not allowed under any circumstances.</p> <p>Parameter 3: EAW: Bypass available. DIS: Bypass unavailable - it means that the bypass can not be forced manually from the LCD panel. Automatic bypass available.</p>
09 – Battery autonomy limitation	
	<p>Parameter 2: Setting the maximum battery life 0 - 999 minutes for critical (non-programmable) sockets.</p> <p>DIS: Restriction lock. Autonomy depending on battery capacity. (default) Attention! Setting the value to "0" - means an autonomy of 10 seconds.</p>
10, 11 – Reserve (No functions available)	
12 – Hot Standby feature available	
	<p>Enables or disables the Hot Standby HS.H function YES: Function available. It enables the UPS to restart after the supply voltage is restored, even without the batteries connected. NO: Function disabled. The UPS is operating normally and will not turn on without the batteries connected.</p>

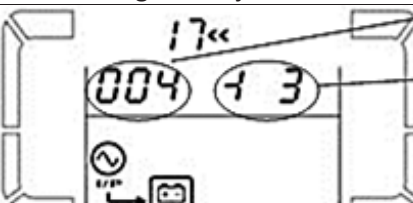



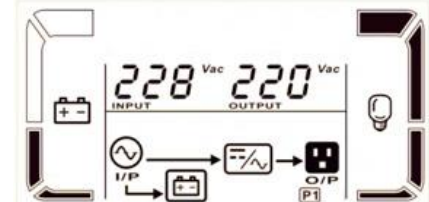
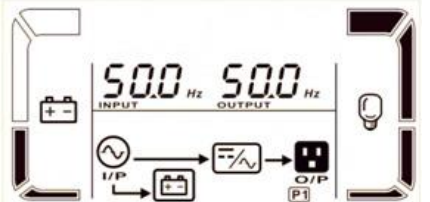



13 – Battery voltage regulation	
	Parameter 2: Choose “Add” or “Sub” to make battery voltage Up / Down adjustment. Parameter 3: Voltage regulation range 0 - 5.7V (default 0V).
14 – Charger voltage adjustment	
	Parameter 2: Choose “Add” or “Sub” to make the Charger Voltage Up / Down adjustment. Parameter 3: Voltage regulation range 0 - 9.9V (default 0V). The batteries must be disconnected before calibrating.
15 – Inverter voltage regulation	
	Parameter 2: Choose “Add” or “Sub” to make the Charger Voltage Up / Down adjustment. Parameter 3: voltage adjustment range 0 - 6.4V (default 0V).
16 – Adjusting the output voltage	
	If the output voltage cannot be identified (below 50V) in the menu it is not possible to make changes.
	Parameter 2: Indicates the OP.V output voltage Parameter 3: Indicates the UPS output voltage measured inside the UPS. Using the arrow keys, calibrate the value of the output voltage to the actual value indicated by the meter. The result of the calibration is obtained by confirming the change with the Enter key. Voltage regulation range +/- 9V.
17 – Setting and adjustment of the charging current	
	Parameter 2: Charging current 001-004 means 1.2, 3, 4 A respectively Parameter 3: Correction of the charging current "+" or "-" by 0.1x the set value. For example, "+" "3" means the current is increased by +0.3A

4.7. Description of the UPS operation modes

Operation mode	Description	LCD status
Normal mode (OnLine)	In all online UPSs, fans are working all the time. The only difference is with speed rotation – it depends on the temperature and the load, but are working non stop.	 

<p>ECO mode</p>	<p>Economy mode If the supply voltage is within tolerance, the supply voltage is supplied directly to the UPS output. The inverter is in Stand-by mode, which increases efficiency and reduces operating costs.</p>
<p>CVCF converter mode</p>	<p>If the frequency of the supply voltage is within the range of 46 ÷ 64Hz, it is possible to set a fixed value of the frequency of the output voltage 50 or 60Hz. In this mode, the batteries are also charged.</p>
<p>Battery operation mode</p>	<p>In the event of a power failure or when the supply voltage is beyond the tolerance allowing the output voltage to be kept within the required tolerance, the UPS switches to battery operation. The beep sounds every 4 seconds.</p>
<p>Bypass mode</p>	<p>If the mains voltage is within the acceptable tolerance limits, but an overload or any other event occurs, the UPS will switch to Bypass mode. The acoustic signal is issued every 2 minutes.</p>
<p>Battery test</p>	<p>Pressing the "Test" key for half a second while the UPS is in normal mode or in frequency converter mode, will force the battery test.</p>
<p>Alarm</p>	<p>In emergency mode, the UPS indicates the error code and the icons associated with the event.</p>



4.8. UPS warnings and audible alarms

Warning	Icon (blinks)	Alarm
Low battery voltage		Beeps every second
Overload		Beep 2x / second
Battery non connected		Beeps every second
Overload		Beeps every second
Power fuse damaged		Beeps every second
EPO input active		Beeps every second
Fan error / Overheating		Beeps every second
Charger damaged		Beeps every second
3 times overload within 30 min.		Beeps every second

4.9. Warning codes

Code	Warning	Code	Ostrzeżenie
01	Batteries not connected	21	EC supply differences - parallel operation
07	Battery overcharging	22	Differences on Bypass - Parallel Work
08	Batteries are discharged	33	Bypass blocked - 3 overloads in 30 min.
09	Overload	3A	EBMS active (External Bypass connector)
0A	Fan error	3D	Unstable Bypass parameters
0B	EPO active	3E	No bootloader
0D	Overheated	42	Transformer overheating
0E	Charger failure	44	Loss of redundancy - parallel operation
10	L1 WE fuse blows	45	Overload - parallel operation

4.10. Fault Codes - Active in Fault Mode (Fault LED active)

Code	Icon	Fail
01	-	BUS start error
02	-	High BUS voltage
03	-	BUS low voltage
04	-	BUS voltage unbalance
11	-	Inverter start error
12	-	Inverter voltage is too high
13	-	Inverter voltage is too low
14		Short circuit on the inverter output
1A	-	Reverse power at the inverter output
21	-	Battery thyristor short circuit
24	-	Inverter relay shorted
2A	-	Charger short circuit
31	-	CAN communication error
41	-	Overheated
42	-	CPU communication error
43		Overload
60	-	Inverter current too high
6A	-	Battery startup error
6B	-	PFC damage
6C	-	BUS voltage ripple
6D	-	Inverter current measurement error
6E	-	Damage to the SPS 12 V power supply

5. UPS operation

5.1. Turn on the UPS from the mains

1. Turn the battery disconnect switch located on the rear panel of the battery module or near the battery cabinet for external batteries to the ON position.
2. Switch on the UPS power in the UPS switchboard. When power is applied, the LCD panel lights up and the fans start to run. A few seconds later, the UPS enters Bypass mode.

Turning on the UPS power will turn to Bypass mode. At that time, the receivers are supplied with voltage from the UPS input and are not protected against power outages. To start the UPS inverter, turn on the UPS - step 3.

3. To turn on the UPS, press and hold the ON button on the UPS display for more than 0.5 seconds. The UPS will confirm the start with an acoustic signal.
4. A few seconds later, the UPS turns on the inverter and starts normal operation.

In case the supply voltage is outside the tolerance, the UPS starts to work from the battery. When the battery is discharged, the power is turned off. The restoration of the power supply will automatically restart the UPS to normal operation.

Attention! In order to obtain the maximum autonomy, the batteries should be charged at least 10 hours after the first use. The maximum capacity of the battery is obtained after two full discharge / charge cycles.

5.2. UPS shutdown

1. Turn off the UPS inverter by pressing the OFF key for more than 0.5 seconds. The UPS will confirm shutdown with a single beep and switch to Bypass mode.

In the event that the UPS is operated on battery, the above procedure turns off the UPS and the voltage at the UPS output.

2. In Bypass mode, the output voltage is supplied directly from the mains. To completely shut down the UPS, turn off the loads connected to the UPS, and then disconnect the UPS power. Seconds later, the UPS turns off the LCD panel and stops the fans.
3. Turn the battery circuit breaker to the OFF position.

5.3. Turn on the UPS from the battery

1. Turn the battery disconnect switch located on the rear panel of the battery module or near the battery cabinet for external batteries to the ON position.
2. Press the ON key to turn the UPS into Stand-by mode. After turning on the display, press the ON key again for more than 0.5 seconds to turn on the inverter and apply voltage to the UPS output.
3. A few seconds later, the UPS enters Battery mode.

5.4. Transferring the UPS to the Maintenance Bypass mode

The following procedure is for a UPS equipped with an external Maintenance Bypass. Switching the UPS to the Maintenance Bypass mode means that the receivers are not protected against power failures.

1. Turn off the UPS inverter by pressing the OFF key for more than 0.5 seconds. The UPS will confirm shutdown with a single beep and switch to Bypass mode.
2. Switch the external Maintenance Bypass from UPS position to BYPASS position.
3. Disconnect the UPS from the power supply to completely shut down the UPS. Seconds later, the UPS turns off the LCD panel and stops the fans.
4. Turn the battery circuit breaker to the OFF position.

5.5. Transferring the UPS from Maintenance Bypass mode to normal operation

1. Turn the battery disconnect switch located on the rear panel of the battery module or near the battery cabinet for external batteries to the ON position.
 2. Switch on the UPS power in the UPS switchboard. When power is applied, the LCD panel lights up and the fans start to run. A few seconds later, the UPS enters Bypass mode.
-

Make sure the Bypass LED is on to go to the next step.

3. Switch the external Maintenance Bypass from BYPASS position to UPS position.
4. To turn on the power supply (start the inverter) press the ON button on the UPS display and hold it for more than 0.5 seconds. The UPS will confirm the start with an acoustic signal.
5. A few seconds later, the UPS turns on the inverter and starts normal operation.

5.6. Battery test

To activate the test function in the UPS, press the TEST button when the UPS is operating in normal, economic or converter mode. The UPS will run the test automatically and then go back to the previous working state.

The battery test can be performed periodically in the automatic mode after the appropriate configuration of the software connected to the UPS.

5.7. Mute the audible alarm

The UPS emits beeps while the UPS is operating on battery. To silence the UPS, press and hold the MUTE key for more than 0.5 seconds.

5.8. Installing the software

To take full advantage of the UPS, please install the provided ViewPower communication software. During the installation, follow the instructions on the computer screen. You must restart your computer after the installation process is complete. Restarting the computer will automatically launch ViewPower, as shown by the ViewPower icon in the Windows system tray.

Środowisko pracy i eksploatacja UPS

5.9. Working conditions

To ensure proper working conditions for the uninterruptible power supply system, the room with the power supply must be dry, clean and free of dust and dirt.

From time to time (at least every 6 months or more often depending on the degree of soiling), clean the ventilation openings on the power supply to ensure free air flow.

To extend the battery life, the ambient temperature should be between 15 and 25 ° C.

*It is not recommended to operate the UPS at temperatures outside the range of 0 ÷ 40 ° C
and with a humidity exceeding 95% (no condensation).*

5.10. The storage conditions

If the UPS is not in use and storage or storage is envisaged, the batteries must be recharged periodically to avoid damaging them. Depending on the storage temperature, the power supply should be connected at least every 6 months to charge the battery. Typically, the batteries are charged in 4 hours to 90% capacity, but it is recommended to leave the power supply on for 24-48 hours to fully charge the batteries, which will extend their life.

Temp. storage up to 20 ° C - charging every 6 months.

Temp. storage up to 30 ° C - charging every 3 months.

Temp. 40 ° C storage - charging every 1 month.

5.11. Battery change

If the operating time of the UPS is halved with the batteries working properly, or the UPS reports a battery alarm, the batteries should be replaced immediately.

After disconnecting the batteries, the receivers are not protected against power outages.

It is not recommended to replace the batteries while the UPS and receivers are operating.

It is not allowed to replace the batteries while the UPS is operating in battery mode!



CP Automation
Keeping industry
in motion