

 **ELTROPLAN-REVCON**

Operating instructions

**REVCON**

**200 kW**

**160 kW**

**135 kW**

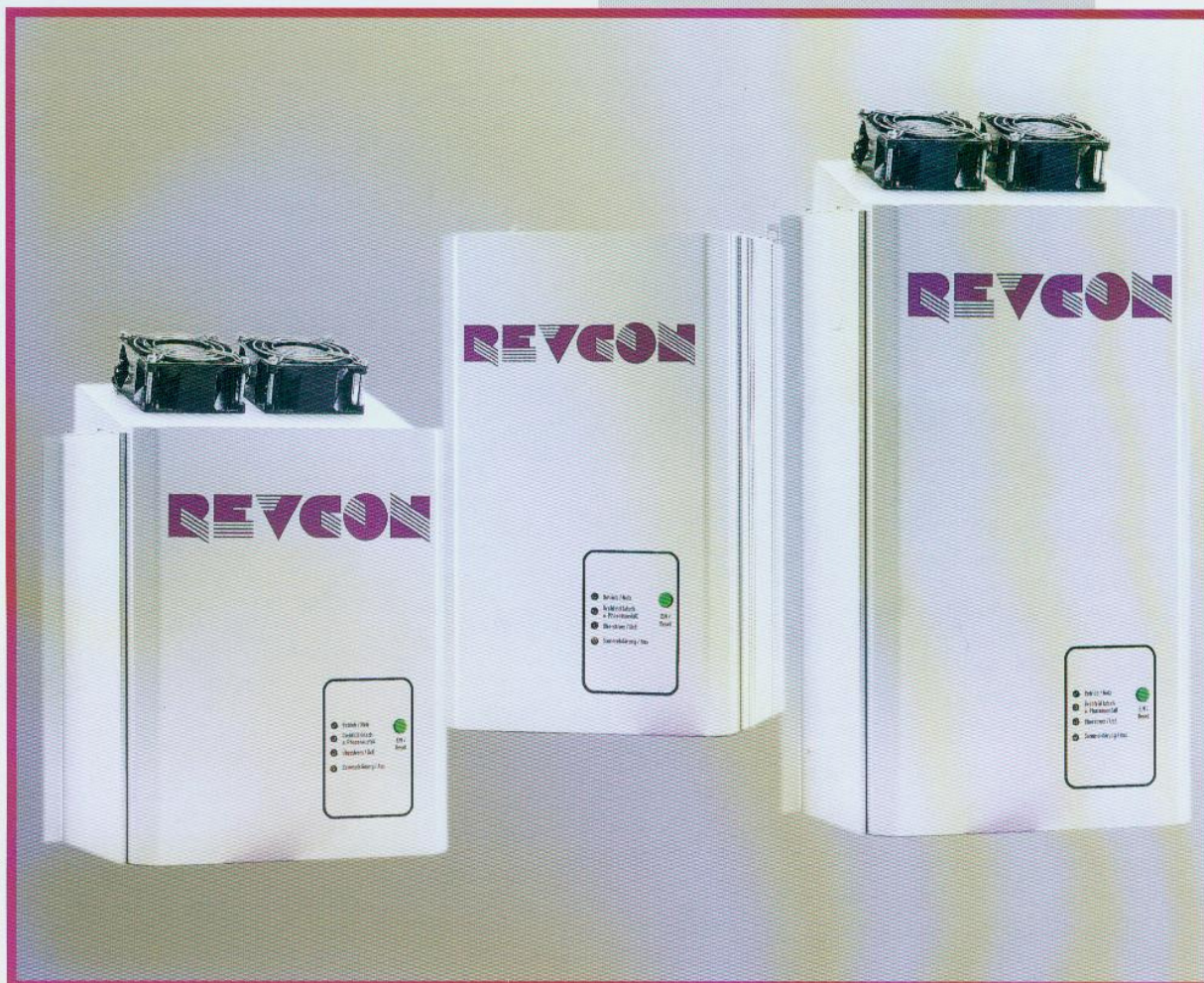

Power feedback unit

**REVCON<sup>®</sup> SVCS**

Power range 7 ... 33kW

Rated voltage 400V

**22 kW**

**13 kW**

**7 kW**



1	Preface and general information .....	3
1.1	About these Operating Instructions .....	3
1.1.1	Terminology used.....	3
1.1.2	Type determinant .....	4
1.2	Scope of delivery .....	4
1.3	Legal regulations.....	5
1.4	EC-Directives / Declaration of conformity.....	6
1.4.1	What is the purpose of EC-Directives?.....	6
1.4.2	What is the meaning of the CE-mark? .....	6
1.4.3	EC-Low-Voltage Directive .....	6
1.4.4	EC-Directive Machinery .....	8
2	Safety information .....	10
2.1	General safety information .....	11
2.2	Safety-responsible persons .....	15
2.3	Usage as directed .....	15
2.4	Layout of the safety information .....	16
2.5	Residual hazards .....	16
2.6	General instructions .....	17
3	Technical data .....	27
3.1	Characteristics.....	27
3.2	General data / application conditions.....	28
3.3	Rated data .....	29
3.3.1	Power feedback unit.....	29
3.3.2	Current load.....	30
3.3.4	Fuses and wire cross sections.....	34
3.3.4.1	Series fuses .....	34
3.3.4.2	Internal fuses.....	35
3.3.5	RFI-filter .....	36
3.3.6	SKS-module .....	36
4	Installation .....	37
4.1	Mechanical installation .....	37
4.1.1	Important hints .....	37
4.2	Dimensions .....	38
4.2.1	Power feedback unit.....	38
4.2.2	RFI-filters.....	41



## Contents

4.3	Electrical installation.....	43
4.3.1	Operator's safety.....	43
4.3.2	Protection of the power feedback unit.....	43
4.3.3	Mains types / Mains characteristics.....	44
4.3.4	Specifications of the used wires.....	44
4.4	Connection.....	45
4.4.1	Power connection.....	45
4.4.1.1	Wiring schematic.....	47
4.4.2	Fan supply.....	49
4.4.3	Control wires.....	49
4.4.4	Control functions.....	49
4.5	Application example.....	53
4.6	Installation of a power feedback unit in a CE-typical drive system.....	54
4.6.1	Installation.....	55
4.6.2	Connection of a RFI-filter.....	56
4.6.3	Design of an EMC-conformal cabinet.....	57
4.6.4	Remarks.....	58
4.6.5	Installation of control wires.....	59
5	Commissioning.....	60
5.1	First powering up.....	60
6	Configuration.....	61
7	Troubleshooting and fault elimination.....	64
7.1	LED-messages.....	65
8	Service.....	66
9	Appendix.....	67
9.1	Options.....	67
9.2	REVCON Product overview.....	69
9.3	Contact.....	70

# 1 Preface and general information

## 1.1 About these Operating Instructions

- These Operating Instructions help you to work properly on and with the power feedback units *REVCON*<sup>®</sup> SVCS. They contain safety information which must be observed and information which are necessary for an undisturbed operation of the units together with the exploitation of all the advantages of the system.
- All persons who work on and with the power feedback units *REVCON*<sup>®</sup> SVCS, must have the Operation instructions available and observe all relevant notes and instruction.
- The Operating Instructions must always be in a complete and perfectly readable state.

### 1.1.1 Terminology used

#### **Power feedback unit**

For „Power feedback unit *REVCON*<sup>®</sup> SVCS“ in the following the term „Power feedback unit“ is used.

#### **Controller**

For the frequency inverter which is used together with the power feedback unit in the following the term „Controller“ is used.

#### **Drive system**

For a drive system with power feedback units, controller and other components of the drive system in the following the term „Drive system“ is used.

### 1.1.2 Type determinator

SVCS 33 - XXX - 1 - 230 V AC

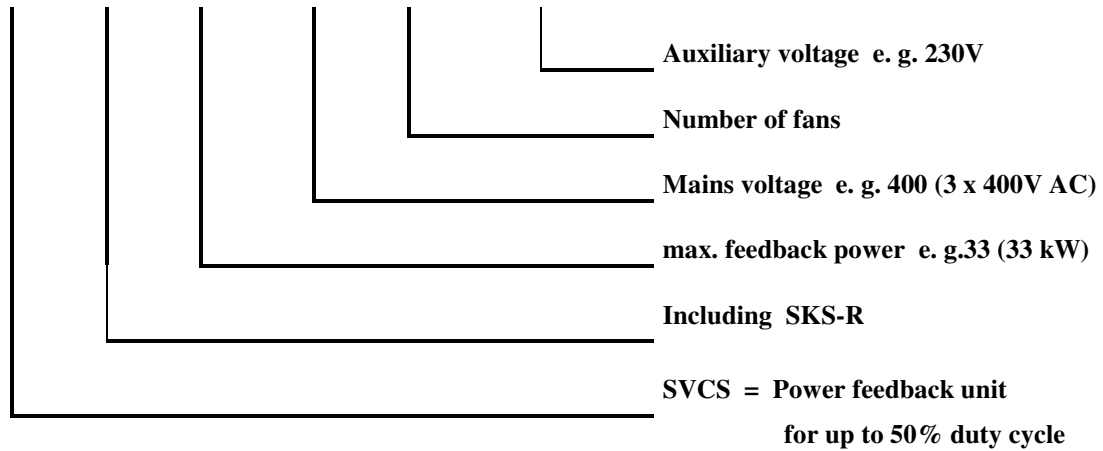

### 1.2 Scope of delivery

- 1 Power feedback unit *REVCON*<sup>®</sup>
- 1 Operating Instructions

After receipt of delivery, check immediately whether the scope of supply matches with the accompanying papers. We do not accept any liability for deficiencies claimed subsequently.

Claim

- visible transport damage immediately to the forwarder .
- visible deficiencies/incompleteness immediately to ELTROPLAN *REVCON*.

### 1.3 Legal regulations

<b>Labelling</b>	<b>Nameplate</b>	<b>CE-mark</b>	<b>Manufacturer</b>
	Power feedback units <i>REVCON</i> <sup>®</sup> SVC are unequivocally marked by the contents of the nameplate.	Conforms the EC Low Voltage Directive	ELTROPLAN- <i>REVCON</i> Edisonstraße 3 D-59199 Bönen
<b>Patent rights</b>	The power feedback unit <i>REVCON</i> <sup>®</sup> is protected in Germany and Europe by patents : <b>Patent-No.: DE 3938654C1</b> and <b>Patent-Nr.: 90123584.6-2207.</b> Patent infringements become prosecute.		
<b>Application as directed</b>	<p><b>Power feedback unit <i>REVCON</i><sup>®</sup> SVC</b></p> <ul style="list-style-type: none"> <li>• Must only be operated under the conditions prescribed in these instructions.</li> <li>• Are components <ul style="list-style-type: none"> <li>– to feedback electrical energy.</li> <li>– used for installation into a machine.</li> <li>– used for assembly together with other components to form a machine.</li> </ul> </li> <li>• Are electric units for the installation into control cabinets or similar enclosed operating housing.</li> <li>• Comply with the requirements of the Low-Voltage Directive</li> <li>• Are not machines for the purpose of the Machinery Directive</li> <li>• Are not to be used as domestic appliances, but only for industrial purpose.</li> </ul> <p><b>Drive systems with power feedback unit <i>REVCON</i><sup>®</sup> SVC</b></p> <ul style="list-style-type: none"> <li>• Comply with the EMC-Directive if they are installed according to the guidelines of CE-typical drive systems.</li> <li>• Can be used <ul style="list-style-type: none"> <li>– on public and non-public mains.</li> <li>– in industrial as well as residential and commercial premises.</li> </ul> </li> <li>• The user is responsible for the compliance of this application with the EC directives .</li> </ul>		
<b>Liability</b>	<ul style="list-style-type: none"> <li>• The information, data and notes in these Operating Instructions met the state of the art at the time of printing. Claims referring to power feedback units which have already been supplied cannot be derived from information, illustrations and descriptions given in these Operation Instructions.</li> <li>• The specifications, processes and circuitry described in these Operating Instructions are for guidance only and must be adapted to your own specific application. ELTROPLAN-<i>REVCON</i> does not take responsibility for the suitability of the process and circuit proposals.</li> <li>• The indications given in these Operating Instructions describe the features of the product without warranting them.</li> <li>• ELTROPLAN-<i>REVCON</i> does not accept any liability for damage and operating interference caused by: <ul style="list-style-type: none"> <li>– disregarding these instructions</li> <li>– unauthorized modifications to the power feedback unit</li> <li>– operating errors</li> <li>– improper working on and with the power feedback unit</li> </ul> </li> </ul>		
<b>Warranty</b>	<ul style="list-style-type: none"> <li>• Warranty conditions: see sales and delivery conditions of ELTROPLAN-<i>REVCON</i> GmbH.</li> <li>• Warranty claims must be made immediately after detecting defects or faults.</li> <li>• The warranty is void in all cases where liability claims cannot be made.</li> </ul>		
<b>Disposal</b>	<b>Material</b>	<b>recycle</b>	<b>disposal</b>
	Metal	1	-
	Plastic	1	-
	Printed-board assemblies	-	1

### 1.4 EC-Directives / Declaration of conformity

#### 1.4.1 What is the purpose of EC-Directives?

The EC-Directives have been drawn up by the European council to define common technical standards and certification procedures within the European Community. At the moment there are 21 EC-Directives for product sectors. The directives are or will be converted in national laws by the member states. If a certificate is conferred in one member state, it is valid in all other member states automatically.

The directives only describe the basic standards. The technical details are or will be described in harmonized European standards.

#### 1.4.2 What is the meaning of the CE-mark?

After an conformity-assessment-procedure the harmony with the standards of the EC-Directives certified by fixing the CE-mark. Within the EC there are no trading obstacles for a CE-marked product.

Power feedback units with CE-mark themselves are compliant with the Low-Voltage Directive only. . For observing the EMC Directive recommendations are made.

#### 1.4.3 EC-Low-Voltage Directive

(73/23/EEC)

Modified by: CE – Marking Directive (93/68/EEC)

##### General:

- The Low-Voltage Directive is valid for all electrical equipment which is used at a nominal voltage between 50V and 1000V AC and between 75V and 1500V DC together with customary environment conditions. Excluded is e.g. the use of electrical equipment in explosive areas and electrical components of lifts for persons or material.
- Aim of the Low-Voltage Directive is to put only those products into commerce which don't endanger the safety of persons and animals as well as the preservation of material assets.

**EC-declaration of conformity**

**According to the EC-Low Voltage Directive /73/23/EEC)**

Modified by: CE – Marking Directive (93/68/EEC)

The power feedback units REVCON® SVC have been developed, designed and manufactured in accordance with the above mentioned EC-Directive and in sole responsibility of

**ELTROPLAN-REVCON Elektrotechnische Anlagen GmbH,  
Edisonstraße 3, D-59199 Bönen**

Considered standards:

<b>Standard</b>	
DIN VDE 0160 5.88 +A1 / 4.89 +A2 / 10.88 PRDIN EN 50178 Class VDE 0160 / 11.94	Equipement of power installations with electronic components
DIN VDE 0100	Guidelines for the desing of power installations
EN 50529	IP type of protection
DIN EN 50081 Part 2 3.94	Basic standard noise emission
DIN EN 50082 Part 2 3.85	Basic standard noise emission

### 1.4.4 EC-Directive Machinery

(89/392/EEC)

Modified by:

1. modification guideline (91/368/EEC)
  2. modification guideline (93/44/EEC)
- CE – marking guideline (93/68/EEC)

#### **General:**

As defined by the machinery guideline a „machine“ is a unit of combined components or devices, from which at least one has moving parts, and of handling devices, control and energy circuits and so on, which have been combined for a specific application (like treating, moving, processing of a material).

**EC-declaration of the manufacturer**

**In the sense of the EC-Directive Machinery (89/392/EEC)**

modified by:

1. Modifying Directive (91/368/EEC)
2. Modifying Directive (93/44/EEC)
- CE – Labelling Directive (93/68/EEC)

The power feedback units *REVCON*<sup>®</sup> SVC have been developed, designed and manufactured in accordance with the above mentioned EC Directive in exclusive responsibility of

**ELTROPLAN-REVCON Elektrotechnische Anlagen GmbH,  
Edisonstraße 3, D-59199 Bönen**

When installing the machines, commissioning (i.e. the starting of operation as directed) the power feedback units is prohibited until it is proven that the machine corresponds to the regulations of the EC Directive 89/392/EEC (Machinery Directive).

## 2 Safety information



### Safety and application notes for controller

(to : Low-Voltage Directive 73/23/EEC)

#### 1. General

During operation, power feedback unit may have, according to their type of protection, live, bare, in some cases also movable or rotating parts as well as hot surfaces.

Non –authorized removal of required cover, inappropriate use, incorrect installation or operation, creates the risk of severe injury to persons or damage to material assets.

Further information can be obtained from the documentation.

All operations concerning transport, installation and commissioning as well as maintenance must be carried out by qualified, skilled personnel (IEC 364 and CENELEC HD 384 or DIN VDE 0100 and IEC-Report 664 or DIN VDE 0110 and national regulations for the preventions of accidents must be observed).

According to this basic safety information qualified skilled personnel are persons who are familiar with the erection, assembly, commissioning and operation of the product and who have the qualifications necessary for their occupation .

#### 2. Application as directed

Power feedback units are components which are designed for installation in electrical systems or machinery.

When installing in machines, commissioning of the power feedback unit (i.e. the starting of operation as directed) is prohibited until it is proven, that the machine corresponds to the regulations of the EC Directive 83/392/EEC (Machinery Directive); EN 60204 must be observed.

Commissioning (i.e. starting operation as directed) is only allowed when there is compliance with the EMC-Directive89/336/EEC.

The power feedback units meet the requirements of the Low-Voltage Directive 73/23/EEC. The harmonized standards of the prEN 50178/DIN VDE 0160 series together with EN 60439-1/DIN VDE 0660 part 500 and EN 60146/DIN VDE 0558 are applicable for the power feedback unit. The technical data and information on the connection conditions must be obtained from the nameplate and the documentation and must be observed in all cases.

#### 3. Transport, Storage

Notes on transport, storage and appropriate handling must be observed

The power feedback unit has to protected from inadmissible stress. In particular during transport and handling no components are allowed to be bend and / or isolating distances may not be altered. The units are equipped with electrostatic sensitive devices, which may be damaged by improper handling. Therefore it has to be avoid to get in contact with electronic components. If electronic components are damaged mechanically the unit must not be put into operation, as it cannot be ensured, that all relevant standards are observed. Climatic conditions must be observed according to prEN 50178

#### 4. Erection

The devices must be erected and cooled according to the regulations of the corresponding documentation.

The power feedback units must be protected from inappropriate loads. Particularly during transport and handling, components must not be bent and / or isolating distances must not be changed. Touching of electronic components and contacts must be avoided.

Power feedback units contain electro-statically sensitive components which can easily be damaged by inappropriate handling. Electrical components must not be damaged or destroyed mechanically (health risk are possible!).

#### 5. Electrical Connection

When working on live power feedback units, the valid national regulations for the prevention of accidents (e.g. VBG 4) must be observed. Before any installation or connection works, the pant has to be switched off and to be secured properly.

The electrical installation must be carried out according to the appropriate regulations (e.g. cable cross-sections, fuses, PE-connection). More detailed information is included in the documentation. When using the power feedback unit with controllers without safe separation from the supply line (to VDE 0100) all control wiring has to be include in further protective measures (e.g. double insulated or shielded, grounded and insulated) .

Notes concerning the installation in compliance with EMC – such as screening, grounding, arrangement of filters and laying of cables – are included in the chapter installation of this documentation. These notes must be also observed in all cases for power feedback units with the CE-mark. The compliance with the required limit values demanded by the EMC legislation is the responsibility of the manufacturer of the system or machine.

#### 6. Operation

Systems where power feedback units are installed, if applicable, have to be equipped with additional monitoring and protective devices according to the valid safety regulations e.g. law on technical tools, regulations for the prevention of accidents, etc. .

After disconnecting the power feedback unit from the supply voltage, live parts of the power feedback unit and power connections must not be touched immediately, because of possibly charged capacitors. For this, observe the corresponding labels on the drive controllers.

During operation, all covers and doors must be closed.

#### 7. Maintenance and service

The manufacturer's documentation must be observed.

**This safety information must be kept!**

The product-specific safety and application notes in these Operating Instructions must also be observed!

## 2.1 General safety information

- These safety regulations are not entitled to completeness. In case of questions please contact our technicians.
- When commissioning the power feedback units is compliant with the state of the art. The power feedback unit generally allows safe operation.
- The statements of this manual describe the attributes of the products without guaranteeing them.
- The power feedback unit may expose persons, the power feedback units itself and other material to danger, if
  - non qualified personal works at and with the power feedback unit.
  - The power feedback units is used in opposite to its purpose.
- Power feedback units have to be projected in a way, that they fulfil their function and don't expose persons to danger, if they are mounted correctly and are used in accordance with their purpose. This applies also for the interplay with the whole plant.
- The units, operational data and circuit details described in this manual have to be understood analogously and have to be checked for transferability to each application.
- For the reasons of personal safety, the observance of the EMC-regulations and for the regular cooling the operation of the device is only allowed with a closed cover of the housing and with mounted flanges!
- Use the drive system only in flawless condition.
- Modifications of the power feedback units without consultation of a REVCON<sup>®</sup>-technician are not allowed generally.

## Safety information

- The warranty given by us expires, if the unit is modified or (even partially) dismantled or if it is used in contradiction to our instructions.
- The constructor of the plant, who has to know the technical guidelines, bears the responsibility for the correct selection and arrangement of the electrical components.
- Putting into operation of the power feedback unit is only admissible at VDE-conform nets of electrical power supply. Non observance may damage the device!
- In accordance with the corresponding standards and guidelines the operation on even for a short time over-compensated networks ( $\cos\varphi \leq 1$ ) respectively on un-choked compensation-units is not admissible. If this is done nevertheless, overvoltages will occur (caused by oscillating currents), which may damage all connected components, especially electronic units like controllers and power feedback units.
- To low powered or unloaded generators and to regulating transformers it is never allowed to feed back power without a previous consultation of our application department. Otherwise unintended voltage rises / excess voltages are generated, which may damage or destroy REVCON<sup>®</sup> and combined units!
- Before operating at nets without reference to neutral ground additional safety measures (e.g. installation of over voltage suppressors like MOV's) have to be done. If necessary, please ask for technical support by our technicians.
- An undisturbed operation of the power feedback unit is only probable, if the following instructions are observed. If these instructions are not observed, tripping of the unit and damages may occur.
  - ◆ Pay attention to the correct values of mains and DC-bus voltage.
  - ◆ Separate power and control wires (> 15cm)
  - ◆ Use shielded or twisted control wires. Connect both ends of the shield to ground!

- ◆ When using the digital input devices, only use suitable switching devices, whose contacts are able to switch the connected voltages.
  - ◆ Connect the housings of drive, controller and power feedback unit to ground carefully. Connect shields of power cables to ground at both ends with as big surface as possible (remove lacquer)!
  - ◆ Connect the cabinet or the plant by a star-shaped network to ground (ground loops have to be avoided!)
- 
- The power feedback unit has been designed for a fixed connection to mains only. Especially when using RFI-filter leakage current values > 3,5mA may occur. The cross section of the earthing conductor must be at least 10mm<sup>2</sup> copper, or a second conductor has to be connected in parallel (star shaped grounding network).
  - If components are used, which have no electrical separated inputs / outputs it is necessary to equalize the potentials (e.g. by a equalizing wire). If this is not observed, these components may be damaged by equalizing currents.
  - When carrying out an insulations test in accordance with VDE0100/part 620 the device has to be disconnected to avoid damage to the power semi-conductors. This procedure corresponds with the standard, as each device performs a high voltage test in accordance with VDE 0160 (EN 50178) in the course of final testing after manufacturing.

## Safety information

- A standard fault-current circuit breaker (sensitive on peak currents) is not allowed to be used as the only protective measure when using controller and power feedback unit. Caused by a DC-component in the mains current a controller with 3-phase input voltage may prevent a fault-current circuit breaker from tripping in case of a earth fault. In accordance with VDE 0160 a fault-current circuit breaker is not allowed to be used as the only protective measure. In dependence on the kind of network (TN, IT, TT) further protective measures in accordance with VDE 0100 part 410 are necessary. For a TN-network this may be an over current protection, for a IT-network a insulation supervision with pulscode-measurment. For all kind of networks protective insulation (-transformer) may be used, if required power and length of wires allow that. When selecting a fault current circuit breaker the following measures have to be considered:
  - ◆ The fault current circuit breaker has to be compliant with the VDE 0664 standard.
  - ◆ The tripping current should be 300mA or more, to prevent a premature tripping caused by the leakage current of the controller. In dependence on the load, the length of the motor cables and the usage of a RFI-filter the leakage current may even be much higher.

Faults current circuit breaker, which are sensitive to all kinds of leakage currents, grant a good protection and are suitable as the only protection measurement for one ore three phase controllers. The connection instructions of the manufacturer has to be observed.

## 2.2 Safety-responsible persons

### User

- User is any natural or legal entity, who uses the drive system or by whom order the drive system is used.
- The user respectively his security officer have to grant
  - that all relevant regulations, instructions and laws have to be observed
  - that only qualified personnel works with or at he drive system
  - that the relevant manual is available for the personnel during any works.
  - that non-qualified personnel is prohibited to work on the drive system.

### Qualified personnel

Qualified personnel are persons who are, based on their education, experience, instruction and knowledge about standards and guidelines, regulations for the prevention of accidents and the situation in the plant, authorized by the safety officer of the plant to execute the necessary works and are able to recognize possible dangers and to avoid them.

(Definition of qualified personnel in accordance with IEC 364)

## 2.3 Usage as directed

Power feedback units are electrical drive components, which are directed to be installed in electrical plants or machines. They have to be used only for drive systems with infinity variable speed controls of 3-phase asynchronous or permanent magnet motors. The usage with other electrical loads is not permitted and may damage the devices. The power feedback unit may only be connected to symmetrical networks. Non-observance may damage the devices.

# Safety information

## 2.4 Layout of the safety information

- All safety notes have a uniform layout:
  - The icon characterizes the type of danger.
  - The signal word characterizes the severity of danger.
  - The note describes the danger and suggests how to avoid the danger.



---

### Signal word

Note

---

	Icons used		Signal words	
Warning of danger to persons		Warning of hazardous electrical voltage	<b>Danger!</b>	Warns of impending danger. Consequences if disregarded: Death or very severe injuries.
		Warning of a general danger	<b>Warning!</b>	Warns of potential, very hazardous situation. Possible consequences if disregarded: Death or very severe injuries.
			<b>Caution!</b>	Warns of potential, hazardous situation. Possible consequences if disregarded: Light or minor injuries.
Warning of danger to material			<b>Stop!</b>	Warns of potential damage to material. Possible consequences if disregarded: Damage of the drive system or its environment.
Other notes			<b>Note!</b>	This note designates general, useful notes. If you observe it, handling of the power feedback unit / drive system is made easier.

## 2.5 Residual hazards



### Operator's safety

After mains disconnections, the power terminals + and – remain live for several minutes.



---

### Protection of the device

Cyclic connection and disconnection of the supply voltage at terminals L1, L2 und L3, may overload the internal input current limitation:

Allow at least 1 minute between disconnection and reconnection.

---

## 2.6 General instructions

By these information to erectors and users of a plant hints on properties and directions concerning the power feedback unit are given. These hints are not entitled to completeness.

### Special features in comparison towards a chopper

Unlike a braking resistor a power feedback device isn't a constant sink, but it's dependent on the momentary characteristics of the supplying net. Commutation brake downs and voltage-flicker in the net have an considerable effect to the backward current of the device. In case of a short time voltage brake down the backward current has to rise correspondingly to feedback the demanded power-amount. Does the level of the supply voltage sink for a longer time, the maximum feedback power is reduced.

If only one phase fails, the device is able to work on, but the current in the two remaining conductors will rise up to 150% of the normal level.

**Length of the DC-connection**

The maximum inductivity of the DC-connection between output B6 bridge of the inverter and the power feedback device mustn't exceed a certain level, as this inductivity induces an additional voltage to the DC-bus, when the IGBT's are switched off . To avoid an overload to the components of the power feedback unit, this additional voltage must not exceed 100V. Resulting from this and other relevant characteristics of the power feedback unit (DC-capacity and absolute maximum value of the grid current) the maximum inductivity

$$L_{\max} = \frac{C \cdot (\Delta U_{GL})^2}{\hat{i}^2}$$

can be calculated. This inductivity always has to be higher

or equal than the sum of the DC-bus inductivity of the frequency inverter and the conductor inductivity of the DC connection. The DC-bus inductivity of the frequency inverter has only to be considered, if it is placed between the inverter B6 bridge and the power feed-back unit. The cables, which are normally used for power applications, have an inductance per unit length of about 0,6µH/m. If the values of the input capacitance C, the during power backfeeding maximum allowed rise of the DC-voltage  $\Delta U_{GL} = 100V$ , the top level of the AC-current of the device ( $=2xI_{eff}$ ), the inductance per unit length  $L'$  and the inductance of the DC-bus 'choke  $L_{ZKD}$  are known the maximum longitude of the conductors can

be calculated with the following equation:

$$l_{\max} = \frac{C \cdot \Delta U_{GL}^2}{\hat{i}^2 \cdot L'} - \frac{L_{ZKD}}{L'}$$

**Typical capacitance of the DC-connection inside the power feedback unit :**

REVCON®-type	Power	DC-capacitance
SVC	7-45kW	100µF
	70-135kW	200µF
	160-200kW	420µF

Table 2.6.1

Example:

$$C=200\mu F, \Delta U_{GL}=100V, i=271A, a=80mm, r=8,5mm, \mu_0=1,257 \cdot 10^{-6} \text{ H/m} \Rightarrow$$

$$l_{\max}=26m$$

For longer DC-Bus-wires additional capacitors have to be installed (please get in contact with our application-department if the occasion arrises).

**Operation on a generator**

The usage of a power feedback unit within an island network (e.g. with an diesel generator) is possible, but there are restrictive regulations concerning the power limits.

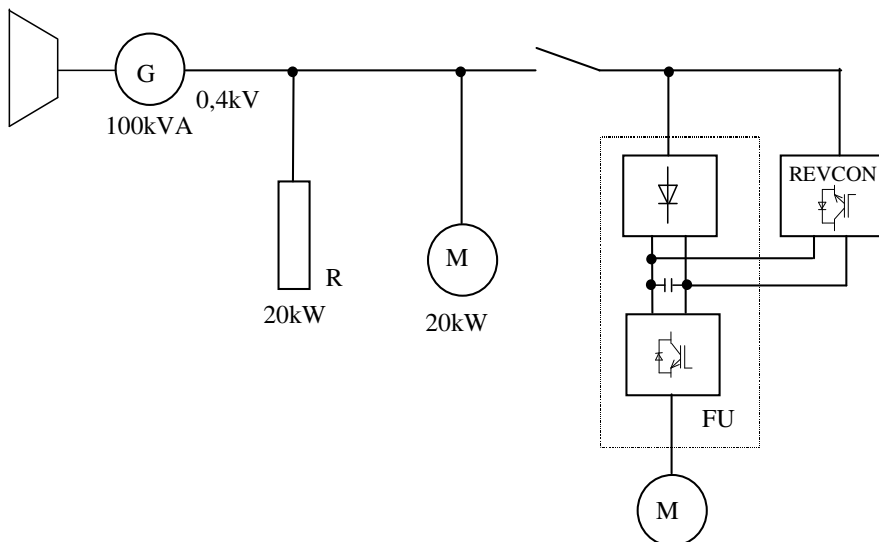

Figure 2.6.1

Within a network, that is assembled like in figure 2.6.1, there are two additional restrictions: First the power of the motor connected to the inverter must be lower than half of the nominal power of the generator. Second the total amount of the power of the two other loads must be more than double of the backfeed-power.

If these conditions aren't checked up a change from motory to generatory operation may result in load shocks. These shocks are too dynamic for the voltage regulator of the generator. The regulator reacts with an overshoot and as a result of this with an over voltage within the island network.

---

**STOP!**



**Over voltages may cause serious damages to the connected frequency inverter and /or to the power feedback unit and to the other loads.**

---

**Operation on a transformer**

If only a few loads operate within a network section the connected transformer must be able to transport the in this section not used power back to the next voltage level without producing a not allowed voltage increase inside the section. Therefore the nominal power of the transformer has to be one and a half higher than the backfed power out of the section, so that also the harmonic and reactive components of the current can be transmitted. In the network section displayed in figure 2.6.2 these conditions are checked up, even if the other loads are switched off.

Is the backfed power in the order of the nominal power of the transformer, it's impedance voltage has to be small enough (max. 6%) to limit the voltage increase in the section.

The operation of the power feedback unit in combination with an adjusting transformer (e.g. in the case of a braked slip-ring induction motor) is only allowed, if the quotient ratio of feedback-power and nominal power is much smaller than one

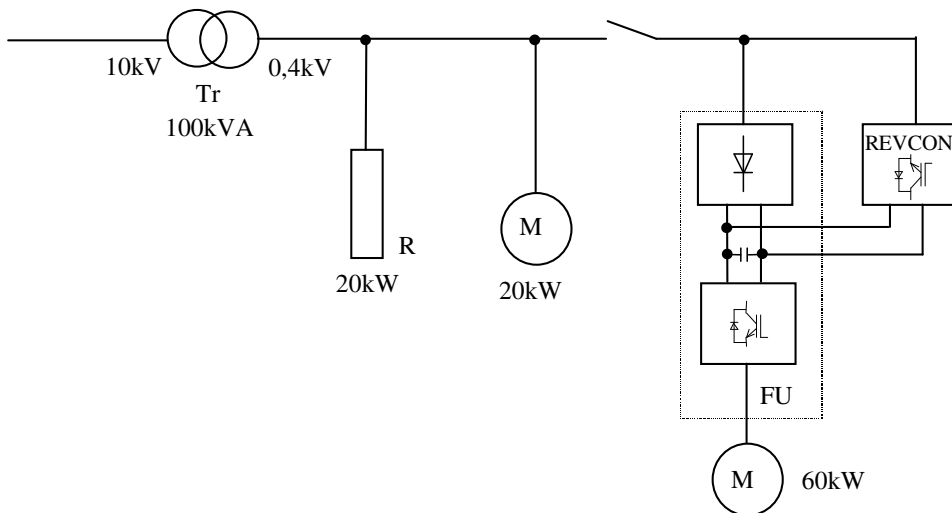

Figure 2.6.2

**Placing of the commutation choke**

If the frequency converter is connected to an external commutation choke, the connection of the power feedback unit has to be done at it's network terminals (figure 2.6.3). Is the connection done at the load terminals of the commutation choke it's inductivity prevents the synchronising to the supplying net and the induction voltage of the choke when it is switched of under load may result in damages to the power feedback device.



**STOP!**

**Over voltages may cause serious damages to the connected frequency inverter and /or to the power feedback unit and to the other loads.**

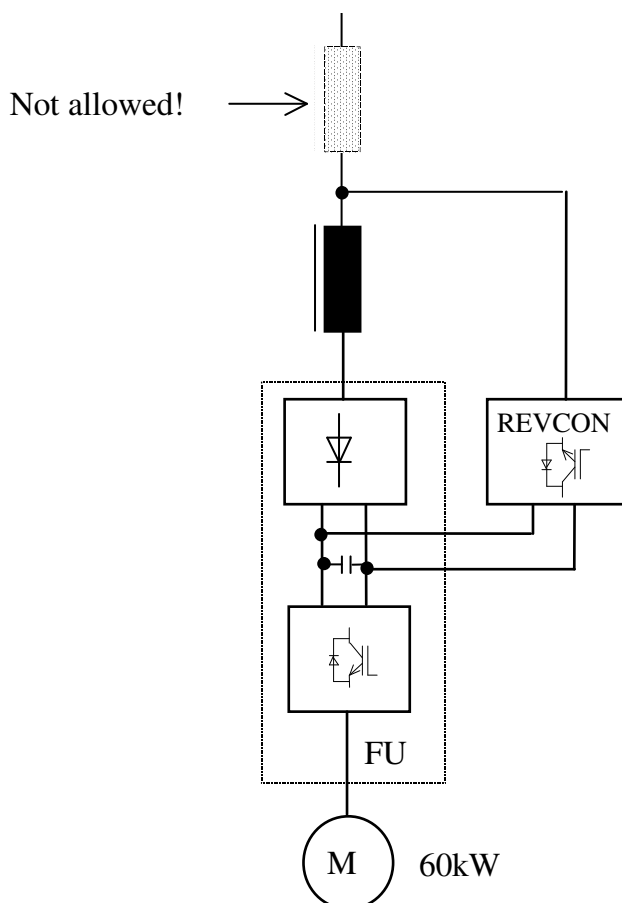

Figure 2.6.3

The same things apply to the also non-admissible pre-connection of further commutation chokes.

# Safety information

## Line and contact resistances

The values of current carrying capacity of conductors refer to the most often used copper conductors. Concerning to it's higher specific resistance aluminium conductors must have greater dimensions.

Regardless of which conducting materials is used, the contact terminals of the conductors have to be low resistive and their number has to be reduced to the necessary minimum.

Too much or too high resistive terminals may result in a unsafe voltage magnification during the power feedback operation.

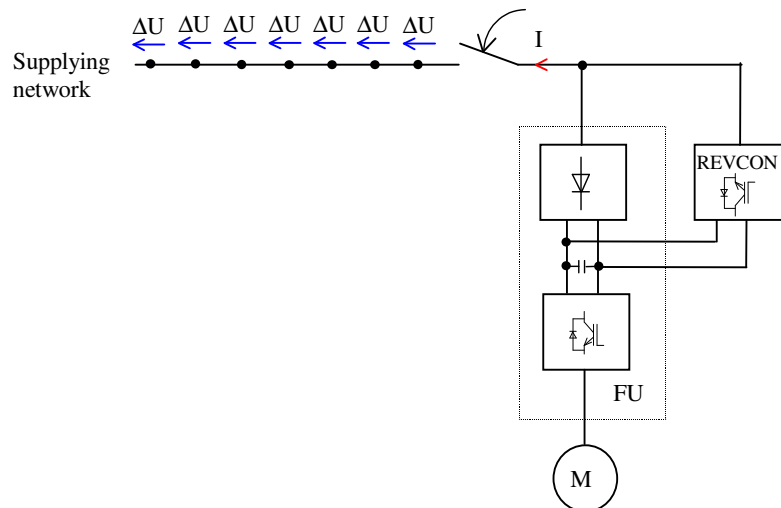

Figure 2.6.4

Proceeding from a stable network with e.g. 400V nominal voltage and a backward current of 80A, at a bad made terminal of 100mW a voltage of 8V is dropped (A good made terminal has got a resistance of ca 1 mW.). During backfeed operation at seven serial terminals at the net switch there results an voltage of 456V.

**STOP!**



Over voltages may cause serious damages to the connected frequency inverter and /or to the power feedback unit and to the other loads.

**Current capacity of copper conductors for frequency inverters and power feedback operation**

conductor cross section (mm <sup>2</sup> ) per phase	conductor radius (mm)	fuse (A)	max. permanent current (A)
16	2,3	63	46
25	2,8	80	59
35	3,3	100	73
50	4,0	125	90
70	4,7	160	106
95	5,5	200	140
120	6,2	250	206
185	7,7	315	250
2x120	2x6,2	400	300
2x150	2x6,9	500	390
2x185	2x7,7	630	485
3x185	3x7,7	800	570
3x240	3x8,7	1000	740
4x240	4x8,7	1250	920

These values are based on a cable length of 100m and a maximum voltage drop of 5V..

Table 2.6.2

# Safety information

## Connection of further loads

The connection of further loads ( e.g. cabinet ventilation or climatisation) parallel to the frequency inverter / power feedback unit at a common circuit breaker like in figure 2.6.5 is not allowed. If it's done nevertheless, in case of tripping of the circuit breaker the connection to the network ( energy sink and synchronising element for the power feedback unit) misses. The IGBT's now switch the DC-voltage directly to the other loads. The resulting nearly rectangular "net"-voltage drives a current through the loads, which level and form depends on their impedance. If the power consumption of the loads is too small, the DC-voltage and also the output voltage of the power feedback unit rises during the backfeed operation. This increased voltage may damage all connected components.

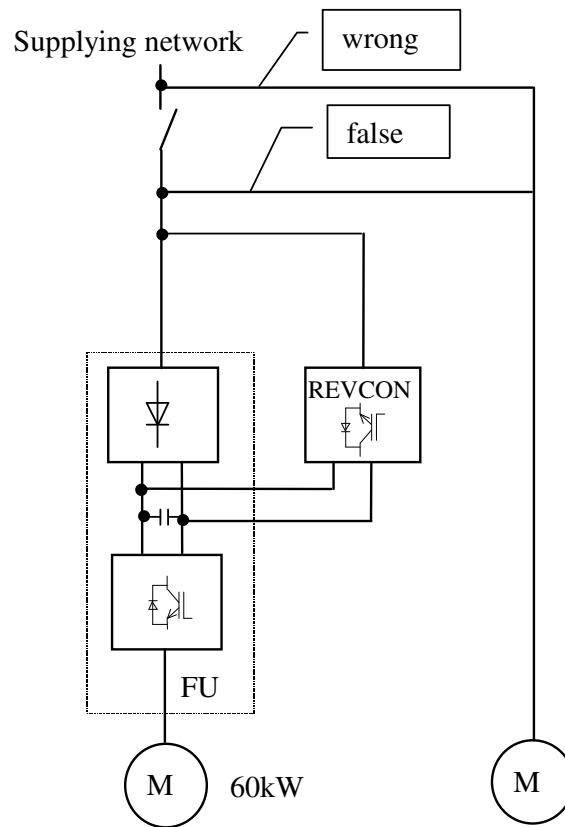

Figure 2.6.5



**STOP!**

Over voltages may cause serious damages to the connected controller and /or to the power feedback unit and to the other loads.

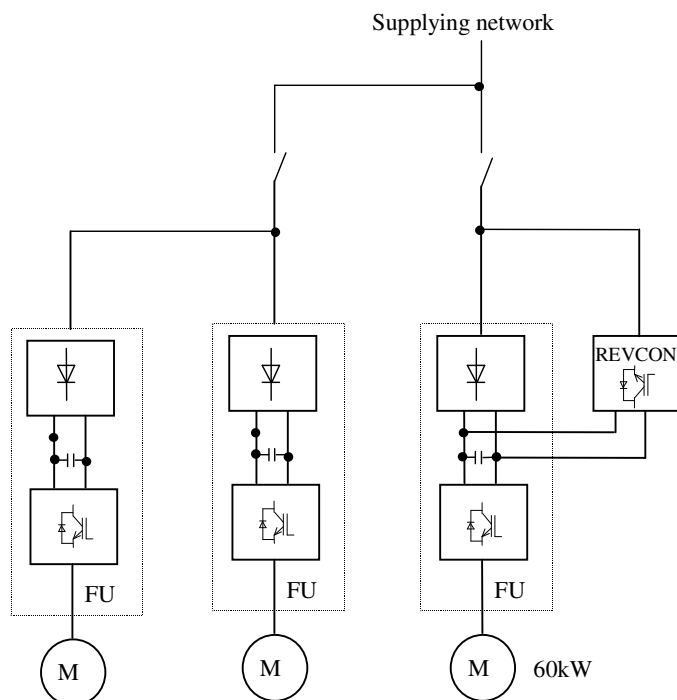

Figure 2.6.6

**F**

**TIP!**

Same things apply to the structure like in figure 2.6.6. Even in this case it is necessary to place a circuit breaker in each backfeeding current circuit.

### Unchoked compensation plants and resonance rise

Compensation plants are used in the centre of the power supply of a company. Disturbances or damages at these plants have effects on the power supply and may result in interrupted production processes.

Although this is no longer state of the art, many compensation plants are in operation without any choking. The problems which result from a usage of such an unchoked compensation plant are manifold:

- direct resonance
- resonance rise
- switching transients or
- impairments of centralized ripple systems

The fact, that a company produces back effects to the power supply is not the only reason for the creation of resonance. Decisive for the risk, to generate a resonance is the compensation power at the medium voltage transformer. The higher this power is, the higher is the risk of resonance. The second important factor is the harmonic load of the medium voltage level. This harmonic load is transmitted via the transformer and causes effects on the low voltage level. Most often the limits were exceeded for the 5th harmonic component.

### **3 Technical data**

#### **3.1 Characteristics**

- Small compact housing
- Braking power of controller is fed back into mains
- Power range 4kW to 350KW
- Up to 4 units can be paralleled (more on request)
- DC-bus coupling of several controllers possible
- IGBT power modules with high efficiency and high service reliability
- Self synchronising
- Overload protection during backfeeding operation
- Supervision of mains voltage, phase sequence and temperature
- High efficiency
- High dynamic braking processes are possible
- User-friendly commissioning – no adjustment necessary
- Including built in harmonic filter SKS-R

## Technical data

### 3.2 General data / application conditions

Area	Values
Permissible temperature range*	During transport of the unit: -25°C...+70°C (to VDE 0160) During storage of the unit: -25°C...+55°C (to VDE 0160) During operation of the unit: 5°C... +40°C without power derating 40°C...+55°C with power derating
Humidity class*	Humidity class F without condensation ( 5% - 85% relative humidity)
Installation height h*	H ≤ 1000 m a.m.s.l. without power derating 1000 m a.m.s.l. < h 4000 m a.m.s.l. with power derating
Air pressure*	86kPa – 106kPa to VDE0875 part 11 and prEN55082
Degree of pollution	VDE 0110 Part 2 degree 2
Noise immunity	EN 61000-4-4 degree 4 EN 61000-4-2 degree 3 EN 50082-2 criterion A
Insulation strength	Overvoltage category III according to VDE 0110
Packaging	DIN 55468 for transport packaging materials
Type of protection	IP 20
Approvals	CE: Low-Voltage Directive

\*climatic conditions according to class 3K3 (EN 50178 Part 6.1)

### 3.3 Rated data

#### 3.3.1 Power feedback unit

REVCON type		SVC(S) 400V
Nominal range of the interlinked mains voltage	$U_N[V]$	$380 \leq U_N \leq 415$
Tolerance of the interlinked mains voltage	$U_N[V]$	$342 \leq U_N \leq 456$
Mains frequency	$f_N[Hz]$	$50 \pm 2 \%$
Overload capability		ca. 1,2 x Irms (dynamic)
Efficiency	$\eta[\%]$	Ca. 96 % (4 % therm. losses)
Power factor* <sup>3</sup>	$\cos\phi$	~ 1
Total harmonic distortion* <sup>3</sup>	THDI [%]	< 16%
* <sup>1</sup> need of airflow	m <sup>3</sup> / h	a) SVCS 7-400, 13-400, 22-400, : 200 b) SVCS 33-400 : 350
Power derating	[%/K]	$40^\circ C < T_a < 55^\circ C \Rightarrow 3\%/K$
	[%/m]	$1000m \text{ a.m.s.l.} < h \leq 4000m \text{ a.m.s.l.} \Rightarrow 5\%/1000m$

**Table 3.3.1.1**

\*<sup>1</sup> depending on the size of the unit ( nominal power and nominal voltage)

\*<sup>2</sup> alternative case-type with minor changed dimensions

\*<sup>3</sup> at nominal current

**3.3.2 Current load**

Nominal voltage 400V

<i>REVCON</i> <sup>®</sup> - Typ	AC max. current $I_{rms}$	DC max. current $I$
SVCS 7-400-1-0	11 A	13 A
SVCS 13-400-1-0	20 A	24 A
SVCS 22-400-1-0	32 A	38 A
SVCS 33-400-1-0	48 A	58 A

**Table 3.3.2.1**

**F**

**NOTE!**

To calculate the correct value of regenerating power it is necessary to note, that the real momentary regenerating power is dependent on the real existing main circuit voltage at any time. To calculate the regenerative power the following formula should be used:

$$P = U_{eff} \cdot I_{eff} \cdot \sqrt{3} \cdot \cos\varphi \text{ (during regenerative operation : } \cos\varphi = 1)$$

The maximum possible regenerative power is calculated based on the momentary rms mains voltage and the maximum rms current of the respective device.

Example:

Model SVC(S) 45 with rated feedback power of 45kW , maximum rated rms current 65A (refer to technical data), nominal mesh voltage rating e.g. 400V.

From that results:  $P=400V \times 65A \times \sqrt{3}=45033W$ , that's about 45,0kW

If the momentary rms mains voltage is only 395V or even lower for a short time, the maximum possible regenerative power is reduced as well:

$$P = 395V \times 65A \times \sqrt{3} = 44470W, \text{ that's about } 44,5kW.$$

### 3.3.3 Allowed operating data with max. braking power

- Devices of product line **REVCON<sup>®</sup> SVCS 7-XXX-1-...** without forced cooling have an allowed operating duration of 100%.
- Devices of product line **REVCON<sup>®</sup> SVCS 13-XXX-1-...** without forced cooling have an allowed operating duration of 50% (referring to a cycle time of 10 min.). With forced cooling they have an allowed operating duration of 100%.
- Devices of product line **REVCON<sup>®</sup> SVCS 22-XXX-1-...** with forced cooling have an allowed switch on duration time of 50% (referring to a cycle time of 10 min.).
- For the devices from product line **REVCON<sup>®</sup> SVCS 33-XXX-1-...** the following thermal limited load graphs are valid.

# Technical data

## 3.3.3.1 Thermal limited load graphs

By means of these thermal limited load graphs you can find out the max. switch-on-time depending on the needed braking power. The curves are valid for a max. cooling air temperature of 35°C (95°F).

### Example of an application:

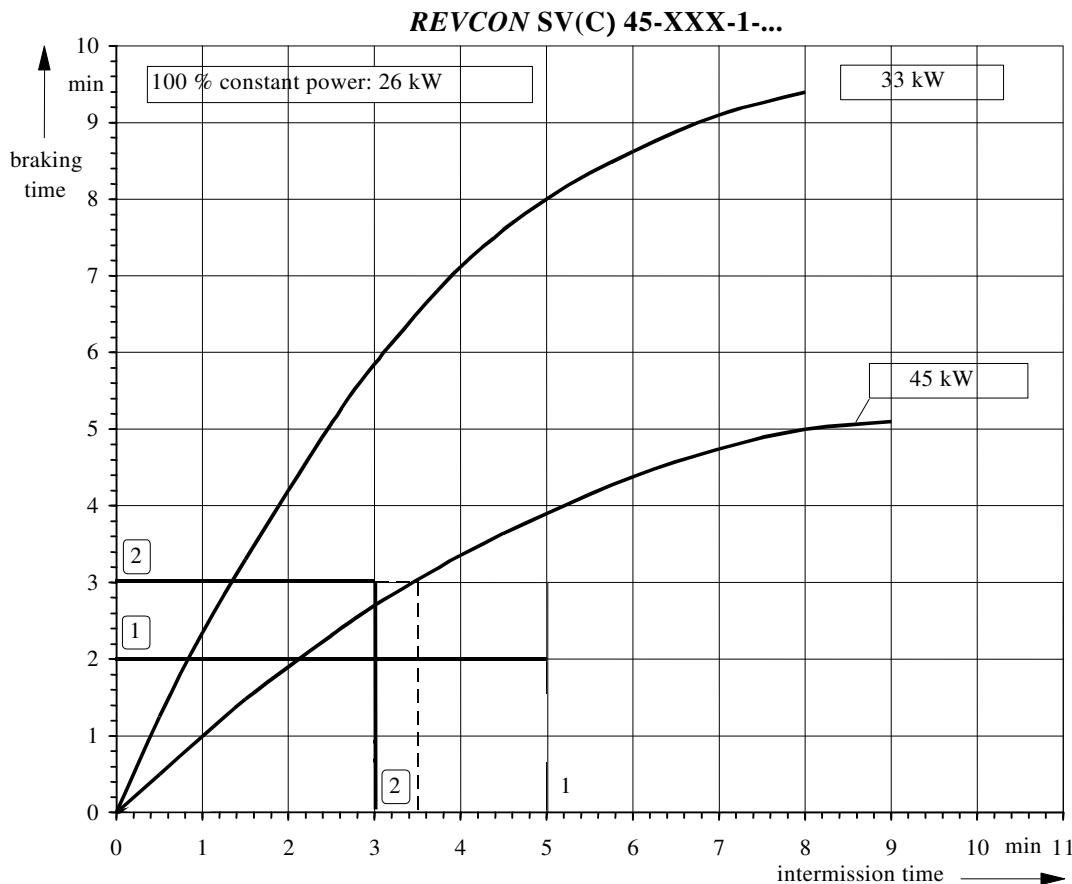

Diagram 3.3.3.1.1

**Example :** necessary braking power : 33 kW  
braking duration : 2 min.  
time between two brakes : 5 min.

Evaluation: In this case the point of intersection of braking time and intermission time is below

the thermal limited power graph in the allowed area (with forced cooling).

Remark: Without forced cooling, the intermission time is 8 minutes.

**Example :** necessary braking power : 45 kW  
braking duration : 3 min.  
time between two brakes : 3 min.

Evaluation: In this case the point of intersection of braking time and intermission time is above the thermal limited power graph. That means this operation cycle is not allowed.

Remark: In case of an intermission time of e.g. 3,5 min. this operation cycle would be allowed again.

**Thermal limited load graphs:**

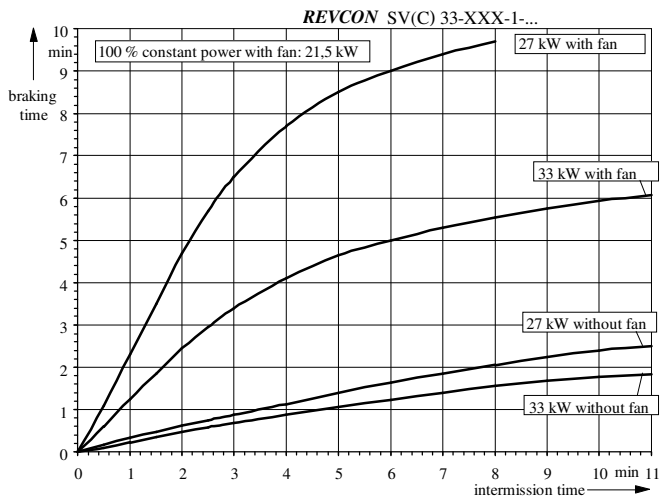

**Diagram 3.3.3.1.2**

## Technical data

### 3.3.4 Fuses and wire cross sections

The power feedback unit is connected to mains supply via the terminals L<sub>1</sub>-L<sub>3</sub> at the commutation choke and PE at the heatsink. Mains fuses must be designed according to the current load capacity of the supply wire.

#### 3.3.4.1 Series fuses

Semiconductor fuses have to be connected in series with the power feedback unit as following tables (refer to figure 4.4.1.1.1 position 1). The listed manufacturer is recommended, but naturally also comparative fuses of other manufacturer (e.g. Jean Müller, Ferraz, Bussmann) are suitable.

<i>REVCON</i> <sup>®</sup> - type	max. fuse AC	Connection terminal and max. cross section of the supply line *
SVCS 7-400-1-0	Siba 50 179 06 20A 660V 10*38mm	CS M5 25mm <sup>2</sup>
SVCS 13-400-1-0	Siba 50 124 06 30A 690 V 14x51mm	CS M6 35mm <sup>2</sup>
SVCS 22-400-1-0	Siba 50 124 06 50A 690 V 14x51mm	CS M6 35mm <sup>2</sup>
SVCS 33-400-1-0	Siba 50 140 06 80A 690 V 22x58mm	CS M6 35mm <sup>2</sup>

**Table 3.3.4.1.1**

ES ≙ end sleeve for strands

CS ≙ cable socket with drill hole for M6 / M8 / M10

\* at the copper lug of the commutation choke.

\*\* at the fuse holder respective disconnecter

### 3.3.4.2 Internal fuses

The power feedback unit is equipped with semiconductor fuses according to the following tables (refer to figure 4.4.1.1.1. position 7). The listed manufacturer is recommended, but naturally also comparative fuses of other manufacturer (e.g. Jean Müller, Ferraz, Bussmann) are suitable.

<i>REVCON</i> ® - type	DC-fuses (use fast acting semiconductor fuses only)	Connection terminal and max. cross section of the supply line **
SVCS 7-400-1-0	Siba 50 124 06 20A 690 V 14x51mm	ES 10mm <sup>2</sup>
SVCS 13-400-1-0	Siba 50 124 06 50A 690 V 14x51mm	ES 10mm <sup>2</sup>
SVCS 22-400-1-0	Siba 50 140 06 63A 690 V 22x58mm	ES 35mm <sup>2</sup>
SVCS 33-400-1-0	Siba 50 140 06 80A 690 V 22x58mm	ES 35mm <sup>2</sup>

**Table 3.3.4.2.2**



---

**Stop!**

If semiconductor fuses (figure 4.4.1.1.1 position 1 and 7) trip, please get in contact with ELTROPLAN-REVCON immediately, as possibly further protective measures have tripped. If internal fuses are exchanged, please verify, that only the original types are used for replacement.

---



---

**Warning!**

**Before replacing a fuse, switch off all voltages!**

---

**3.3.5 RFI-filter**

To observe the EMC-rules. In accordance with figure 4.4.1.1.1 a radio frequency interferences filter class A can be preconceived to the REVCON® unit. In tables 3.3.5.1 to 3.3.5.5 the power feedback units are assigned to the corresponding RFI-filter types.

<b>REVCON® - type</b>	<b>Order designation for filter</b>	<b>Case type</b>
SVC(S) 7-400-1-0	RF-SVC 7-400	1
SVC(S) 13-400-1-0	RF-SVC 13-400	1
SVC(S) 22-400-1-0	RF-SVC 22-400	1
SVC(S) 33-400-1-0	RF-SVC 33-400	1

**Table 3.3.5.1**

**3.3.6 SKS-module**

To decrease the low frequency harmonic back effects to mains a filter module REVCON® SKS-R is built into the power feedback unit .

## 4 Installation

### 4.1 Mechanical installation

#### 4.1.1 Important hints

- Use the power feedback units as build-in devices only!
- Observe free spaces!
  - Several power feedback units in one cabinet may be installed next to each other without spacing.
  - Keep a horizontal distance of at least 70mm to other components and to the cabinet walls.
  - Keep a vertical distance of at least 150mm to other components and to the cabinet walls.
- Ensure that there are no obstacles in the way of the cooling air input and output.
- If the cooling air is polluted (dust, dirt swirl, grease, aggressive gas ) so that the function of the power feedback unit may be impeded
  - Take sufficient countermeasures, e.g. separate cooling air, mounting of air filters, periodical cleaning.
- Do not exceed the ambient temperature permissible during operation.

#### Provided mounting position

The power feedback unit has been designed for vertical wall mounting ( $\pm 15^\circ$ ) only. Mounting is allowed only on a flat surface without using any kind of spacers. This kind of mounting is necessary to guarantee the right way for the cooling air. A power loss of 3 % from the max. nominal power rating has to be calculated. Air-temperature may not exceed 40 °C near the unit. Air-in- and air-out-openings at the top and the bottom of the unit may not be concealed by installation materials such as cable ducts or other equipment. Keep a distance of min. 15 cm to the air-in- and air-out-openings and a distance of min. 7 cm to beside mounted parts or cabinet-walls.

## Installation

### 4.2 Dimensions

#### 4.2.1 Power feedback unit

<b>REVCON<sup>®</sup> Type</b>	<b>H (mm)</b>	<b>H<sub>1</sub> (mm)</b>	<b>H<sub>2</sub> (mm)</b>	<b>B (mm)</b>	<b>B<sub>1</sub> (mm)</b>	<b>T (mm)</b>	<b>T<sub>1</sub> (mm)</b>	<b>e (mm)</b>	<b>f<sub>1</sub> (mm)</b>	<b>f<sub>2</sub> (mm)</b>	<b>f<sub>3</sub> (mm)</b>	<b>weight (kg)</b>
SVCS 7-400-1-0	500		-	245	272	315	-	260	80	--	--	25
SVCS 13-400-1-0	500		-	245	272	315	-	260	80	--	--	30
SVCS 22-400-1-0	500		-	245	272	315	-	260	80	--	--	35
SVCS 33-400-1-0	700		-	245	272	315	-	260	80	--	--	40

Table 4.2.1.2

4.2.1.1 Dimension diagrams

1. SVCS 7-400-... to SVCS 22-400...

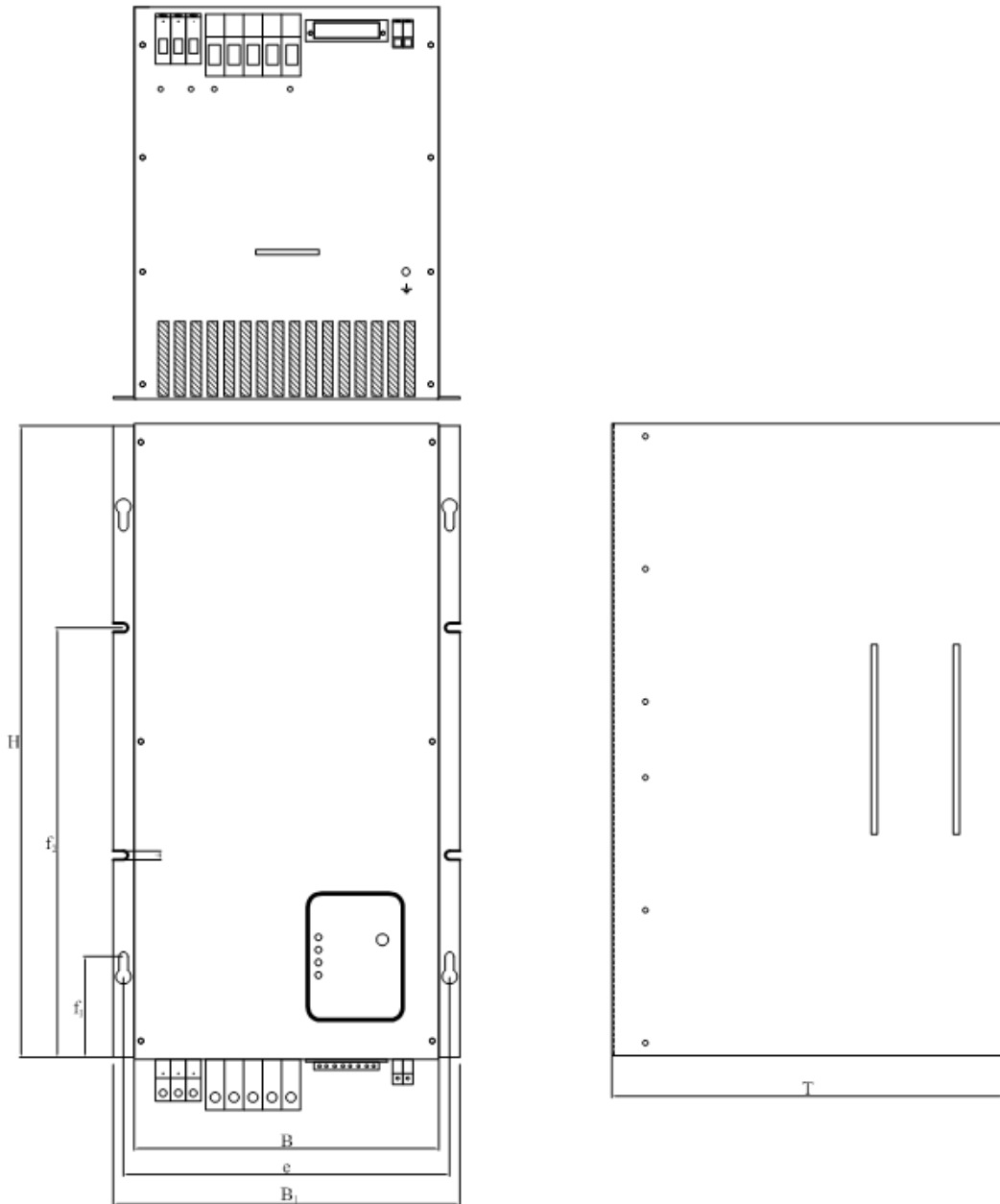

2. SVCS 33-400-...

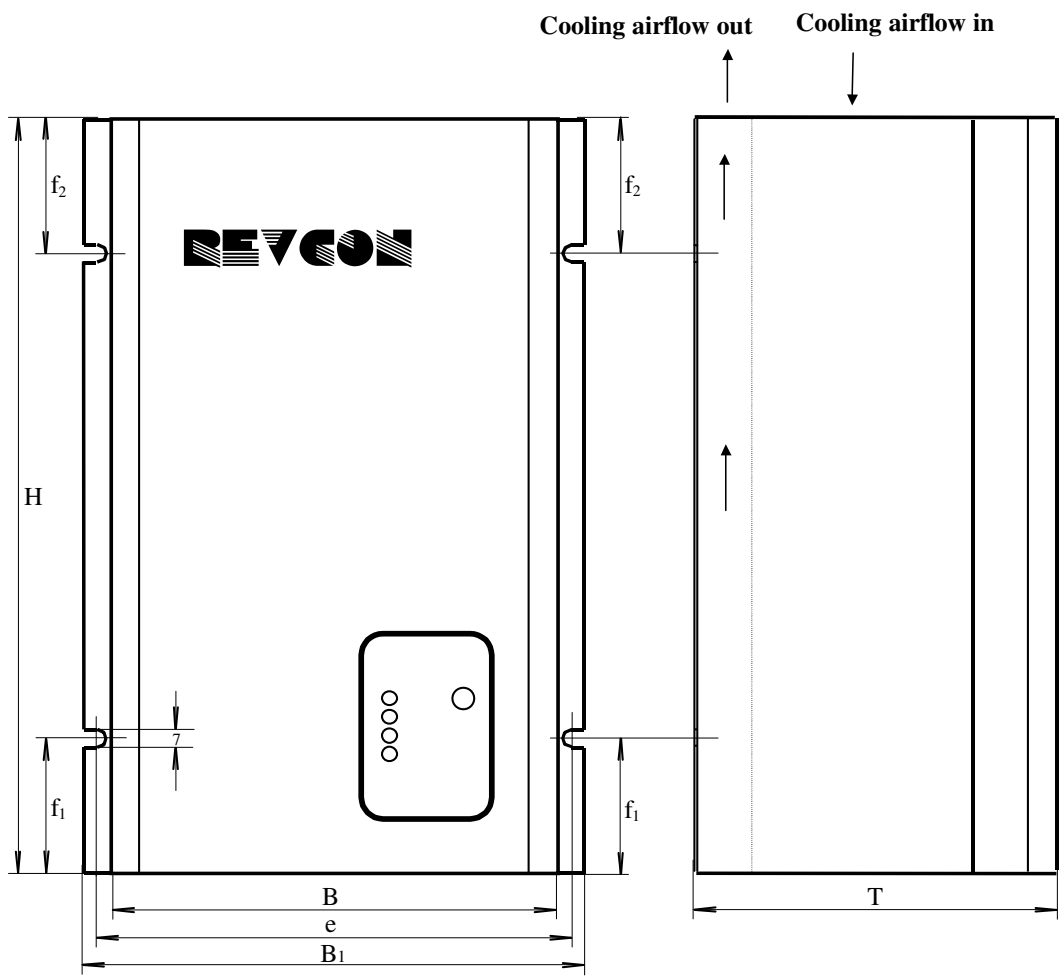

all cableinputs from bottom

## 4.2.2 RFI-filters

The radio interference filter of case-type 1 and 2 are mounted in footprint-housings, which could be placed between cabinet-wall and power feedback unit.

The radio interference filter of case-type 3 and 4 are mounted in housings, which should be placed beside the power feedback unit.

The power feedback units were fixed with screws M6 , the RFI-filter with screws M8.

### 4.2.2.1 Dimension diagrams

#### 1. Diagram Case 1

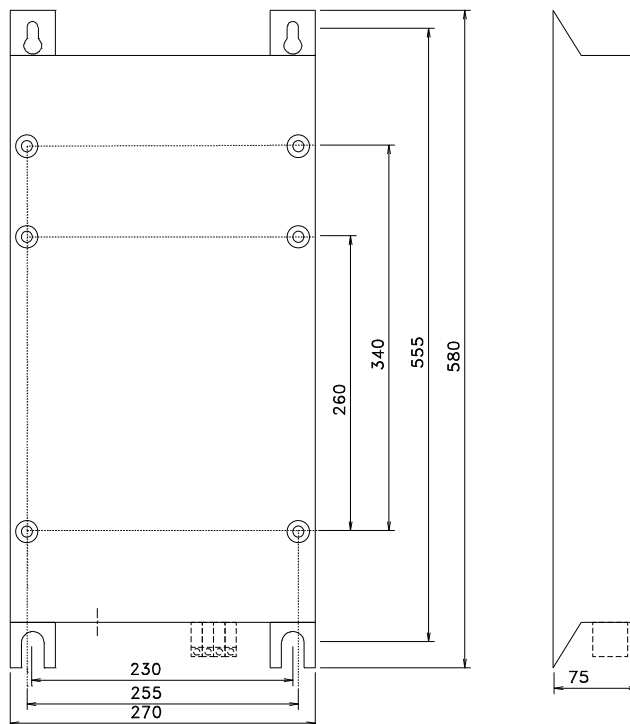

**2. Diagram Case 2**

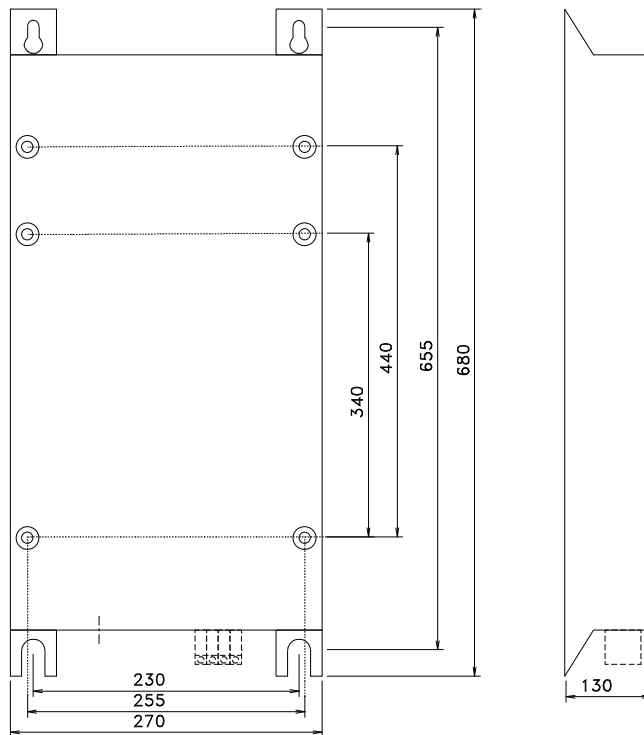

**3. Diagram Case 3**

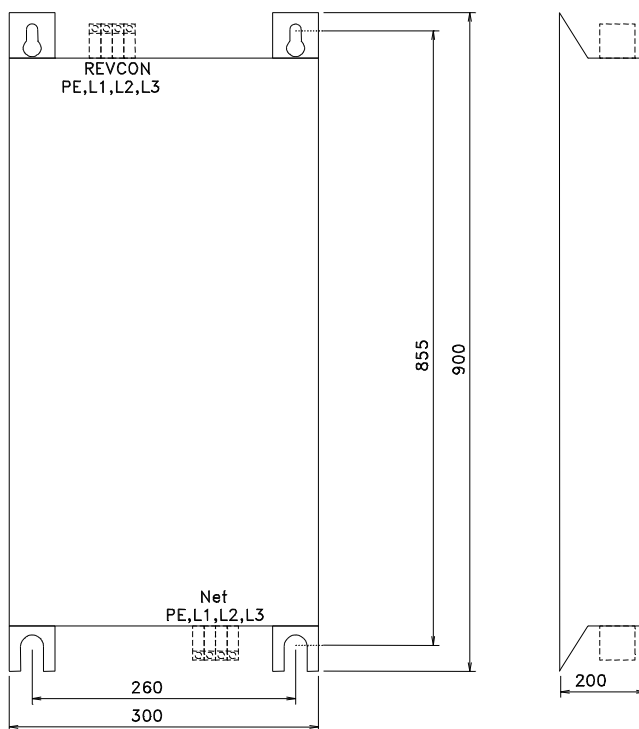

## 4.3 Electrical installation

### 4.3.1 Operator's safety



---

**Danger!**

After mains disconnection, the DC-bus terminals of the power feedback unit remain live for several minutes! The exact time, till this voltage has decreased to a not dangerous value is dependent on the used controller and has to run down before any service operations or similar activities are started.

The exact values have to be cross checked with the documentation of the controller.

---

Replace defective fuses by the regular types (chapter 3.3.3.2) only and without any live voltage.

### 4.3.2 Protection of the power feedback unit



---

**Stop!**

The power feedback units contain electrostatic sensitive devices (ESSD).

During working at the terminals the personnel has to observe the rules of the international standard IEC 747-1 chapter 9. Basically before starting the works the personnel has to free itself from electrostatic voltages:

Discharge yourself by touching the PE-screw of the housing or another grounded surface in the cabinet.

---

### 4.3.3 Mains types / Mains characteristics

Observe the restrictions in accordance to the respective mains type!

If you want to run power feedback units at mains types, which are not listed in the table below please consult our technicians.

VDE conformal mains type	Operation of the power feedback unit	Remark
With grounded star point	Allowed	Observe the technical data of the unit
With isolated star point	After consulting the manufacturer and possible modification of the unit allowed	
With grounded active wire	After consulting the manufacturer allowed	

Table 4.3.3.1

### 4.3.4 Specifications of the used wires

- The used wires have to be compliant with the specifications on site ( e.g. UL or UL-c)
- The regulations about the minimum cross section of PE-wires have to be observed!
- The effectiveness of a screened wire is dependant on
  - a good screen connection
  - a low screening impedance:  
Use screens tin- or nickel-plated copper screens only!
  - the swamp factor of the screen mesh:  
at least 70% to 80% with a swamp angle of 90°
- Protect the mains wires of the power feedback unit with the provided wire protection fuses.

## 4.4 Connection

After removing the lateral screws and the cover of the housing the connection terminals are accessible. The wires should be passed through the metal glands in the flange sheet.



---

### Stop!

When picking up the cover don't damage the wires, which lead to the display!

---

### 4.4.1 Power connection

#### Fusing (also refer to chapter 3.3.4)

- The specifications of chapter 3.3.4 (fuses and wire cross sections) are recommendations and refer to the operation
  - in cabinets and machines
  - installation in cable ducts
  - max. ambient temperature +40°C.
- When choosing the cross section of the wire the voltage drop under load should be considered (refer to chapter 3.4)
- Protection of the wires at mains side (L1, L2, L3):
  - by commercial wire protection fuses.
  - fuses have to be compliant with the relevant standards on site.
  - rated voltage of the fuses have to be compliant with the voltage on site.
- Protection of the power feedback unit at mains side (L1, L2, L3):
  - by commercial semiconductor fuses.
  - fuses have to be compliant with the relevant standards on site.
  - rated voltage of the fuses have to be compliant with the voltage on site.
- Protection of the power feedback unit at DC side (+UG, -UG):
  - fuses are part of the power feedback unit (refer to chapter 3.3.4.2).

**The erector/user of the plant bears the responsibility for the observance of further relevant standards (e.g.: VDE 0113, VDE 0289 and so on).**

## Installation

### Connection

- All connections should be as short and low-impedance as possible.
- For the observance of the EMC-guideline (in accordance to actual standards like VDE 0160 and EN 50178) screened wires have to be used.
- Connect the mains supply wires at the terminals L1, L2, L3 (at the mains choke) of the power feedback unit. Only three phase connection is allowed.
- A defined phase sequence (clockwise rotation field) must be observed at the main circuit connection of the power unit. The power feedback unit is equipped with a phase-sequence control unit. In case of an incorrect rotation field an error message is displayed via LED as follows: "rotation field failure" or "phase failure". In this case two phases, connected to the power unit, have to be exchanged.
- Connect the earthing wire of the supply cables to the earthing screw of the power feedback unit.
- The wires for the DC-bus coupling between controller and power feedback unit have to be connected to the DC-fuse holder. It is absolutely necessary to observe the correct polarity.

**F**

---

### Tipp!

Interchanging of + (PLUS) and – (MINUS) avoids the correct function of the power feedback unit.

---

### 4.4.1.1 Wiring schematic

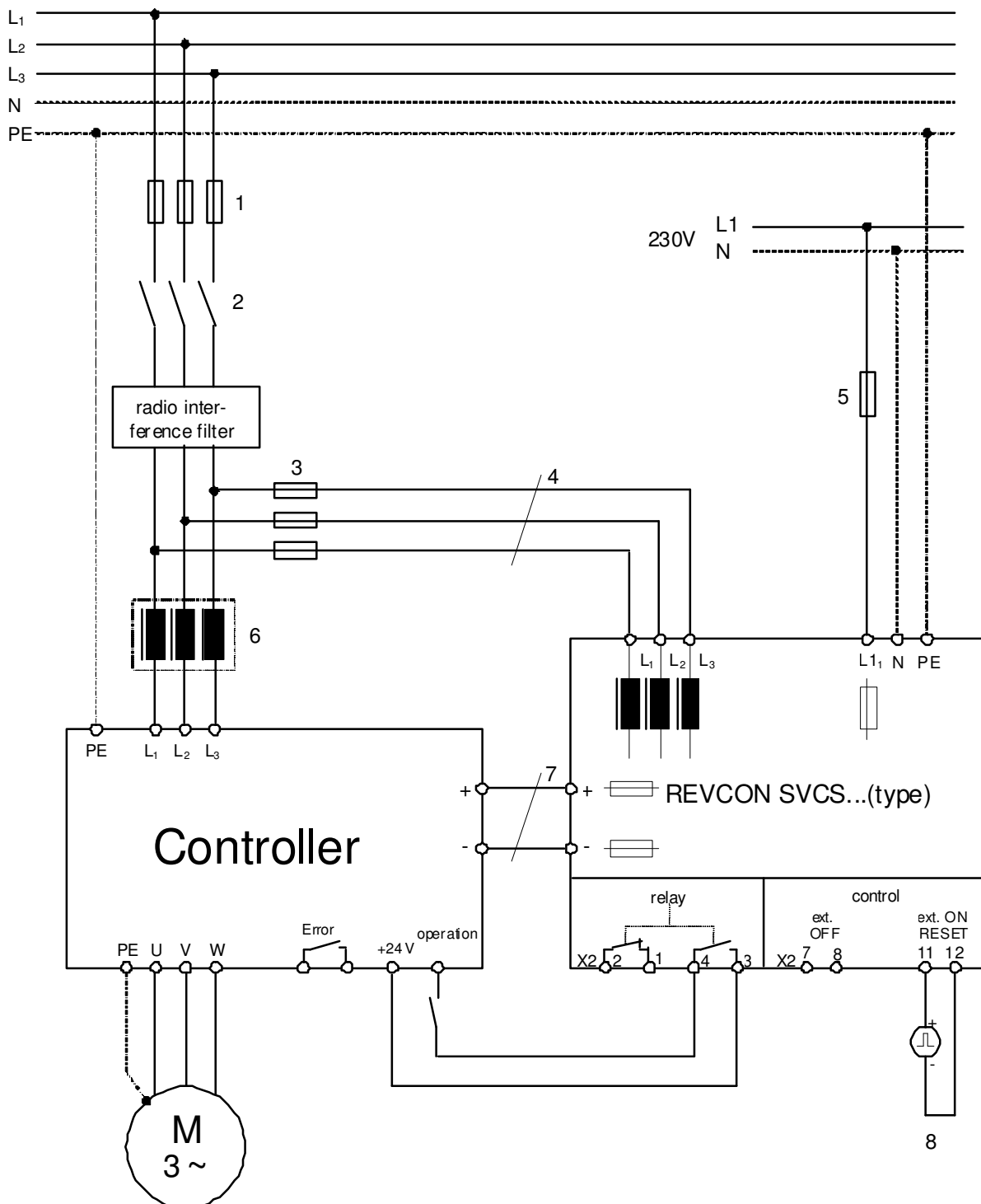

Figure 4.4.1.1.1 Wiring schematic of the power feedback unit *REVCON*<sup>®</sup> SVC(S) and one or more controllers

**Remark:**

This is an wiring example. Special features of a application (e.g. installation of a PLC) may require modifications of the wiring of the terminals X2.1 ... X2.12 .

## Installation

### Legend for figure 4.4.1.1.1 (REVCON® SVCS)

1. Fusing in accordance with controller manual.
2. It is not allowed to connect any other devices except the frequency inverter and the power feedback unit behind the main magnetic switch.



---

#### **Danger**

If this is not observed, you take the risk that, in the case of switching off the mains during feed back the power, the voltage in that sector may rise up to a dangerous level. This may destroy the connected devices and perhaps also the inverter and/or the power feedback unit. To avoid such situation, the power feedback unit is equipped with an overvoltage switch off, but nevertheless this hint should be observed!

---

3. Fusing in accordance with power feedback unit manual. This may be left out, if at position 1 semiconductor fuses or full range fuses are used and if after 1 the cross section of the wires is not reduced.
4. Cross section in accordance with the relevant VDE-rules.
5. Fusing (230 V supply, <2A current input) in accordance with DIN VDE 0298 or short circuit proof wiring.
6. Design of the mains choke in accordance with controller manual (possibly not applicable, if already installed inside the controller).
7. At these terminals one ore more controllers (even with different power ratings) may be attached, like it shown in figure 4.5.1. Even if several controllers are attached, the wires have to be as **short and low impedance** as possible!
8. The „ON“ or „RESET“ signal may be initiated via terminals 9 and 10 or 11 and 12:  
Terminals 9 and 10: potential free contact (short time contact)  
Terminals 11 and 12: positive pulse (12-24 V DC); practicable e.g. via PLC (terminal 11 +, terminal 12 -).

#### 4.4.2 Fan supply

Some power feedback units are equipped with two terminals (blue terminal = neutral [N] , grey fuse terminal = phase [L]) for the supply of the internal fan(s). The fuse inside the fuse terminal is installed for internal wire protection and of the following type **2A medium 500V 5x30mm**.

#### 4.4.3 Control wires

- Connect the control wires to the terminal row X2 at the control board of the power feedback unit.
- Don't parallel control wires to interfering power wires.
- Connect the screening of the control wires with an as big as possible surface to the metal cable glands of the flange.

#### 4.4.4 Control functions

The control terminal strip is placed on the control board and is indicated with X2. It is fitted with a plug-in device for easy handling (see figure 4.4.4.2).

The control board must always be designed for the respective main circuit voltage. Therefore the main circuit voltage (230 V, 380 V - 415 V, 440 V - 480 V, 500 V or 690 V) must be declared with every order. This is also necessary for a possible exchange of the device.

From the control terminal strip the operating condition or rather the collective error can be connected to extern. There is also the possibility to execute the external reset or the switch-functions and to connect them with the controller or the PLC.

# Installation

## Space diagram of the control board REV 1.4.X

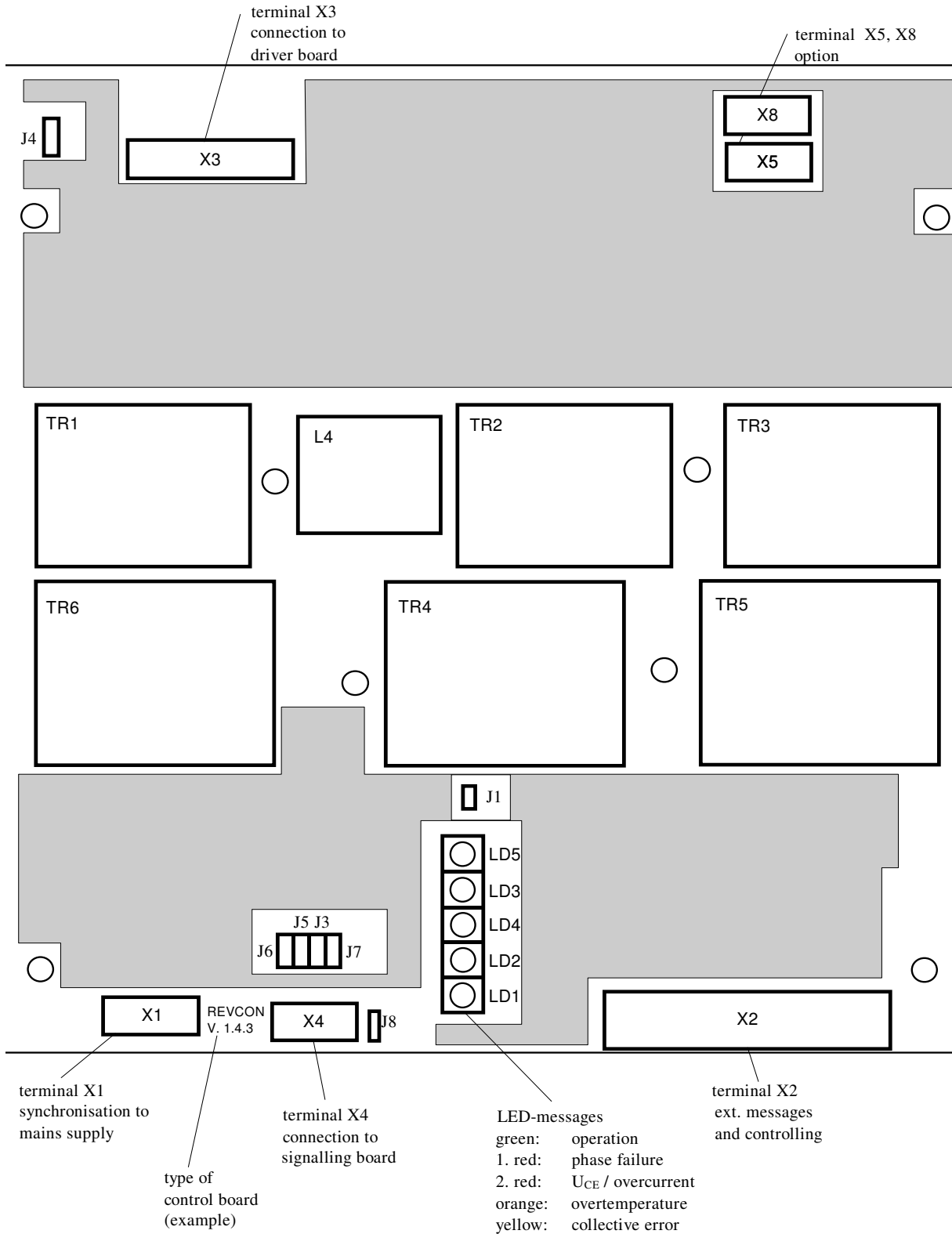

Figure 4.4.4.1

**Terminal usage:**

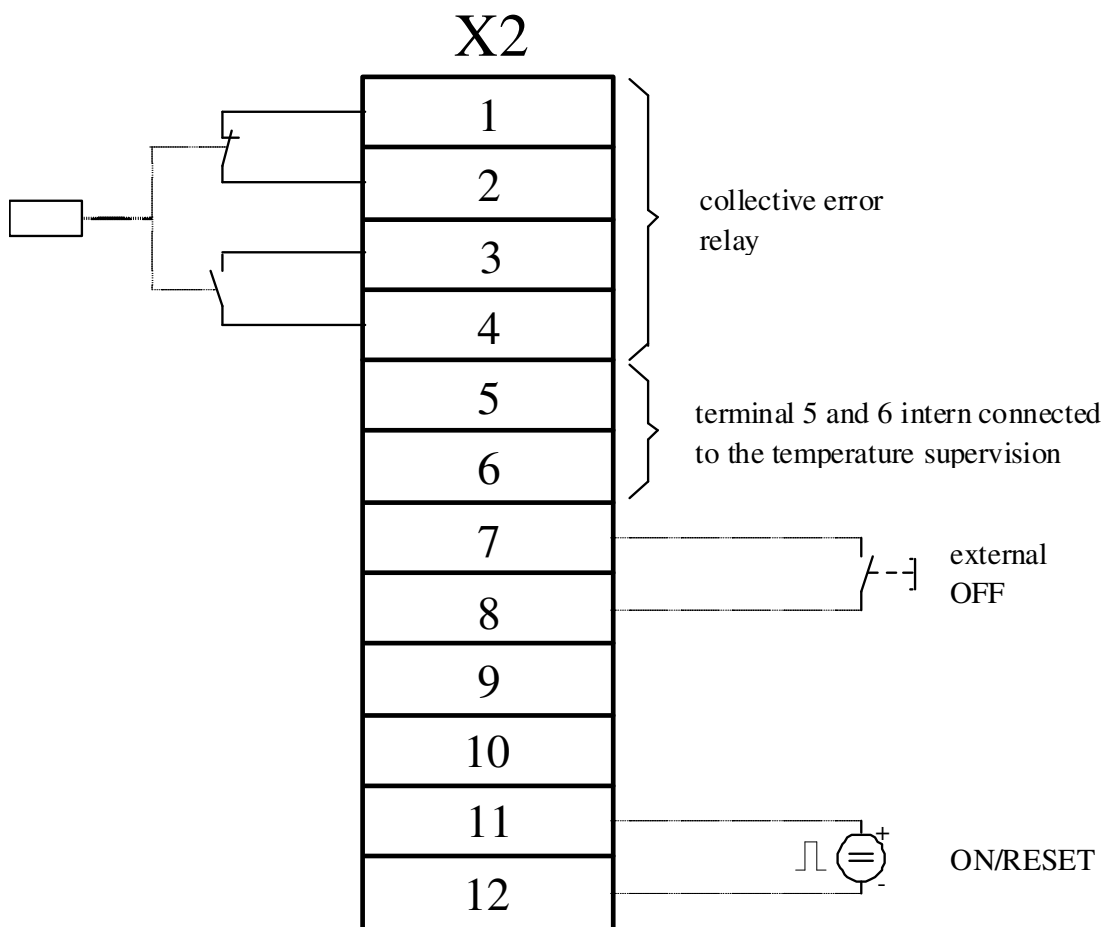

Figure 4.4.4.2

**Terminals 1-4 (refer to figure 4.4.4.2)**

These terminals are contacted to two potential free (SELV) relay contacts (one NOC and one NCC) with a maximum current load of 5 A AC or 3 A DC. It is not allowed to connect other voltage types than SELV!

In figure 4.4.4.2 the relay is displayed in rest position.

The relay toggles, if:

- 1.) power supply is o.k.,
  - 2.) no error present,
- and after perhaps an ON-signal has been released.

If an OFF-signal has been released, an collective error is display as the relay toggles.

## Installation

### **Terminals 5 and 6**

These terminals are already used for the internal temperature supervision of the heat sink.

### **Terminals 7 and 8**

#### **(use screened wires only, max length)**

#### **OFF-signal**

These terminals may be used for an external **OFF**-signal (NOC, short time contact) to stop the power feedback unit.

---

#### **Note!**

**F**

The OFF-signal stops the backfeeding immediately. If this is done in regen mode, the controller would trip because of too high DC-bus voltage right afterwards.

---

### **Terminal 11 and 12**

#### **(used screened wires only)**

These terminals may be used for an external **ON**-signal (external voltage 12 – 24V DC [e.g. from PLC], short time pulse) to start / reset the power feedback unit.

(connect „Plus“ to terminal 11, „Minus“ to terminal 12)

## 4.5 Application example

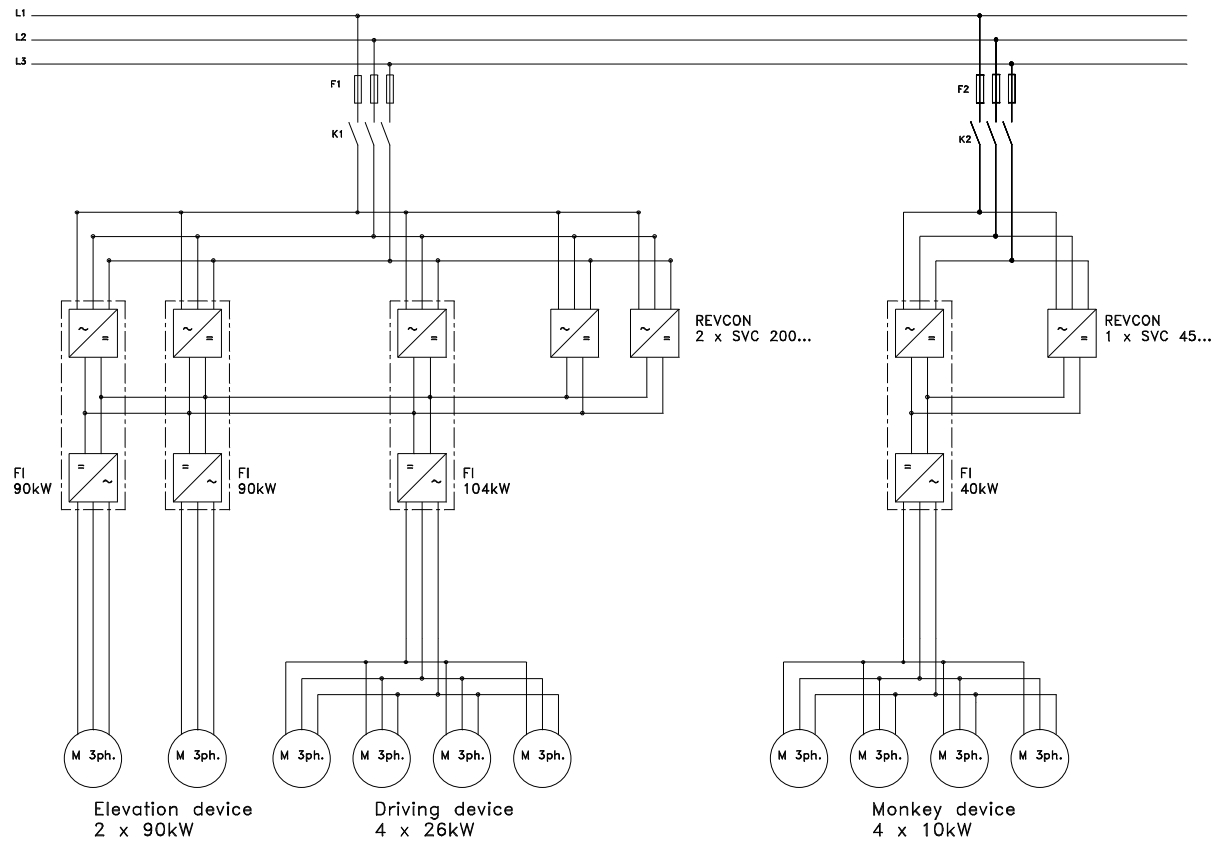

figure 4.5.1

Within greater plants several power feedback units may be coupled. Figure 4.5.1 shows an example of a windage plant with some possible combinations. The operation of several inverters at one common DC-bus allows to reduce the amount of power feedback units. On the other hand several power feedback units may be coupled to transmit more power. It's also possible to drive several motors at one inverter, as they react, seen from the DC-bus (and that's, what the power feedback unit sees), like one big motor.

To proportion such a plant it is important to look at the worst case. The maximum feedback power of the power feedback unit has to be higher as or , at a minimum, equal to the total amount of the braking power of the connected motors.

## Installation

### 4.6 Installation of a power feedback unit in a CE-typical drive system

<b>General</b>	<ul style="list-style-type: none"><li>• <b>The user is responsible for the compliance of his application with the EC directives.</b><ul style="list-style-type: none"><li>- If you observe the following measure you can be sure that the drive system will not cause any power-feedback-unit-caused EMC problems, i.e. comply with the EMC Directive when running the machine.</li><li>- If devices which do not comply with the CE requirement concerning noise immunity EN 500082-2 are operated close to the power feedback unit, these devices may be interfered electromagnetically by the power feedback units.</li></ul></li></ul>
<b>Assembly</b>	<ul style="list-style-type: none"><li>• Connect the power feedback unit and the RFI-filter to the grounded mounting plate with a wire of large cross section as possible:<ul style="list-style-type: none"><li>- Mounting plates with conductive surfaces (zinc-coated or stainless steel) allow permanent contact.</li><li>- Varnished boards should not be used for installation in accordance with EMC.</li></ul></li><li>• If you use several mounting plates:<ul style="list-style-type: none"><li>- Connect as much surface of the mounting plates as possible (e.g. with copper bands)</li></ul></li><li>• Ensure the separation of power and control cables.</li><li>• Cable guides as close as possible to the reference potential. Unguided cables have the same effect as aerials.</li></ul>
<b>Filters</b>	<ul style="list-style-type: none"><li>• Use RFI filters which are assigned to the power feedback unit. RFI filters reduce impermissible high frequency interference to a permissible value.</li></ul>
<b>Screening</b>	<ul style="list-style-type: none"><li>• Metallic cable glands ensure a big-surface connection between screen and housing</li><li>• If the screened wire are interrupted at relays or terminals:<ul style="list-style-type: none"><li>- Connect the screens of the wires with a big surface to the mounting plate.</li></ul></li><li>• If the mains wires between RFI-filter and power feedback unit are longer than 300mm:<ul style="list-style-type: none"><li>- Use screened mains wires</li><li>- Connect the screen direct at the controller / power feedback unit and at the RFI-filter to the mounting plate.</li></ul></li><li>• Screen the control wires:<ul style="list-style-type: none"><li>- Connect the screens on the shortest possible way to their terminals.</li></ul></li></ul>
<b>Earthing</b>	<ul style="list-style-type: none"><li>• All metallic conduction components (power feedback unit, controller, RFI-filter) have to be connected to one common earthing point (PE-bus bar).</li><li>• Observe the in the safety guidelines defined minimum cross sections:<ul style="list-style-type: none"><li>- For EMC not the cross section, but the surface of a wire and the contact to the mounting plate is important for the function.</li></ul></li></ul>

Power feedback units are electrical units for usage in industrial and commercial plants. In accordance with the EMC guideline 89/336/EEC it is not obligate to mark these units, as in the sense of the EMC guideline and the EMC law they are components to be mounted by an competent electromechanical engineer and cannot be used stand alone. The proof of the observance of the protective aims of the EMC guideline has to be carried out by the erector / user of the machine / plant. If the by ELTROPLAN-REVCON released RFI-filters are used and the following measures and installation guidelines are observed, the adherence to the prescribed data is cleared.

In combination with the related RFI-filter the power feedback unit has been designed for the usage in ambients of the limit class „A“ („B“ on request).

Definition in accordance with basic standard:

- EN50081-2 for emission
- EN50082-2 for immision

### 4.6.1 Installation

#### **Appropriate design of pant and cabinet.**

To avoid noise incoupling lay

- a) mains/supply wires
  - b) motor wires of controllers / servo amplifiers
  - c) control- and data wires (small voltage range < 48 V)
- with a distance of at least 15 cm between each other.

To obtain low resistive HF-connections, grounding, screening and other metallic connections (e. g. mounting plates, mounted units) have to be done with a as big as possible surface to metallic ground. Use grounding and potential equalisation wires with as big cross section as possible (min. 10mm<sup>2</sup>) or thick grounding tapes.

## Installation

Use copper or tinned copper screened wires only, as steel screened wires are not suitable for high frequency applications. Connect the screen with metal clamps or metal glands to the equalisation bars or PE-connections. Don't elonger the screen with single wires!

If external RFI-filters are use, these have to be mounted not more than 30cm away from the noise source and with a very good, low resistive based contact.

Inductive switching units (relay, magnetic contactor and so on) have to be equipped with varistors, RC-circuits or suppressor diodes always.

All connections have to be as short as possible and must lay as close to the ground potential as possible, as free hovering wires act like aerials.

Avoid wire loops in all wires. Connect unused wires to ground at both ends.

If unscreened wires are used, intertwist the pairs to attenuate unsymmetrical noise.

### 4.6.2 Connection of a RFI-filter

The following figure shows mounting and connection of an external RFI-filter.

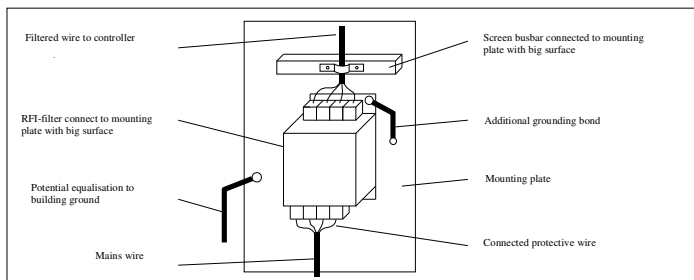

### 4.6.3 Design of an EMC-conformal cabinet

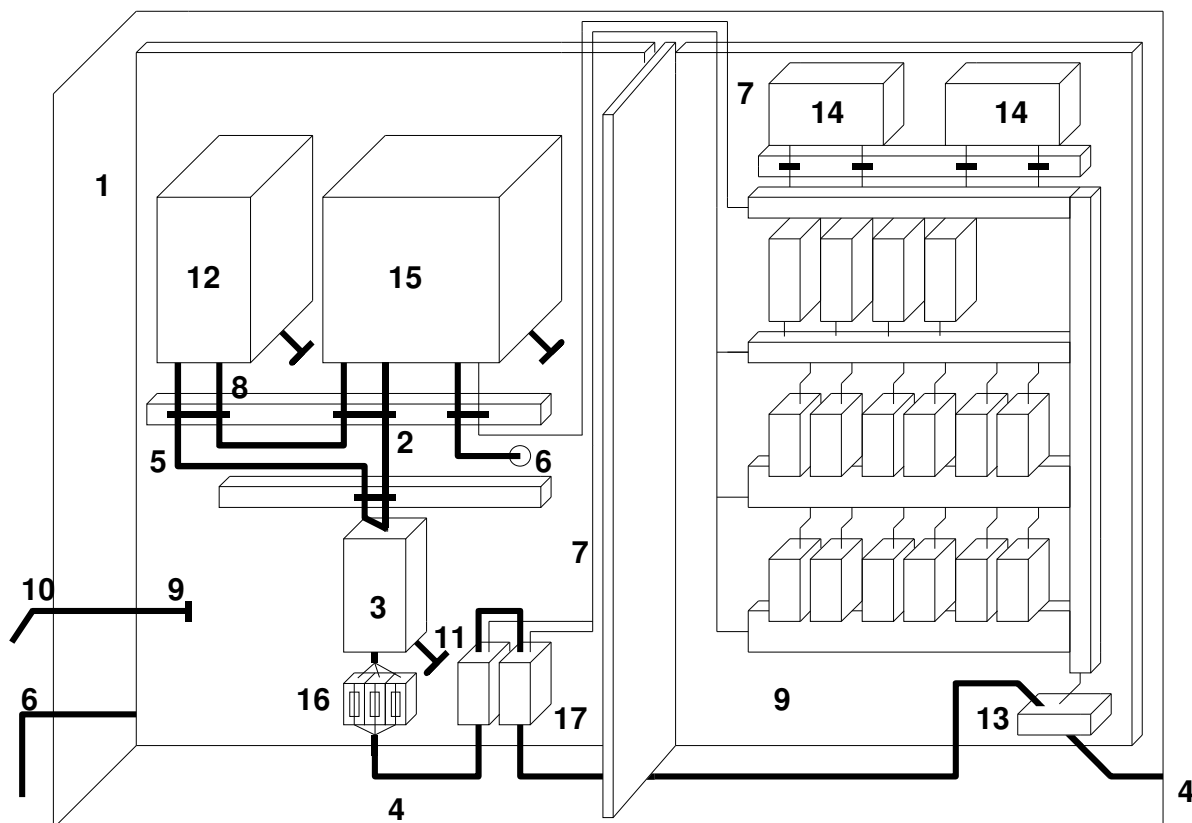

- |   |   |
|---|---|
| <ol style="list-style-type: none"> <li>1. Cabinet</li> <li>2. Wiring between RFI-filter and controller</li> <li>3. RFI-filter</li> <li>4. mains supply wire</li> <li>5. Wiring between RFI-filter and power feedback unit: cross section in accordance with fusing or short circuit proof!</li> <li>6. motor wiring</li> <li>7. control wiring</li> </ol> | <ol style="list-style-type: none"> <li>8. DC-bus wiring with power feedback unit (DC)</li> <li>9. Mounting plate (common star point)</li> <li>10. Potential equalisation</li> <li>11. additional earthing wire</li> <li>12. power feedback unit</li> <li>13. mains connection</li> <li>14. PLC</li> <li>15. Controller</li> <li>16. mains fuses</li> <li>17. mains magnetic switch</li> </ol> |
|---|---|

### 4.6.4 Remarks

Generally a system should be divided in an area for power electronics and an area for control electronics. This is not only important, if the system is mounted in one cabinet, but even also if it is spread over several cabinets. As of the strong noise emission of the power wires it is recommended to mount a screening wall. This wall must have a low resistive contact to the frame or the mounting plate (remove lacquer!).

The installed power feedback unit and the connected RFI-filter must form an integrated whole, i.e. they have to be connected via the mounting plate without an isolating lacquer.

The connection wire between power feedback unit and RFI-filter must be screened. At both ends the screen has to be connected to ground. The wire should not be longer than 300mm.

The mounting plate of the power feedback unit should be the star point for the whole grounding and screening of the machine or plant. If the drive or other components of the plant cause interference, the HF connection of these components is bad. This could be improved by an additional potential equalisation.

By using RFI-filters the leakage current is increased. As the leakage current is higher than 3,5 mA, one of the following conditions must be fulfilled:

- Cross section of the protective wire must be at least 10 mm<sup>2</sup> CU.
- Supervision of the protective wire by an module, which trips in case of an fault.
- Install a second wire in parallel to the protective wire via separate terminals. This wire must be conformal with VDE 0100 / part 540.

#### **4.6.5 Installation of control wires**

The screen of digital signal wires, which are not connected to terminals, has to be connected to the screen bars to decrease the impedance of the screen.

The screen of digital signal wires, which are connected to terminals, has to be connected with as big surface as possible to ground.

If the screen is grounded via a single wire, the noise discharge is getting worse by 70%.

For screen connection commercial cable clamps are suitable.

If unscreened signal wires are used, install only twisted pair wires.

### 5 Commissioning



---

**Stop!**

Prior to initial switch-on of the power feedback unit check the wiring for completeness, short-circuit and earth fault.

---



---

**Stop!**

If the wiring is not correct, a non-intended operation of controller and/or power feedback unit is possible.

---

#### 5.1 First powering up

1. Switch on mains supply :
  - The power feedback unit is ready for operation after ca. 1s
2. Check the readiness for service of the power feedback unit:
  - If only the green LED is on:
    - power feedback unit is ready for service.
  - If beside the green LED also other LED's are on:
    - A disturbance is present. Before proceeding with commissioning, remove the disturbance (refer to chapter 7 "Troubleshooting").
3. Check the readiness for service of the controller:
  - Proceed in accordance with the controller manual.

## 6 Configuration

The coding of the jumpers enables different driving possibilities and different internal functions in accordance to specific error messages.

In the following different definitions are explained which result from the specific possibilities of coding!

### a) „Autostart“

Autostart means that the device is starting with a delay-time of about 1 sec. after connecting mains voltage automatically ("automatically switch-on").

Coding via jumper, see figure 4.4.4.1:

J1 closed : Autostart

If the unit should not start automatically despite the phase failure control is disabled, during the switch on process the terminals 7 and 8 have to be bridged till 4 s after switching on. To start the backfeeding afterwards a short impulse has to be given on the RESET input.

### b) „Switch on“ - „Switch off“

„Switch off“ means that the driving of the semiconductors and the power feedback will be interrupted. A braking operation of the frequency inverter with power feedback is no longer possible.

„Switch-on“ is the activation of driving the semiconductors.

### c) „Storage“

The unit is equipped with an error storage where special failures can be assigned to. Stored error messages have to be confirmed by RESET or interruption of mains supply. "Storage" always leads to a "switch-off" and to a collective-error-relay tripping.

## Configuration

### d) Reset

After the failure is removed, a stored error has to be reset by pushing the RESET-button or rather by switching-off and on again the main circuit voltage (3-ph.)



### Stop!

**A reset in case of too high DC-bus voltage during the braking operation is not recommend. If it is done nevertheless, the power semiconductors are exposed to increased stress, which may lead to accelerated aging.**

### e) „Phase failure“

The phase-failure-supervision monitors the mains supply in all 3 phases.

In case of a breakdown of one phase the unit stays still in function, but with reduced feedback power.

The power feedback unit reacts in different ways on phase failures. One possibility is the "2 phase operation", the other one let the system get out of operation and the collective-error-relay signals the failure.

Coding via jumper, see figure 4.4.4.1.1:

J3	J5	J6	J7	phase-failure-supervision		
—	0	0	—	sensitive, error storage "ON"	0	Jumper open
—	—	—	—	insensitive, error storage "ON"	—	Jumper closed
0	X	X	—	off, but error storage "ON"	X	Jumper random
0	X	X	0	off, error storage "OFF"		

Remark: Jumper J7 is only existing from version 1.4.2 of the control board. Error storage "ON" means that the error "phase failure" is shown via LED until you confirm. Error storage "OFF" how-ever means that the error "phase failure" is shown via LED only as long as the failure is really existing.



**STOP!**

Pull off the jumper J3 is only allowed by interrupting the pulses of the frequency inverter or of the power feedback unit in the case of switching off the mains by series interrupting devices like contactors, main switches or any others. This is necessary to stop the power feedback to prevent a dangerous voltage rise on devices in the sector where the power is switched-off. The Jumper J7 should only be removed in the case of Jumper J3 is removed. Otherwise when the phase-failure-supervision is active a "phase failure" will only be shown as long as the failure is existing (no error storage).

**f) Overvoltage supervision**

Since the control board version 1.4.3 the device has an overvoltage supervision for the mains which switches off the device in the case of a voltage level of approximately  $1,15 \times U_N$  and above. As an error message the error code 3 will be shown (see chapter 7.1). For the differentiation of the error messages phase failure and overvoltage you have the possibility to deactivate the phase-failure-supervision by removing the jumper J3 on the control board. If after that a switch-off with the indication via the red and yellow LED (error code 3) happens, an overvoltage will be the reason of the switch-off then.

J3	J5	J6	J7	J8	LED Message			evaluation (overvoltage)
—	X	X	—	—	Green	1.red	yellow	overvoltage a/o phase failure/commutation error
—	X	X	0	—	green	—	yellow	overvoltage
0	X	X	—	—	green	1.red	yellow	overvoltage a/o phase failure/commutation error
0	X	X	0	—	green	—	yellow	overvoltage
0	X	X	0	—	green	1.red	yellow	constant phase failure

**Remark:**

- 0 Jumper open
- Jumper closed
- X Jumper random

**Standard adjustment of the device**

Autostart and no switching off in case of phase failure

### 7 Troubleshooting and fault elimination

The four LED's in the cover of the power feedback unit display the operating condition. For easier visibility during service and first powering up similar LED's are placed on the control board. Unlike to the cover on the control board there are separate orange and green LED's, whose function in the cover are served by a bicolour (green/orange) LED.



---

#### **Stop:**

If the power feedback unit trips during a retardation, it must not be reset until the end of the retardation and until the DC-bus voltage has fallen to normal values.

To avoid any kind of problems you can block the impulse-release of the inverter by connecting the collective-error-relay-contact of the power-feedback-unit with the corresponding connection of the frequency inverter.

---

#### **U<sub>CE</sub>-tripping:**

The power feedback unit trips by the U<sub>CE</sub>-protective-circuitry, if the specific maximum current of the device is exceeded. The principle of this protective-circuitry implies that for a short time (less than one millisecond) the IGBT is stressed over its specification for normal operation. For an single case this means no problem for the power feedback unit. However, if the over current cut off arises often or even periodically, the high power semiconductors will age very rapidly and fail premature.

The cause of periodical U<sub>CE</sub> cut offs may be over load, under voltage in the network, a defective or oscillating controller, an oscillating reference input or a wrong design of the plant.

## 7.1 LED-messages

LED-Display Error code:	LED - display					Evaluation	
	operation	phase-failure	U <sub>CE</sub>	over-temp.	error	At first starting	During operation
	green	red	red	orange	yellow		
1	X					Ready to operate (after approx. 1s)	System in operation
2	X					Ready for operation, but no power feedback ⇒ check the DC-fuses	
3	X*			X*	X		overtemperature of the heat sink ⇒ error-message is not resettable as long as the temperature is too high
4	X				X		Error code 3 ⇒ heat sink temperature declined to normal and the error is resettable.
5	X				X	System has been switched off, (external OFF) ⇒ reset necessary	System has been switched off, (external OFF) ⇒ reset necessary
6	X				X	Overvoltage has been detected (J8 closed) ⇒ after grid voltage has declined to its nominal value, reset necessary	
7	X	X			X	Rotary field orientation incorrect or one phase is missing	Phase failure has been detected ⇒ reset necessary
8	X		X		X		Overcurrent has been detected ⇒ reset necessary
9	X	X	X		X	error code 7 and 8	Overcurrent and phase failure have been detected simultaneously .
10	X*	X	X	X*	X	Several errors have been detected simultaneously	Several errors have been detected simultaneously
11						System off, at least two phases lost	System off, at least two phases lost
12	X				X		With option IFP: I <sub>Pt</sub> -tripping ⇒ reset necessary
13	X	X					Voltage breakdown during commutation but without tripping as jumper 3 and 7 are open (chapter 6e) ⇒ operation possible, mains supply improvement recommended

Table 7.1.1

### 8 Service

The power feedback unit is maintenance-free, if the provided application conditions are observed (refer to chapter 3.2).

If the cooling air is polluted, the cooling air input may be blocked. Therefore check the power feedback unit periodically (depending on the degree of pollution approx. every 4 weeks).



---

#### **Stop!**

Don't use sharp or tapering objects like knife or screw driver to clean the cooling air input.

---

Clean the cooling air input with a vacuum cleaner.

## 9 Appendix

### 9.1 Options

#### 1. Fuse holder with fuses for mains supply

In accordance with table 3.3.3.1.1-5 for the power feedback unit the following fuses are available:

<i>REVCON</i> <sup>®</sup> - type	Order designation	Case type
SVC(S) 7 to SVC(S) 135	SH SVC(S) ZZZ-XXX	A
SVC(S) 140 to SVC(S) 200	SH SVC(S) ZZZ-XXX	B

ZZZ  $\cong$  rated power of the power feedback unit

XXX  $\cong$  rated voltage of the power feedback unit

#### 2. Option IL (Isolating lacquer)

To protect the electronic components of the power feedback unit from pollution of the cooling air, all printed circuit boards may be coated with an isolating lacquer. This option improves the service reliability, but it doesn't release the user from the duty to observe the in chapter 3.2 specified application conditions.

#### 3. Overvoltage-suppressor

If the power feedback unit (as well as a controller) is connected to ungrounded mains supply, it only may be run, either if it is connected via an isolating transformer or if the plant is protected by overvoltage suppressors. But also with grounded mains supply it may be useful to install overvoltage suppressors, if it is possible, that voltage peaks occur. For choosing the best overvoltage suppressor for your specific application, please get in contact with one of our technicians.

#### 4. RFI-filter

For technical data concerning the RFI-filter refer to chapter 3.3.4 (type overview), 4.2.2 (dimensions) and 4.6.2 (connection).

### 5. External operating and signalling panel

When mounting the device inside a cabinet it is possible to mount an operator panel in the door of the cabinet by using the external operating and signalling panel. The external operating and signalling panel contains the complete display (LED's) of all running and failure messages of the power feedback unit and also the ON / RESET push button switch.

The connection to the power feedback unit has to be done with a (shielded) flat cable to the socket X4 of the control board (refer to figure 4.4.4.1).

---

#### Note:



The connection of the external operating and signalling panel to the power feedback unit has no influence on the operating and error messages of the LED's placed on the control board. In this case both displays are active on the same time.

In case of simultaneous usage of the external operating and signalling panel and the ON/OFF function via the control terminal X2 the switch off signal always has priority, independent of the ON-RESTE push button switch.



---

#### Stop:

Don't put an external voltage to the socket X4 of the control board or to the external operating and signalling panel. This may damage the device.

---

## 9.2 REVCON Product overview

1. **REVCON SVC(S)**  
Power feedback unit for short time operation  
(Crane plants, discontinuous centrifuges, etc.)
2. **REVCON SVC(S)D**  
Power feedback unit for continuous backfeed operation  
(Motor test plants, automatic staircases, wind power plants, lifts, etc.)
3. **REVCON DCV**  
Power feed and feedback unit  
For multiple motor applications with dynamic load changes [4Q]
4. **REVCON OSKM**  
Harmonic current compensation module  
(for reducing the harmonic load of electrical power supply networks)
5. **REVCON PFU**  
Power feedback unit for regenerative power plants. In combination with a permanent excited generator no controller is necessary! (wind-/water power plants etc.)
6. **REVCON HSTV**  
Boost chopper for generating an increased DC-bus voltage, which enables the controller to drive the motor with full torque and increased speed
7. **REVCON EDC**  
Power feed module for multiple controller without generatory mode
8. **REVCON SKS**  
Filter module for generating of sinewave mains currents (THD I 8-15% depending on controller and load). May connected to REVCON SVC(S), SVC(S)D, DCV, CDCV and PFU and to the most commercial controllers!

All products are available for 400V mains voltage, most of them as well for 230V, 460V, 500V and 690V! Depending on the product power from 4 up to 200kW may be transmitted. Most of the products may be connected in parallel, so that a power up to 1MW is possible!

### 9.3 Contact

**Eltroplan-REVCON Elektrotechnische Anlagen GmbH**  
**Edisonstraße. 3**  
**D-59199 Bönen**

**Phone**           **+49 (0)2383 920 22 22**

**Fax**               **+49 (0)2383 920 22 66**

**E-Mail**           **[info@REVCON.de](mailto:info@REVCON.de)**

**Web**               **[www.REVCON.de](http://www.REVCON.de)**

**< SUBJECT TO CHANGE WITHOUT NOTICE >**

03/10

<b>A</b>		<b>O</b>	
<b>application conditions</b> .....	28	operating and signalling board, external .....	68
<b>C</b>		<b>operator's safety</b> .....	16, 43
cable glands .....	54	overvoltage suppressor .....	67
<b>CE-mark</b> .....	6	<b>P</b>	
compensation plants .....	12, 26	patents rights .....	5
<b>connection</b> .....	45, 46	personnel	
<b>contact</b> .....	70	qualified .....	10
<b>control functions</b> .....	49	<b>power feedback unit</b> .....	3
<b>controller</b> .....	3, 12	<b>product overview</b> .....	69
cooling air .....	37	<b>protection of the device</b> .....	16
<b>current load</b> .....	30, 51	<b>Q</b>	
<b>D</b>		<b>qualified personnel</b> .....	15
<b>dimensions</b> .....	38	<b>R</b>	
<b>drive system</b> .....	3, 11, 15	<b>rated data</b> .....	29
<b>CE-typical</b> .....	54	readiness for service .....	60
drive systems .....	5	<b>RFI-filter</b> .....	36, 41
<b>E</b>		<b>S</b>	
EC-Directives .....	5	<b>safety information</b> .....	10, 11, 16
Efficiency .....	29	screening .....	49, 54
ESDS .....	43	<b>service</b> .....	66
<b>F</b>		<b>SKS-module</b> .....	36
<b>fan supply</b> .....	49	standards .....	7, 45, 46
<b>filtering</b> .....	54	<b>T</b>	
free spaces .....	37	terminal usage .....	51
fuses		transport .....	10, 28
serial .....	67	transport damage .....	4
<b>G</b>		troubleshooting .....	60, 64
generator .....	12, 19	<b>type determinator</b> .....	4
<b>I</b>		<b>U</b>	
Icons .....	16	UL .....	44, 45
isolating lacquer .....	67	user .....	15
<b>L</b>		<b>V</b>	
low-voltage directive .....	6, 10, 28	voltage, external .....	68
<b>M</b>		<b>W</b>	
machinery guideline .....	8	<b>warranty</b> .....	5, 12
Mains frequency .....	29	wires	
mains terminals .....	34	screened .....	44
<b>mains types</b> .....	44	<b>wiring schematic</b> .....	47
mounting position .....	37		