

REV.	CNN	CNN DESCRIPTION	Date	Check in
01	-	-	01/03/2011	John Hutchinson
03	-	-	07/03/2011	John Hutchinson

LINE

LOAD

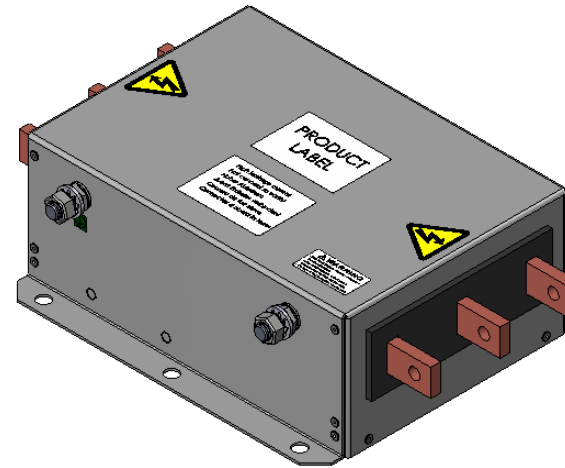
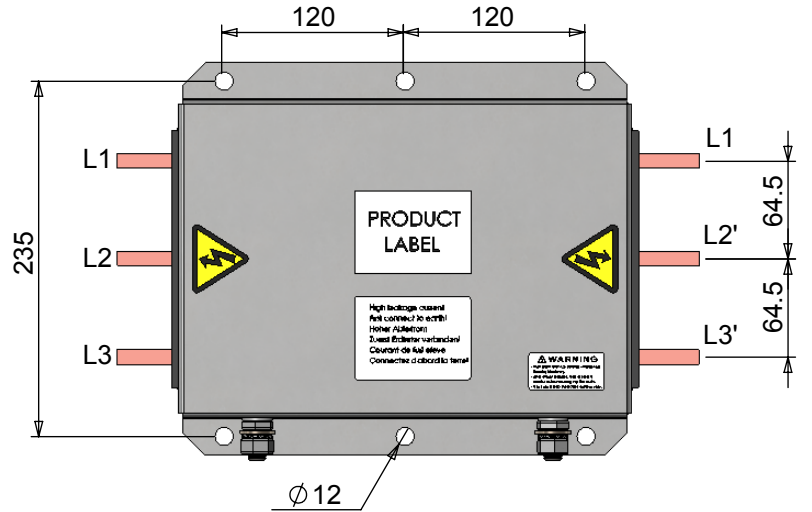

ELECTRICAL
3P RFI Filter

current 620A (50°C)
voltage 480V (+10%)

leakage fault 85mA
leakage normal <5mA
operating frequency 50/60Hz
residual voltage (245V 10s, 1.6V 60s)
resistance dc 0.034mR (50°C)
short circuit 42kA (200kA)
voltage withstand 3.3kVdc 1s
watts loss 39W (50°C)

MECHANICAL

busbar holes M10. 30Nm
earth stud M12. 25Nm
fixing holes M10. 30Nm
mass unpackaged 15.0kg
material enclosure Al
material busbars Cu
material fixings SS

ENVIRONMENT

humidity 90% RH (non-condensing)
pollution class II
temperature -25 to +90°C
vibration 5-500Hz 1.5G

STANDARDS

EN60939-1 / EN61010-1
EN60950 / EN50178
UL1283 / UL508C / CSA C22.2 No.8

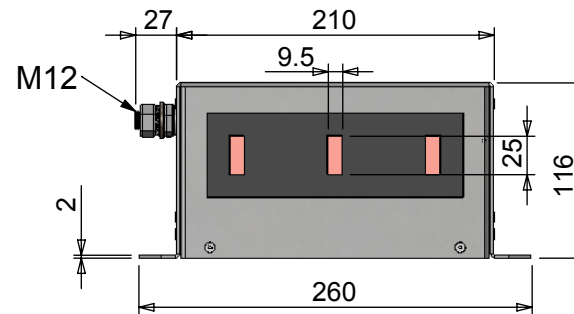
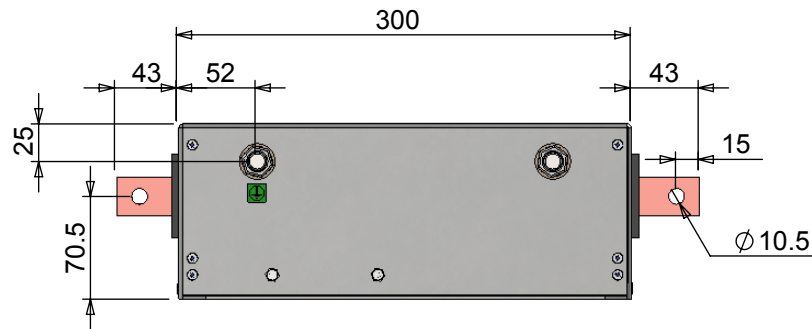

Tel No. +44(0)1724 273200 Website www.dem-uk.com



PROPRIETARY AND CONFIDENTIAL
THE INFORMATION CONTAINED IN THIS DRAWING IS THE SOLE PROPERTY OF ALPHA 3 MANUFACTURING.
ANY REPRODUCTION IN PART OR AS A WHOLE WITHOUT THE WRITTEN PERMISSION OF ALPHA 3 MANUFACTURING IS PROHIBITED.
DEM DEM Manufacturing, Deltron Emcon House
Hargreaves Way, Sawcliffe Ind. Park,
Scunthorpe, North Lincolnshire, DN15 8RF, UK

UNLESS OTHERWISE SPECIFIED:
DIMENSIONS ARE IN MILLIMETRES
LINEAR TOLERANCE:
NO DECIMAL PLACES ±0.5mm
1 DECIMAL PLACE ±0.25mm
2 DECIMAL PLACES ±0.125mm
ANGULAR TOLERANCE: ±1°

FINISH	-	DEBURR AND BREAK SHARP EDGES
MATERIAL	1.2mm ALU	

DRAWN BY	SPB
APPROVED BY	SW
THIRD ANGLE PROJECTION	
SHEET 1 OF 1	
SCALE 1:5	
A4	

TITLE	General Specification	
	KMF3620A	
	Mains Line Filter	
DRAWING NO.	KMF3620A	ISSUE 03
		Release